

Draft e-Tender Document

FOR

**Systematic Cleaning of Sewers of sizes 600mm and below in Eastern Suburb
Area.**

Tender ID : 2026_MCGM_1307394

Website: <https://mahatenders.gov.in>

Office of:-

**Deputy Chief Engineer (S.O.) Planning & Construction,
1st Floor, S.O. Administrative Building,
249, Senapati Bapat Marg,
Dadar (West), Mumbai – 400 028.**

Prepared By

Checked By

Approved By

Sd/-
01.06.2026
A.E.(S.O.)P&C

Sd/-
03.06.2026
E.E.(S.O.)P&C

Sd/-
04.06.2026
Dy.Ch.E.(S.O.)P&C

Sd/-
08.06.2026
Ch.E.(S.O.)

INDEX

SECTION	DESCRIPTION	PAGE NO.
1	E-TENDER NOTICE	3-7
2	ELIGIBILITY CRITERIA	8-11
3	DISCLAIMER	12-14
4	INTRODUCTION	15-16
5	E-TENDER ONLINE SUBMISSION PROCESS	17-21
6	INSTRUCTIONS TO APPLICANTS	22-46
7	SCOPE OF WORK	47-49
8	BILL OF QUANTITIES	50-52
9	GENERAL CONDITIONS OF CONTRACT	53-116
10	SPECIAL CONDITIONS OF CONTRACT	117-119
11	SPECIFICATIONS	120-188
12	FRAUD AND CORRUPT PRACTICES	189-192
13	PRE-BID MEETING	193-194
14	LIST OF APPROVED BANKS	195-198
15	APPENDIX	199-261
16	DRAWING	262-267

SECTION 1

E-TENDER NOTICE

BRIHANMUMBAI MUNICIPAL CORPORATION

(Sewerage Operations Department)

Tender ID: 2026_MCGM_1307394

E-TENDER NOTICE

Subject: Systematic Cleaning of Sewers of sizes 600mm and below in Eastern Suburb Area.

The Brihanmumbai Municipal Corporation (BMC) invites e-tender on percentage rate basis to appoint Contractor for the aforementioned work from contractors of repute, multidisciplinary engineering organizations i.e. eminent firm, Proprietary/Partnership Firms / Private Limited Companies / Public Limited Companies / Companies registered under the Indian Companies Act 2013, the contractors registered with the Brihanmumbai Municipal Corporation, (BMC) in Class AA as per old registration and Class A as per new registration. And from the contractors / firms equivalent and superior classes registered in Central or State Government / Semi Govt. Organization / Central or State Public Sector Undertakings, will be allowed subject to condition that, the contractors who are not registered with BMC will have to apply for registering their firm within three months time period from the award of contract, otherwise their Bid Security i.e. E.M.D (Earnest Money Deposit) will be forfeited / recovered and an amount equal to Registration Fee of respective class will be recovered as penalty.

Bidding Process will comprise of THREE stages.

The application can be downloaded from e-procurement system of Government of Maharashtra Mahatenders portal (<https://mahatenders.gov.in>). Bidder shall pay Tender fee of Rs.19,965/- + 18%GST mentioned in header data as per circular no. CA/FRG/15 dt.20.03.2026 and CA/FRG/09 dt.04.10.2024 annexed in the Tender Document. The applicants not registered with BMC are mandated to get registered (Vendor Registration) with BMC for e-tendering process also with Mahatenders & obtain login credentials to participate in the online bidding process.

i) To download the application form, for those applicants not having vendor registration, need to apply first for vendor registration at the office of Account Officer (FAR), 4th floor, Municipal Headquarter.

ii) Followed by Mahatenders login ID and password to be obtained from Mahatender portal <https://mahatenders.gov.in>

iii) For e-Tendering registration, enrollment for digital signature certificates and user manual, please refer to respective links provided in Mahatenders 'Tenders' tab such as <https://cca.gov.in> Vendors can get digital signature from any one of the Certifying Authorities (CA's) licensed by controller of certifying authorities namely, Safes crypt, IDRBT, National informatics center, TCS, CUSTOMS, MTNL, GNFC, e- Mudhra CA.

Name and location of work	Contract period	Estimated Cost of Project
Systematic Cleaning of Sewers of sizes 600mm and below in Eastern Suburb Area.	06 months Excluding monsoon)	Rs. 4,35,65,514.00

In terms of the 3-stage system of e-tendering, a Bidder will be required to deposit, along with its Bid, an **Earnest Money Deposit of Rs. 4,35,700/-** (Rupees **Four Lakh Thirty Five Thousand and Seven Hundred only**) (the "EMD"), refundable in accordance to the relevant clause of bid document, from the Bid Due Date, except in the case of the selected Bidder whose Bid Security/EMD shall be retained. The bidder shall pay entire amount of EMD through payment gateways of GoM on URL <https://mahatender.gov.in>. The bidders shall upload scan copy of online paid EMD along with the bid submission in packet 'A'. Any bid not accompanied by an acceptable Bid Security shall be rejected by the Employer as non-responsive.

As per THREE Packet systems, the document for Packet 'A' & 'B' is to be uploaded online by the bidder in Cover Type 'Fee/PreQual/Technical' and Price Packet 'C' is to be uploaded in Cover Type 'Finance'. Packet 'A', 'B' and 'C' shall be opened on dates as mentioned in header data. All the responsive and eligible bidders if they so wish can be present at the time of opening of bids, in the office of Deputy Chief Engineer (Sewerage Operations) Planning & Construction. The Price Packet 'C' (Cover Type 'Finance') shall be opened if bids submission in Packet 'A' & 'B' satisfies/includes all the requirements and same are found acceptable to the Authority.

The Municipal Commissioner reserves the right to reject all or any of the e- tender(s) without assigning any reasons at any stage.

The dates and time for submission and opening the bids are as shown in the Header Data. If there are any changes in the dates the same will be displayed on the e-procurement system of Government of Maharashtra Mahatenders portal (<https://mahatenders.gov.in>)

The Applicants interested for the above referred works may contact the office of Deputy Chief Engineer (Sewerage Operations) Planning & Construction at the following address on any working day during office hours.

Office of-
Deputy Chief Engineer (Sewerage Operations) Planning & Construction,
Sewerage Operation (S.O.) Administrative Building,
249, Senapati Bapat Marg, Dadar West,
Mumbai – 400 028.

The applicants may wish to visit the site/s under reference located at City and Eastern Suburb area, a part of Mumbai and can collect the information of the present status from the department who have invited the bids.

The BMC reserves the rights to accept any of the application or reject any or all the application received for above works, without assigning any reasons thereof. The information regarding above subject matter is available on e-procurement system of Government of Maharashtra (Mahatenders) (<https://mahatenders.gov.in>)

Bidders are also advised to refer “Bidders Manual Kit” available at eProcurement System Government of Maharashtra (<https://mahatenders.gov.in>) for further details about the e-tendering process. For any help, in the e-Tendering process, can be availed by dialing help-desk number 022-22046934/22837339 from 11.30 AM to 5.00 PM on all working days.
Email: support-eproc@nic.in

Interested bidders should follow the manuals available on Mahatenders Portal
<https://mahatenders.gov.in>.

Sd/-
(04.06.2026)
(Salil A. Garude)
Deputy Chief Engineer
(Sewerage Operations) Planning & Construction

HEADER DATA

Tender Document No	2026_MCGM_1307394
Name of Organization	BRIHANMUMBAI MUNICIPAL CORPORATION
Subject	Systematic Cleaning of Sewers of sizes 600mm and below in Eastern Suburb Area.
Estimated Cost	Rs. 4,35,65,514.00
Tender Fee	Rs. 19,965 + 18% GST.
Bid Security Deposit / EMD	Rs. 4,35,700/-
Date of issue and sale of tender	11/06/2026 from 11:00 Hrs
Last date & time for sale of tender & Receipt of Bid Security Deposit	01/07/2026 up to 12:00 Hrs
Submission of Packet A, B & Packet C (Online)	01/07/2026 up to 16:00 Hrs
Pre-Bid Meeting	18/06/2026 at 14:00 Hrs at S.O. Department, 2nd Floor Conference Hall, Engineering Hub Building, Dr. E'Mozes Marg, Worli, Mumbai – 400 018.
Opening of Packet A & B	03/07/2026 after 16:00 Hrs
Address for communication	Deputy Chief Engineer (Sewerage Operations) Planning & Construction, Sewerage Operation (S.O.) Administrative Building, 249, Senapati Bapat Marg, Dadar West, Mumbai – 400 028.
Venue for opening of bid	On line in Deputy Chief Engineer (Sewerage Operations) Planning & Construction's office.

This tender document is not transferable.

The BMC reserves the rights to accept any of the application or reject any or all the application received for above subject without assigning any reason thereof.

Sd/-
(04.06.2026)
Deputy Chief Engineer
(Sewerage Operations) Planning & Construction

SECTION 2

ELIGIBILITY CRITERIA

1. For Regular, Routine and Maintenance works:

1.1 Technical Capacity:

The tenderer(s) in their own name should have satisfactorily executed the work of similar nature in BMC /Semi Govt. /Govt. & Public Sector Organizations during last seven (7) years ending last day of month previous to the one in which bids are invited as a prime Contractor (or as a nominated sub-Contractor, where the subcontract had involved similar nature of work as described in the scope of works in this bid document, provided further that all other qualification criteria are satisfied)

(a) Three similar completed works of value not less than the value equal to **Rs. 87,13,103/-**

Or

(b) Two similar completed works of value not less than the value equal to **Rs. 1,08,91,379/-**

Or

(c) One similar completed works of value not less than the value equal to **Rs. 1,74,26,206/-**

And

The bidder shall have ownership of at least 02 nos. of High-Capacity Suction cum Jetting Machine / High-Capacity Super Sucker Machine with dump tank. Documentary proof of the same shall be uploaded along with the tender.

The value of executed works shall be brought to current costing level by enhancing the actual value of work at compound rate of 10 % per annum; calculated from the date of completion to last date of receipt of applications for tenders.

1.2 Financial Capacity:

Achieved an average annual financial turnover as certified by 'Chartered Accountant' equal to **Rs. 1,30,69,654/-** in last three (3) financial years immediately preceding the Financial Year in which bids are invited.

- To ascertain this, tenderer(s) shall furnish /upload the financial statement (Audited balance sheet) duly certified by Chartered Accountant.

- The turnover can be enhanced by 10% every year to bring the present level.

1.3 Similar Experience:

Similar work shall mean, the completed or ongoing works of "**Cleaning / De-silting of Sewer Lines / Storm Water Drains by use of Vehicle Mounted High-Capacity Suction and / or Jetting Machine or High-Capacity Super Sucker Machine along with CCTV survey**".

2. For Original and New construction works : (Not Applicable)

C. Bid Capacity: (Not Applicable)

The bid capacity of the prospective bidders will be calculated as under: Assessed Available Bid Capacity = $(A * N * 2 - B)$

Where,

A = Maximum value of Civil Engineering works executed in any one year (year means Financial year) during the last five years (updated to the price level of the Financial year in which bids are received at a rate of 10% per year) taking into account the completed as well as works in progress.

N = Number of years prescribed for completion of the Project/Works, excluding monsoon period, for which these bids are being invited. (E.g. 7 months = 7/12 year) For every intervening monsoon 0.33 shall be added to N.

B = Value of existing commitments (only allotted works) on the last date of submission of bids as per bidding document and on-going works to be completed during the period of completion of the Project/Works for which these bids are being invited.

Note: The statement showing the value of existing commitments and on-going works as well as the stipulated period of completion remaining for each of the works listed should be attached along with certificates duly signed by the Engineer-in-Charge, not below the rank of an Executive Engineer or equivalent.

Even though the bidders meet the above qualifying criteria, they are subject to be disqualified if they have:

- Made misleading or false representation in the forms, statements and attachments submitted in proof of the qualification requirements; and/or
- Record for poor performance such as abandoning the works, not properly completing the contract, inordinate delays in completion or financial failures etc.

SECTION 3

DISCLAIMER

DISCLAIMER

The information contained in this e-tender document or provided to Applicant(s), whether verbally or in documentary or any other form, by or on behalf of the Brihanmumbai Municipal Corporation (BMC), hereafter also referred as "The Authority", or any of its employees or advisors, is provided to Applicant(s) on the terms and conditions set out in this e-tender and such other terms and conditions subject to which such information is provided.

This e-tender includes statements, which reflect various assumptions and assessments arrived at by the Brihanmumbai Municipal Corporation (BMC) in relation to the Project. Such assumptions, assessments and statements do not purport to contain all the information that each Applicant may require. This e-tender may not be appropriate for all persons, and it is not possible for the Brihanmumbai Municipal Corporation (BMC), its employees or advisors to consider the investment objectives, financial situation and particular needs of each party who reads or uses this e-tender. The assumptions, assessments, statements and information contained in this e-tender may not be complete, accurate, adequate or correct. Each Applicant should therefore, conduct its own investigations and analysis and should check the accuracy, adequacy, correctness, reliability and completeness of the assumptions, assessments, statements and information contained in this e-tender and obtain independent advice from appropriate sources.

Information provided in this e-tender to the Applicant(s) is on a wide range of matters, some of which may depend upon interpretation of law. The information given is not intended to be an exhaustive account of statutory requirements and should not be regarded as a complete or authoritative statement of law. The Brihanmumbai Municipal Corporation (BMC) accepts no responsibility for the accuracy or otherwise for any interpretation or opinion on law expressed here.

The Brihanmumbai Municipal Corporation (BMC), its employees and advisors make no representation or warranty and shall have no liability to any person, including any applicant or Bidder, under any law, statute, rules or regulations or tort, principles of restitution or unjust enrichment or otherwise for any loss, damages, cost or expense which may arise from or be incurred or suffered on account of anything contained in this e-

tender or otherwise, including the accuracy, adequacy, correctness, completeness or reliability of the e-tender and any assessment, assumption, statement or information contained therein or deemed to form part of this e-tender or arising in any way with pre-qualification of Applicants for participation in the Bidding Process. The Brihanmumbai Municipal Corporation (BMC) also accepts no liability of any nature whether resulting from negligence or there wise howsoever caused arising from reliance of any Applicant upon the statements contained in this e-tender.

The Brihanmumbai Municipal Corporation (BMC) may, in its absolute discretion but without being under any obligation to do so, update, amend or supplement the information, assessment or assumptions contained in this e-tender.

The issue of this e-tender does not imply that the Brihanmumbai Municipal Corporation (BMC) is bound to select and short-list pre-qualified Applications for Bid Stage or to appoint the selected Bidder or Concessionaire, as the case may be, for the Project and the Brihanmumbai Municipal Corporation (BMC) reserves the right to reject all or any of the Applications or Bids without assigning any reasons whatsoever.

The Applicant shall bear all its costs associated with or relating to the preparation and submission of its Application including but not limited to preparation, copying, postage, delivery fees, expenses associated with any demonstrations or presentations which may be required by The Brihanmumbai Municipal Corporation (BMC) or any other costs incurred in connection with or relating to its Application. All such costs and expenses will remain with the Applicant and the Brihanmumbai Municipal Corporation (BMC) shall not be liable in any manner whatsoever for the same or for any other costs or other expenses incurred by an Applicant in preparation or submission of the Application, regardless of the conduct or outcome of the Bidding Process.

SECTION 4

INTRODUCTION

INTRODUCTION

1. Background:

The Municipal Corporation of Greater Mumbai covers an area of 437.71sq.kms.with a population of **1.24 Crores as per census of 2011**. The metropolis accounts major portion of India's international trade and government's revenue, from being one of the foremost centers of education, science and technological research and advancement.

The Mumbai Metropolis has historic tradition of strong civic activism dedicated to the cause of a better life for all its citizens. And it's the Brihanmumbai Municipal Corporation (BMC), hereafter called the "Corporation", the primary agency responsible for urban governance in Greater Mumbai.

BMC (The Authority) is one of the largest local self-governments in the Asian Continent. In observance of historic traditions of strong civic activism, with the change in time and living conditions to match with the urbanization, BMC has mainly focused in providing almost all kinds of engineering services viz, Hydraulics, storm water drain, sewerage, water supply projects, roads, bridges, solid waste management, and environmental services. Beside this, the BMC is also providing dedicated services in various segments such as Health, Primary Education as well as the construction and maintenance of Public Markets and Slaughter Houses.

BMC is an organization having different departments, right from engineering depts. to health depts. Moreover we have other dept. like education, market, fire brigade dept., Octroi and other such departments where quite a good number of staff members are working.

Scope of Work:

BMC is primarily an organization, which in the interest of citizens and with the speed of urbanization deals with the variety of the infrastructure services and delivered to the public by different departments like Water Supply Projects, Sewerage Projects, Hydraulics, Storm Water Drain/Roads and bridges and Building Construction etc.

(Scope of work is mentioned in Section 7)

SECTION 5

E-TENDERING ONLINE SUBMISSION PROCESS

E-TENDERING ONLINE SUBMISSION PROCESS

The terminology of e-Tendering is solely depending upon policies in existence, guidelines and methodology adopted since decades. The e-Procurement System of Government of Maharashtra (Mahatenders) is only change in process of accepting and evaluation of tenders.

NOTE: This tendering process is covered under Information Technology ACT & Cyber Laws as applicable

- I. In e-tendering process some of the terms and its definitions are to be read as under wherever it reflects in online tendering process.

Start Date read as "Sale Date"

End Date read as "Submission Date"

Supplier read as "Contractor/bidder"

Vendor read as "Contractor/bidder"

Vendor Quotation read as "Contractors Bid/Offer"

Purchaser read as "Department/BMC"

- II. Before entering into the online tendering process, the bidders shall complete the registration process so as to get user ID for e-tendering links. For this the bidders can access through supply registration via e-procurement system of Government of Maharashtra (Mahatenders) i.e. <https://mahatenders.gov.in>

Interested bidders shall follow the manuals available on Mahatenders portal i.e. <http://mahatenders.gov.in>

- III. E-Tendering Process

1. Tender Forms can be downloaded from e - Procurement system of Government of Maharashtra i.e. <http://mahatenders.gov.in> after entering the details of payment toward Tender Fees as per the Header Data / tender notice.
2. The tender submitted by the tenderer shall be based on clarification, additional facility issued (if any) by the BMC, and this tender shall be unconditional. Conditional tenders will be summarily REJECTED.
3. All tenderers are cautioned that the tenders containing any deviation, from the contractual terms and conditions, specifications or other requirements, and conditional tenders will be rejected as non- responsive.
4. Tenderer should have valid class III digital signature certificates (DSC) obtained from any certifying Authorities. In case of requirements of DSC, interested Bidders should go to

<https://mahatenders.gov.in>, information about DSC and follow the procedure mentioned in the document. Procedure for application of "Digital Signature Certificate".

5. Bidder should do Online Enrolment in e-procurement portal of Government of Maharashtra i.e. <https://mahatenders.gov.in> using the option Click Here to Enroll available in the Home Page. Then the Digital Signature enrolment has to be done with the e-token, after logging into the portal. The e-token may be obtained from one of the authorized Certifying Authorities such as e-Mudhra CA /GNFC IDRBT MTNL Trust line /SafeScript /TCS.
6. Bidder then logs into the portal giving user id / password chosen during enrolment.
7. The e-token that is registered should be used by the bidder and should not be misused by others.
8. DSC once mapped to an account cannot be remapped to any other account. It can only be inactivated.
9. The Bidders can update well in advance, the documents such as certificates, purchase order details etc., under My Documents option and these can be selected as per tender requirements and then attached along with bid documents during bid submission. This will ensure lesser upload of bid documents.
10. After downloading/getting the tender schedules, the Bidder should go through them carefully and then submit the documents as per the tender document, otherwise, the bid will be rejected.
11. The BOQ template must not be modified/replaced by the bidder and the same should be uploaded after filling the relevant columns, else the bidder is liable to be rejected for that tender. Bidders are allowed to enter the Bidder Name and Values only.
12. If there are any clarifications, this may be obtained online through the e-Procurement Portal, or through the contact details given in the tender document. Bidder should take into account of the corrigendum published before submitting the bids online.
13. Bidder, in advance, should prepare the bid documents to be submitted as indicated in the Header Data and they should be in PDF/XLS/RAR/DWF formats. If there is more than one document, they can be clubbed together.
14. Bidder should arrange for the EMD as specified in the tender.

15. The bidder reads the terms and conditions and accepts the same to proceed further to submit the bids.
16. The bidder has to submit the tender document (s) online well in advance before the prescribed time to avoid any delay or problem during the bid submission process.
17. There is no limit on the size of the file uploaded at the server end. However, the upload is decided on the Memory available at the Client System as well as the Network bandwidth available at the client side at that point of time. In order to reduce the file size, bidders are suggested to scan the documents in 75-100 DPI so that the clarity is maintained and also the size of file also gets reduced. This will help in quick uploading even at very low bandwidth speeds
18. It is important to note that, the bidder has to Click on the Freeze Bid Button, to ensure that he/she completes the Bid Submission Process. Bids which are not Frozen are considered as Incomplete /Invalid bids and are not considered for evaluation purposes.
19. The Tender Inviting Authority (TIA) will not be held responsible for any sort of delay or the difficulties faced during the submission of bids online by the bidders due to local issues.
20. The bidder may submit the bid documents online mode only, through this portal. Offline documents will not be handled through this system.
21. At the time of freezing the bid, the e-Procurement system will give a successful bid updating message after uploading all the bid documents submitted and then a bid summary will be shown with the bid no, date & time of submission of the bid with all other relevant details. The documents submitted by the bidders will be digitally signed using the e-token of the bidder and then submitted.
22. After the bid submission, the bid summary has to be printed and kept as an acknowledgement as a token of the submission of the bid. The bid summary will act as a proof of bid submission for a tender floated and will also act as an entry point to participate in the bid opening event.
23. Successful bid submission from the system means, the bids as uploaded by the bidder is received and stored in the system. System does not certify for its correctness.
24. The bidder should see that the bid documents submitted should be free from virus and if the documents could not be opened, due to virus, during tender opening, the bid is liable to be rejected.

25. The time that is displayed from the server clock at the top of the tender Portal, will be valid for all actions of requesting bid submission, bid opening etc., in the e-Procurement portal. The Time followed in this portal is as per Indian Standard Time (IST) which is GMT+5:30. The bidders should adhere to this time during bid submission.
 26. All the data being entered by the bidders would be encrypted at the client end, and the software uses PKI encryption techniques to ensure the secrecy of the data. The data entered will not be viewable by unauthorized persons during bid submission and not viewable by any one until the time of bid opening. Overall, the submitted bid documents become readable only after the tender opening by the authorized individual.
 27. During transmission of bid document, the confidentiality of the bids is maintained since the data is transferred over secured Socket Layer (SSL) with 256bit encryption technology. Data encryption of sensitive fields is also done.
 28. The bidders are requested to submit the bids through online e-Procurement system to the TIA well before the bid submission end date and time (as per Server System Clock).
 29. Bidder Manual Kit available on website <https://mahatenders.gov.in> for online payment of Tender Fee and EMD, submission of tender Packet 'A', 'B' and 'C', etc.
- IV. As per Three Packet system, the document for Techno-commercial Packet 'A' & 'B' are to be uploaded online by the bidder in Cover Type 'Fee / PreQual / Technical' and Price Packet 'C' is to be uploaded in Cover Type 'Finance' by the tenderer under 'Tender Covers'.
 - V. The tenderer shall pay the EMD/Bid Security through payment gateways before submission of Bid and shall upload the screenshot of receipt of payment in Packet 'A' as per bidding schedule.
 - VI. The e-tender is available on e-procurement system of Government of Maharashtra (Mahatenders) i.e. <https://mahatenders.gov.in>. The tenders duly filled in should be uploaded and submitted online on or before the end date of submission. The Packet 'A', Packet 'B' & Packet 'C' of the tenderer will be opened as per the time-table shown in the Header Data in the office of Dy. Ch.E. (Sewerage Operations) Planning & Construction.
 - VII. The Municipal Commissioner reserves the right to reject all or any of the e-Tender(s) without assigning any reason at any stage. The dates and time for submission and opening the tenders are as shown in the Header Data. If there are any changes in the dates the same will be displayed on the e-procurement portal, Government of Maharashtra i.e. <https://mahatenders.gov.in>

SECTION 6

INSTRUCTIONS TO APPLICANTS

INSTRUCTIONS TO APPLICANTS

- **Scope of Application**

The Authority wishes to receive Applications for Qualification in order to SELECT experienced and capable Applicants for the Bid Stage.

- **Eligibility of Applicants**

The Brihanmumbai Municipal Corporation (BMC) invites e-tender on percentage rate basis to appoint Contractor for the aforementioned work from contractors of repute, multidisciplinary engineering organizations i.e. eminent firm, Proprietary/Partnership Firms / Private Limited Companies / Public Limited Companies / Companies registered under the Indian Companies Act 2013, the contractors registered with the Brihanmumbai Municipal Corporation, (BMC) in Class AA as per old registration and Class A as per new registration. And from the contractors / firms equivalent and superior classes registered in Central or State Government / Semi Govt. Organization / Central or State Public Sector Undertakings, will be allowed subject to condition that, the contractors who are not registered with BMC will have to apply for registering their firm within three months time period from the award of contract, otherwise their Bid Security i.e. E.M.D (Earnest Money Deposit) will be forfeited / recovered and an amount equal to Registration Fee of respective class will be recovered as penalty.

1. For Regular, Routine and Maintenance Works:

1.1 Technical Capacity:

The tenderer(s) in their own name should have satisfactorily executed the work of similar nature in BMC /Semi Govt. /Govt. & Public Sector Organizations during last seven (7) years ending last day of month previous to the one in which bids are invited as a prime Contractor (or as a nominated sub-Contractor, where the subcontract had involved similar nature of work as described in the scope of works in this bid document, provided further that all other qualification criteria are satisfied)

- (a) Three similar completed works of value not less than the value equal to **Rs. 87,13,103/-** Or
- (b) Two similar completed works of value not less than the value equal to **Rs. 1,08,91,379/-** Or
- (c) One similar completed works of value not less than the value equal to **Rs. 1,74,26,206/-**

And

The bidder shall have ownership of at least 02 nos. of High-Capacity Suction cum Jetting Machine / High-Capacity Super Sucker Machine with dump tank. Documentary proof of the same shall be uploaded along with the tender.

The value of executed works shall be brought to current costing level by enhancing the actual value of work at compound rate of 10 % per annum; calculated from the date of completion to last date of receipt of applications for tenders.

1.2 Financial Capacity:

Achieved an average annual financial turnover as certified by 'Chartered Accountant' equal to **Rs. 1,30,69,654/-** in last three (3) financial years immediately preceding the Financial Year in which bids are invited.

- To ascertain this, tenderer(s) shall furnish /upload the financial statement (Audited balance sheet) duly certified by Chartered Accountant.
- The turnover can be enhanced by 10% every year to bring the present level.

1.3 Similar Experience:

Similar work shall mean, the completed or ongoing works of "**Cleaning / Desilting of Sewer Lines / Storm Water Drains by use of Vehicle Mounted High-Capacity Suction and / or Jetting Machine or High-Capacity Super Sucker Machine along with CCTV survey**".

2. For Original and New construction works : (Not Applicable)

C. Bid Capacity: (Not Applicable)

The bid capacity of the prospective bidders will be calculated as under: Assessed Available Bid Capacity = $(A * N^2 - B)$

Where,

A = Maximum value of Civil Engineering works executed in any one year (year means Financial year) during the last five years (updated to the price level of the Financial year in which bids are received at a rate of 10% per year) taking into account the completed as well as works in progress.

N = Number of years prescribed for completion of the Project/Works, excluding monsoon period, for which these bids are being invited. (E.g. 7 months = 7/12 year) For every intervening monsoon 0.33 shall be added to N.

B = Value of existing commitments (only allotted works) on the last date of submission of bids as per bidding document and on-going works to be completed during the period of completion of the Project/Works for which these bids are being invited.

Note: The statement showing the value of existing commitments and on-going works as well as the stipulated period of completion remaining for each of the works listed should be attached along with certificates duly signed by the Engineer-in Charge, not below the rank of an Executive Engineer or equivalent.

Even though the bidders meet the above qualifying criteria, they are subject to be disqualified if they have:

- Made misleading or false representation in the forms, statements and attachments submitted in proof of the qualification requirements; and/or
- Record for poor performance such as abandoning the works, not properly completing the contract, inordinate delays in completion or financial failures etc.

D. Equipment Capabilities as required for this work

a) Regular and Routine works:

The successful bidder will make the arrangements of the required equipment on the day of commencement or with respect to the progress of the work in phases, as per the instructions of site in charge. The successful bidder and, to that effect he will ensure commitment on an undertaking on Rs.500 stamp paper to be submitted along with the Bid in Packet B. However, this condition in no way shall dilute the respective condition in Registration Rules of BMC.

b) New and Original Works: (Not Applicable)

The bidder should, undertake their own studies and furnish with their bid, a detailed construction planning and methodology supported with assessment study of requirements of equipment/plants & machineries to allow the employer to review their proposal. The bidder will ensure his commitment to make the arrangements of the required equipment on the day of commencement or with respect to the progress of the work in phases, as per the instructions of site in charge on an

undertaking on Rs.500 stamp paper to be submitted along with the Bid in Packet B. However, this condition in no way shall dilute the respective condition in Registration Rules of BMC.

Note: Bidders shall submit the undertaking for equipment capability and other undertakings as such on a single Rs.500/- stamp paper.

E. Technical Personnel

The details of required experienced technical personnel and penalisation in case of failure in providing these experienced technical personnel are given as below.

Requirement of Technical Staff –

Requirement of Technical Staff		Minimum Experience (years)	Designation
Qualification	Number		
i. Graduate Engineer	1	5	Principal Technical Representative
ii. Graduate Engineer OR Diploma Engineer	2 OR 2	2 OR 5	Project / Site Engineer
iii. Diploma / Degree in Safety Practices by a recognized university	1 per site	2	Safety officer

Notes-

1. "Cost of work", in table above, shall mean the agreement amount of the work.
2. Rate of recovery in case of non-compliance of the clause be stipulated at following rates.

Sr. No.	Qualification	Experience (years)	Rate of Recovery
1	Project Manager with degree	10	Rs. 30000/- p.m.
2	Graduate Engineer	5	Rs. 25000/- p.m.
3	Graduate Engineer	2	Rs.15000/- p.m.
4	Diploma Engineer	5	Rs.15000/- p.m.
5	Safety Officer	2	Rs.15000/- p.m.

F. TIME PERIOD OF THE PROJECT:

Entire project should be completed and delivered within 06 months of time from the date of award of contract that Excludes Monsoon.

The time allowed for carrying out the work as entered in the Tender shall be strictly observed by the Contractor and shall be reckoned from the date on which the Letter of Acceptance is given to the Contractor. The work shall throughout the stipulated period of the Contract be proceeded with all due diligence as time being deemed to be the essence of the contract on the part of the Contractor. On failing to do so, the Contractor shall pay as compensation an amount which shall be governed as per Clause - 8(e) of Standard General Conditions of Contract.

The programme for completion of work shall be a part of the Contract Document in the form of Bar Chart / GANTT Chart. The Contractor is supposed to carry out the work and keep the progress as per Bar Chart/GANTT Chart. The Contractor shall complete the work as per the Schedule given in the Contract and the programme submitted by the Contractor.

G. Contract Execution

All required documents for execution of the contract shall be submitted within 30 days from the date of issue of letter of acceptance. If the documents are not submitted within the stipulated time, a penalty of Rs 5000/- per day will be applicable to the contractor. All contract documents need to be duly affixed with stamp duty properly signed along with evidence/proof of payment of security/contract deposit/ within 30 days from the date of letter of acceptance received by him

H. If the amount of the Contract Deposit to be paid above is not paid within 30 days from the date of issue of Letter of Acceptance, the Tender / Contract already accepted shall be considered as cancelled and legal steps be taken against the contractor for recovery of the amounts.

I. The amount of Security Deposit retained by the BMC shall be released after expiry of period up to which the contractor has agreed to maintain the work in good order is over. In the event of the contractor failing or neglecting to complete the rectification work within the period up to which the contractor has agreed to maintain the work in good order, the amount of security deposit retained by BMC shall be adjusted towards the excess cost incurred by the Department on rectification work.

J. Action when whole of security deposit is forfeited:

In any case in which under any Clause of this contract, the contractor shall have rendered himself liable to pay compensation amounting to the whole of this security deposit whether paid in one sum or deducted by instalments or in the case of abandonment of the work owing to serious illness or death of the contractor or any other cause, the Engineer on behalf of the Municipal Commissioner shall have power to adopt any of the following process, as he may deem best suited to the interest of BMC -

- a. To rescind the contract (for which recession notice in writing to the contractor under the head of Executive Engineer shall be conclusive evidence) and in that case, the security deposit of the contract shall stand forfeited and be absolutely at the disposal of BMC.
- b. To carry out the work or any part of the work departmentally debiting the contractor with the cost of the work, expenditure incurred on tools and plant, and charges on additional supervisory staff including the cost of work-charged establishment employed for getting the un-executed part of the work completed and crediting him with the value of the work done departmentally in all respects in the same manner and at the same rates as if it had been carried out by the contractor under the terms of his contract. The certificate of the Executive Engineer as to the costs and other allied expenses so incurred and as to the value of the work so done departmentally shall be final and conclusive against the contractor.
- c. To order that the work of the contractor be measured up and to take such part thereof as shall be un-executed out of his hands, and to give it to another contractor to complete, in which case all expenses incurred on advertisement for fixing a new contracting agency, additional supervisory staff including the cost of work charged establishment and the cost of the work executed by the new contract agency will be debited to the contractor and the value of the work done or executed through the new contractor shall be credited to the contractor in all respects and in the same manner and at the same rates as if it had been carried out by the contractor under the terms of his contract. The certificate of the Executive Engineer as to all the cost of the work and other expenses incurred as aforesaid for or in getting the un-executed work done by the new contractor and as to the value of the work so done shall be final and conclusive against the contractor.

In case the contract shall be rescinded under Clause (a) above, the contractor shall not be entitled to recover or be paid any sum for any work therefore actually performed by him under this contract unless and until the Executive Engineer shall have certified in writing the performance of such work and the amount payable to him in respect thereof and he shall only be entitled to be paid the amount so certified. In the event of either of the courses referred to in Clause (b) or (c) being adopted and the cost of the work executed departmentally or through a new contractor and other allied expenses exceeding the value of such work credited to the contractors amount of excess shall be deducted from any money due to the contractor, by BMC under the contract or otherwise, howsoever, or from his security deposit or the sale proceeds thereof provided, however, the contractor shall have no claim against BMC even if the certified value of the work done departmentally or through a new contractor exceeds the certified cost of such work and allied expenses, provided always that whichever of the three courses mentioned in clauses (a), (b) or (c) is adopted by the Executive Engineer, the contractor shall have no claim to compensation for any loss sustained by him by reason of his having purchase or procured any materials or entered in to any engagements or made any advance on account of or with a view to the execution of the work or the performance of the contract.

K. Contract may be rescinded and security deposit forfeited for bribing a public officer or if contractor becomes insolvent

If the contractor assigns or sublets his contracts or attempt so to do, or become insolvent or commence any proceeding to get himself adjudicated and insolvent or make any composition with his creditors, or attempt so to do or if bribe, gratuity, gift, loan, perquisite, reward or advantage, pecuniary or otherwise, shall either directly or indirectly be given promised or offered by the contractor or any of his servants or agents through any public officer, or person in the employ of BMC/Govt. in any way relating to his office or employment, or if any such officer or person shall become in any way directly or indirectly interested in the contract the Engineer In-charge may thereupon, by notice in writing rescind the contract and the Security Deposit of the Contractor shall thereupon stand forfeited and be absolutely at the disposal of BMC and the same consequences shall ensure as if the contract had been rescinded under above clause J hereof; and in addition the contractor shall not be entitled to recover or be paid for any work therefore actually performed under the contract.

- **Submission of Tenders**

PACKET - A

The Packet 'A' shall contain scanned certified copies of the following documents.

Scrutiny of this packet will be done strictly with reference to only the scanned copies of Documents uploaded online in packet 'A'

- a) Valid Registration Certificate.
- b) **Valid Bank Solvency Certificate** of Minimum Solvency amount of **Rs. 8 Lakh** as governed by Registration Rules in force for respective Class of Contractor for M&E works, issued by the bank from the approved list of banks not prior to Twelve months of due date of tender.
- c) A document in support of Registration under 'Goods & Service Tax Act, 2017. Those not registered shall submit an undertaking to the effect that if they are successful tenderer, they shall submit GST Registration Certificate within 15 days of issue of work order, failing which payment for the work executed will not be released.
- d) Certified copies of valid 'PAN' documents and photographs of the individuals, owners, Karta of Hindu undivided Family, firms, private limited companies, registered co-operative societies, partners of partnership firms and at least two Directors, if number of Directors are more than two in case of Private Limited Companies, as the case may be. However, in case of Public Limited companies, Semi Government Undertakings, Government Undertakings, no 'PAN' documents will be insisted.
- e) Latest Partnership Deed in case of Partnership firm duly registered with Chief Accountant (Treasury) of BMC.

The bidders shall categorically provide their Email ID in packet 'A'.

NOTE:

- If the tenderer(s) withdraw tender offer during the tender validity period, his entire E.M.D shall be forfeited.
- If it is found that the tenderer has not submitted required curable documents in Packet "A" then, the shortfalls will be communicated to the tenderer through e-mail only and compliance required to be made within a time period of **three working days** otherwise they will be treated as non-responsive.

PACKET - B

The Packet 'B' shall contain scanned certified copies of the following documents -

- a) The list of similar type of works as stated in para 'A' of Post qualification successfully completed during the last seven years in prescribed proforma, in the role of prime contractor. Information furnished in the prescribed Proforma (Proforma - I) shall be supported by the certificate duly self-attested.
- b) Annual financial turnover for preceding three financial years as certified by Chartered Accountant preceding the Financial Year in which bids are invited. Copies of Applicants duly audited balance sheet and profit and loss account for the preceding three financial years preceding the Financial Year in which bids are invited. (Proforma - II)
- c) Documents stating that, it has access to or has available liquid assets, unencumbered assets, lines of credit and other financial means (independent of any contractual advance payment) sufficient to meet the construction cash flow requirements for the subject contract in the event of stoppage, start-up, or other delay in payment, of the minimum 15% of the cost of the work tendered for, net of the tenderer's commitment of other contracts (Certificate from Bankers / C.A./Financial Institution shall be accepted as a evidence).
- d) The bidder shall give undertaking on Rs 500/-stamp paper that it is his/their sole responsibility to arrange the required machineries either owned/on lease or hire basis, at site before start of the work.

i. Regular and Routine works:

The successful bidder shall make the arrangements of the required equipment on the day of commencement or with respect to the progress of the work in phases, as per the instructions of site in charge. The successful bidder and, to that effect he will ensure commitment on an undertaking on Rs.500 stamp paper to be submitted along with the Bid in Packet B. However, this condition in no way shall dilute the respective condition in Registration Rules of BMC.

ii. New and Original Works: (Not Applicable)

The bidder should, undertake their own studies and furnish with their bid, a detailed construction planning and methodology supported with assessment study of requirements of equipment/plants & machineries to allow the employer to review their proposal. The bidder shall ensure his commitment to make the

arrangements of the required equipment on the day of commencement or with respect to the progress of the work in phases, as per the instructions of site in charge on an undertaking on Rs.500 stamp paper to be sub-mitted along with the Bid in Packet B. However, this condition in no way shall dilute the respective condition in Registration Rules of BMC.

- e) Details of works in hand and for which bid already submitted (Proforma VI-A & VI-B) (original), along with copies of work orders & attested copies of percentage of works completed or part thereof.
- f) ~~Statement showing assessed available Bid Capacity.~~
- g) The undertaking of Rs.500/- stamp paper as per the proforma annexed in 'Annexure B, C & E'.

Note: Bidders shall submit the undertaking for equipment capability and other undertakings as such on a single Rs.500/- stamp paper.

- h) The tenderer(s) shall upload work plan as per the following outline:
 1. GANTT chart/ PERT/ CPM chart showing the completion of work within prescribed time period, considering major activities.
 2. Organizational set up envisaged by the contractors.
 3. Plant & equipment proposed to be deployed for this work.
 4. Site Offices and Laboratories proposed to be set up.
 5. A note on how the whole work will be carried out (work plan including methodology).
 6. Quality management plan.
 7. All the activities included in the Scope of Work shall be covered in the work plan.
- i) Litigation history as per Circular no. MGC / F / 6565 dtd. 25.09.2018.

Note:

- i. The Electrical / Mechanical work shall be got carried out by the civil contractors through the contractors registered with BMC in Electrical Category. Information about the registered contractors shall be obtained from the office of the Ch.E. (M&E) / E.E. (Monitoring &Registration Cell). Attested scanned copy of the valid registration certificate in Electrical Category shall be uploaded with the tender along with the undertaking from the registered Electrical Contractor stating his willingness to carry out the tender work.

- ii. The successful bidder shall submit valid registration certificate under E.S.I.C., Act 1948, if the tenderer has more than 10 employees /persons on his establishment (in case of production by use of energy) and 20 employees/persons on his establishment (in case of production without use of energy) to BMC as and when demanded. In case of less employees/persons mentioned above then the successful bidder has to submit an undertaking to that effect on Rs. 200 stamp paper as per circular u/no. CA/FRD/I/65 of 30.03.2013.
- iii. The successful bidder shall submit valid registration certificate under E.P.F. & M.P., Act 1952, if tenderer has more than 20 employees/persons on his establishment, to BMC as and when demanded. In case if the successful bidder has less employees/persons mentioned above then the successful bidder has to submit an undertaking to that effect on Rs. 200 stamp paper as per circular u/no. CA/FRD/I/44 of 04.01.2013.

Note:

- If it is found that the tenderer has not submitted required documents in Packet “B” then, the shortfalls will be communicated to the tenderer through e-mail only and compliance required to be made within a time period of **three working days** otherwise they will be treated as non-responsive.

PACKET – C

Online tender filled in either plus or minus (above or below) or at par. (There is no separate provision to quote % in physical form, this is a part in Header Data of online Tendering). For Packet 'C' tenderer(s) will fill data in 'Item Data Tab' in Service Line Item via Details and quote his percentage variation figures. **(If entered '0' it will be treated as 'at par'**. By default, the value is zero only).

Note: In case of rebate/premium of 15% and above as quoted by the tenderer, the rate analysis of major items shall be submitted by L1 and L2 bidder after demand notification by e-mail to bidders by concerned Dy.Ch.Eng. The format for rate analysis is annexed at Annexure D.

The tenderer shall quote inclusive of all taxes other than GST (Excluding GST), Levies, Duties, Cess etc. as applicable at the time of bid submission. GST as applicable shall be paid separately on submission of bills/invoice.

BID SECURITY OR EMD

- The Bidder shall furnish, as part of the Bid, Bid Security/EMD, in the amount specified in the Bid Data Sheet. This bid security shall be in favour of the authority mentioned in the Bid Data Sheet and shall be valid till the validity of the bid.
- A tenderer shall pay entire amount of EMD through payment gateways of GoM on URL <https://mahatenders.gov.in>. The bidder shall upload scan copy of online paid EMD along with the bid submission in Packet 'A'.
- Any bid not accompanied by an acceptable Bid Security shall be rejected by the Employer as non-responsive.
- If the bidder is found non-responsive after scrutiny of Packet 'A' / 'B', in such circumstances, the bidder will be made non-responsive and financial packet 'C' of non-responsive bidder will not be opened. However, there will not be any forfeiture of EMD. The Bid Security/ EMD and ASD of L-2 and higher bidders (L-3, L-4, etc.) shall be refunded immediately after opening of financial bid.
- Maximum 5 shortfalls of curable defects shall be allowed and in case, curable defects are not complied by the bidder within given time period, the bidder shall be treated as 'Non-Responsive' and such cases will be informed to Registration and Monitoring Cell. Such non-submission of documents will be considered as 'Intentional Avoidance' and if three or more cases in 12 months are reported, shall be viewed seriously and disciplinary action against the defaulters such as banning/de-registration, etc. shall be taken by the Registration Cell with due approval of the concerned AMC.
- Except successful bidder all other unsuccessful bidder's 100% EMD paid online will be refunded automatically.
- The Bid Security/ EMD of the successful Bidder will be discharged when the Bidder has signed the Agreement and furnished the required Security Deposits as elaborated in Standard Bid Document.
- The existing conditions laid down in Standard Bid Document regarding forfeiture of entire bid security (EMD) shall remain unchanged.
- In case, the successful bidder becomes non responsive or successful bidder withdraws the bid or is unwilling to extend the bid validity period, in such circumstances, if L-2 bidder is agreeable to extend the bid validity period and ready to deposit the requisite amount of bid security /EMD and ASD to the department within the stipulated time period i.e. 15 days, the department will process further as per normal procedure.

- The Bid Security may be forfeited:
 - a. if the Bidder withdraws the Bid after bid opening (opening of technical qualification part of the bid during the period of Bid validity;
 - b. in the case of a successful Bidder, if the Bidder fails within the specified time limit to:
 - i. sign the Agreement; and/or
 - ii. Furnish the required Security Deposits.

Note:

- i. **Curable Defect shall mean shortfalls in submission such as:**
 - a. **Non-submission of following documents,**
 - i. **Valid Registration Certificate**
 - ii. **Valid Bank Solvency**
 - iii. **GST Registration Certificate**
 - iv. **Certified Copies of PAN documents and photographs of individuals, owners, etc.**
 - v. **Partnership Deed and any other documents**
 - vi. **Undertakings as mentioned in the tender document.**
- ii. **Non-curable Defect shall mean**
 - a. **In-adequate submission of EMD/ASD amount,**
 - b. **In-adequacy of technical and financial capacity with respect to Eligibility criteria as stipulated in the tender.**
 - c. **Wrong calculation of Bid Capacity,**
 - d. **No proper submission of experience certificates and other documents, etc.**

BID VALIDITY

- **Bids shall remain valid for a period of not less than **ONE Eighty (180) days** after the deadline date for bid submission specified in Bid Data Sheet. A bid valid for a shorter period shall be rejected by the Employer as non-responsive.**

In exceptional circumstances, prior to expiry of the original time limit, the Employer may request that the bidders may extend the period of validity for a specified additional period. The request and the bidders' responses shall be made in writing or by cable. A bidder may refuse the request without forfeiting his Bid Security. A bidder agreeing to the request will not be required or permitted to modify his bid, but will be required to extend the validity of his bid security for a period of the extension.

DEFECT LIABILITY PERIOD

- The Contractor is expected to carry out the construction work in Workmen like manner so as to meet the requirement and specification for the project. It is expected that the Workmanship and materials will be reasonably fit for the purpose for which they are required.
- Defects or defective work is where standard and quality of workmanship and materials as specified in the contract is deficient. Defect is defined as a failure of the completed project to satisfy the express or implied quality or quantity obligations of the construction contract. Defective construction works are as the works which fail short of complying with the express descriptions or requirements of the contract, especially any drawings or specifications with any implied terms and conditions as to its quality, workmanship, durability, aesthetic, performance or design. Defects in construction projects are attributable to various reasons.
- Some of the defects are structural defects results in cracks or collapse of faulty defective plumbing, inadequate or faulty drainage system, inadequate or faulty ventilation, cooling or heating systems, inadequate fire systems etc. The defects could be various on accounts of different reasons for variety of the projects.
- The Engineering In charge/Project Officer shall issue the practical completion certificate for the project. During the Defect Liability Period which commences on completion of the work, the Engineering In charge shall inform or the contractor is expected to be informed of any defective works by the Employer's representative of the defects and make good at contractor's cost with an intention of giving opportunity to the contractor of making good the defects appeared during that period. It is the contractor's obligation under the contract to rectify the defects that appear during Defect Liability Period and the contractor shall within a reasonable time after receipt of such instructions comply with the same at his own cost. The Engineering In charge/Project Officer shall issue a certificate to that effect and completion of making good defects shall be deemed for all the purpose of this contract to have taken place on the day named in such defect liability certificate.

- If defective work or workmanship or design has been knowingly covered-up or concealed so as to constitute fraud, commencement of the Defect Liability Period may be delayed. The decided period may be delayed until discover actually occurs on at least the defect could have been discovered with reasonable diligence, whichever is earlier.
- The Defect Liability Period (DLP) for the work is 03 Years.
- Also, in case of defect, the Engineer shall give notice to the Contractor of any Defects before the end of the Defects Liability Period, which begins at. The Defects Liability Period shall be extended for as long as Defects remain to be corrected. Every time notice of Defect/Defects is given, the Contractor shall correct the notified Defect/Defects within the duration of time specified by the Engineer's notice. The Engineer may issue notice to the Contractor to carry out removal of defects or deficiencies, if any, noticed in his inspection, or brought to his notice. The Contractor shall remove the defects and deficiencies within the period specified in the notice and submit to the Engineer a compliance report.
- It is the Completion Stage when the contractor has completed all of the works and fixed all of the defects that were on the list of issue by Engineer-in-charge. When this happens, the engineer must issue a 'Certificate of Completion'. On the issue of 'Certificate of Completion', the 'Defect Liability Period' starts. The contractor also must issue a 'Certificate statement' as an acknowledgment to the engineer not later than 14 days after the 'Certificate of Completion' has been issued. During the 'Defect Liability Period', the contractor has to obey all written instructions from the engineer to carryout repairs and fix any defects which appear in the Permanent Works. If the contractor does not, due to his own faults finish the repair works or fix the defects by the end of 'Defect Liability Period', the 'Defect Liability Period' will continue until all works instructed by engineer is done.

SECURITY DEPOSIT AND PERFORMANCE GUARANTEE

A. Security Deposit

The security deposit shall mean and comprise of

- I. Contract Deposit and
 - II. Retention Money.
- I. **Contract Deposit** - The successful tenderer, hereafter referred to as the contractor shall pay an amount equal to **two (2) percent** of the contract sum as a Contract Deposit within thirty days from the date of issue of letter of acceptance.
 - II. **Retention Money** - The contractor shall pay the retention money an amount equal to **five (5) percent** of the Contract Sum which will be recovered from the contractors every bill i.e. interim / running / final bill. The clause of retention money will not be applicable M. & E. Department.

B. Additional Security Deposit (Please refer ASD circular at Annexure 'M').

1. If the Lowest bidder quotes rebate less than 12% then the applicable additional security deposit (ASD) at the rate of 1% for each percentage quoted below 12% will not require to be paid online while submission of tender online.
2. After sanction/approval of competent authority to the contract cost, the lowest bidder shall deposit ASD in the Municipal Citizen Facility Centres in the form of demand draft as mentioned in Letter of Acceptance (LOA) within 15 working days as per prevailing practice and the receipt of the same shall be submitted to Head of department.
3. If the first lowest bidder will not paid ASD within 15 working days after issue of LOA, then the EMD paid by the concern company will be forfeited and the company will be debarred for two years, similarly if the director/partner of the company is also working in other company as a director/partner then said company will also be debarred for two years.

C. Performance Guarantee

The successful tenderer, hereafter referred to as the contractor shall pay in the form of “Performance Guarantee” at different rates for different slabs as stated below:

Offer	PG applicable %
For premium, at par and rebate 0 to 12%	PG= 0.92% x contract sum applicable for rebate of 12%
For rebate of 12.01% and more	P.G. = {0.92% x contract sum applicable for rebate of 12%} + (X) x contract sum where, X= percentage rebate quoted more than 12%

Note: Contract sum shall mean amount after application of rebate/premium as quoted by the contractor with contingencies only and excluding price variation.

The PG shall be paid in one of the following forms.

- I. Cash (In case guarantee amount is less than Rs.10,000/-)
- II. Demand Draft (In case guarantee amount is less than Rs.1,00,000/-)
- III. Government securities
- IV. Fixed Deposit Receipts (FDR) of a Schedule Bank.
- V. An electronically issued irrevocable bank guarantee bond of any Schedule bank or in the prescribed form given in Annexure.

Performance Guarantee is applicable over and above the clause of Security Deposit. Performance Guarantee will have to be paid & shall be valid till the defect liability period or finalization of final bill whichever is later.

This deposit will be allowed in the form of I to V as mentioned above and shall be paid within 15 days after receipt of Letter of Acceptance.

Note: Following exceptions shall be adopted for ‘Demolition Tenders’:

- Irrespective of the offer (Rebate/ at par/ premium), ASD shall be differed and only PG of 10% of contract sum be taken from the successful bidder on award of contract only.
- BMC departments shall ensure to incorporate specific condition regarding above in bid document and e-tender notice.

D. Refund of Security Deposit

I. Refund of Contract Deposit

The Contract Deposit shall be released within 30 days after completion of 3rd year of DLP (in case of 5 years DLP) and after issue of 'Defect Liability Certificate' (in case of 1 or 2 or 3 years DLP) subject to no recoveries are pending against the said work, provided that the Engineer is satisfied that there is no demand outstanding against the Contractor. No claim shall be made against the Balance Contract Deposit after the issue of Defects Liability Certificate.

II. Refund of Retention Money

One-half (50%) of the Retention Money shall be released within 30 days of issue of 'Certificate of Completion' with respect to the whole of the Works. In the event the Engineer issues a Taking-over Certificate for a section or part of the Permanent Works, only such proposition thereof as the Engineer determines (having regard to the relative value of such section or part of the Works) shall be considered by the Engineer for payment to the Contractor.

The balance Retention Money shall be released within 30 days after completion of 3rd year of DLP (in case of 5 years DLP) and after issue of 'Defect Liability Certificate' (in case of 1 or 2 or 3 years DLP) provided that the Engineer is satisfied that there is no demand outstanding against the Contractor. In the event of different Defects Liability Periods have been specified or become applicable to different sections or parts of the Permanent Works, the said moneys will be released within 30 days on expiration of the latest of such Defects Liability Periods.

Payment of the above mentioned 50% is exclusive of the amounts to be withheld as stated in and that amount shall be paid as per condition stated therein.

III. **Refund of Additional Security Deposit**

The additional security deposit shall be released within 30 days of issue of 'Certificate of Completion' with respect to the whole of the Works. In the event the Engineer issues a Taking-over Certificate for a section or part of the Permanent Works, only such proposition thereof as the Engineer determines (having regard to the relative value of such section or part of the Works) shall be considered by the Engineer for payment to the Contractor.

IV. **Refund of Performance Guarantee**

The Deposit on account of performance guarantee shall be released within 30 days of completion of Defects Liability Certificate subject finalization of final bill whichever is later and no recoveries are pending against the said work, provided that the Engineer is satisfied that there is no demand outstanding against the Contractor.

• **Summary of time of Refund of deposit is tabulated as follows:**

a. Time of Refund for works having 5 years DLP

Deposits refunded after Completion	After 3 yrs of DLP	After Completion of DLP
ASD + 50% of RM	CD+50% of RM	PG

b. Time of Refund for works having 1 or 2 or 3 years DLP

Deposits refunded after completion	After Completion of DLP
ASD + 50% of RM	CD+50% of RM+PG

Note:

- i. It shall be clearly mentioned that the BG shall be applicable for individual work/contract and clubbing of various contracts of the said contractor will not be allowed. In case of obtaining Bank Guarantee, it is necessary to mention that the same shall be valid further 6 months from the completion of defect liability period/warranty period.

- ii. It shall be the responsibility of the bidder to keep the submitted B.G. "VALID" for the stipulated time period in the tender & in case of its expiry it will attract penalization.
- iii. Bank Guarantee should be issued by way of General Undertaking and Guarantee issued on behalf of the Contractor by any of the Nationalized or Scheduled banks or branches of foreign banks operating under Reserve Bank of India regulations located in Mumbai upto Virar & Kalyan. List of approved Banks is appended at the end of Instructions to Bidders (ITB). The Bank Guarantee issued by branches of approved Banks beyond Kalyan and Virar can be accepted only if the said Bank Guarantee is countersigned by the Manager of a Regional Branch of the same bank within the Mumbai City Limit categorically endorsing thereon that the said Bank Guarantee is binding on the endorsing Branch of the Bank or the Bank itself within Mumbai Limits and is liable to be enforced against the said Branch of the Bank or the bank itself in case of default by the Contractors furnishing the Bank Guarantee. The Bank Guarantee shall be renewed as and when required and/or directed from time to time until the Contractor has executed and completed the works and remedied any defects therein.

E. Legal + Stationary Charges:

Successful tenderer shall pay the Legal Charges + Stationary charges as per Circular no. 26206 dated 31.08.2023 as per Annexure-K or latest circular in this regard.

The tenderers are requested to note that stationary charges as given in the circular will be recovered from the successful tenderer for supply of requisite prescribed forms for preparing certificate bills in respect of the work.

F. Stamp Duty: (As per latest applicable circular)

It shall be incumbent on the successful tenderer to pay stamp duty on the contract.

- i. As per the provision made in Article 63, Schedule I of Bombay Stamp Act 1958, stamp duty is payable for "works contract" that is to say, a contract for works and labour or services involving transfer of property in goods (whether as goods or in some other form) in its execution and includes a sub-contract, as under:

(a)	Where the amount or value set forth in such contract does not exceed rupees ten lakh.	Five Hundred rupees stamp duty
(b)	Where it exceeds rupees ten lakhs	Five hundred rupees plus 0.1% of the amount above Rs. 10,00,000/- subject to the maximum of rupees twenty five lakh stamp duty.
(c)	Bank guarantee: As per article 54 read with 40(b) of stamp duty act, stamp duty of 0.5% will be applicable to the all bank guarantee submitted also which are required to be renewed after expiry of time period.	

- ii. The successful bidder shall enter into a contract agreement with B.M.C. within 30 days from the date of issue of Work Order and the same should be adjudicated for payment of Stamp Duty by the successful bidder.
- iii. Further shortfall if any, in amount of stamp duty paid as against prescribed amount for the documents executed in Mumbai City & Mumbai Suburban District be recovered from the concerned work contractors and to deposit the deficit or unpaid Stamp Duty and penalty by two separate Demand Draft or Pay Order in favour of "Superintendent of Stamp, Mumbai" within 15 days from intimation thereof.
- iv. All legal charges and incidental expenses in this respect shall be borne and paid by the successful tenderer.

IMPORTANT DIRECTIONS

1. All the information uploaded shall be supported by the corroborative documents in absence of which the information uploaded will be considered as baseless and not accepted for qualification criteria. All the documents shall be uploaded with proper pagination. The page No. shall be properly mentioned in the relevant places.

The information shall be uploaded in the sequence as asked for with proper indexing etc. The Bidder shall be fully responsible for the correctness of the information uploaded by him.

2. TENDERERS ARE REQUESTED TO GO THROUGH THE e-TENDER GUIDELINES ON NIC PORTAL (<https://mahatenders.gov.in>). For registration, enrolment for digital signature certificate & user manual, please refer to respective links provided in e-tendering tab. The vendors can get digital signature from any one of the Certifying Authorities (CA's) licensed by the Controller of Certifying Authorities namely Safes crypt, IDRBT, National Informatics Centre, TCS, Customs, MTNL, GNFC and e- Mudhra.

Any queries or request for additional information concerning this TENDER shall be submitted by e-mail to eepnme.so@mcgm.gov.in. The subject shall clearly bear the following identification/ title: "Queries/ Request for Additional Information: TENDER for Systematic Cleaning of Sewers of sizes 600mm and below in Eastern Suburb Area. Any changes in mail ID will be intimated on the portal.

3. In case of **Equal percentage** of lowest bidders (L1), the allotment of work shall be done by giving 48 hrs (**2 working days**) from the day of opening of packet C **on same BID-Document number for re-quoting** and such development needs to done by IT department in BMC's SRM system. **Till such development is made; 'Sealed Bids' shall be called from the bidders quoting the same percentage i.e. L1.**

In case of equal percentage of lowest bidders is obtained even after re-quoting, then the successful bidder will be decided by lottery system by concerned Chief Engineer.

The bidder shall need to submit the additional ASD if applicable within 15 days after receipt of notification issued by concerned Chief Engineer.

Also, the Performance Guarantee shall be paid in 15 days after receipt of Letter of Acceptance.

4. **Not withstanding Joint Venture is not allowed in the instance tender.**
5. **GST: As per latest circular no: CA/F/P/28 dtd: 28.03.2023 (Refer Annexure “N”)**

The tenderer shall quote inclusive of all taxes other than GST **(Excluding GST)**, Levies, Duties, Cess etc as applicable at the time of bid submission. GST as applicable shall be paid separately on submission of bills/invoice.

Input Tax Credit of GST as available with the bidder will not be claim separately by BMC. However, while quoting the rates benefit of Input Tax Credit or Exemptions shall be passed on to the BMC by way of equivalent reduction in quoted price.

SECTION 7

SCOPE OF WORK

SCOPE OF WORK

Subject: Systematic Cleaning of Sewers of sizes 600mm and below in Eastern Suburb Area.

Brihanmumbai Municipal Corporation has sewer network of about 2123 kms having various sizes of man-entry and non-man entry sewer lines. In the present tender, BMC intends to undertake of systematic de-silting of selected sewer lines of circular shape and sizes 600mm and below located in Eastern Suburb (E.S.) area with specialised vehicle equipped with high-capacity suction cum jetting machine / high-capacity super sucker machine with dump tank facility. The schedule of sewer lines included in the scope of work is as follows.

List of Sewer Stretches under the Scope of Work

Sr. No.	Sewer Stretch / Location	Ward	Size & Shape of Sewer (mm)	Tentative Length As per GIS (mtr)
1.	Ashok Nagar, Marwa Rd., Sakinaka.	L	500/600 (Circular)	306
2.	RC Marg (From Bharat Petroleum mono station to Micado Bar)	M/W	500 (Circular)	1941
3.	Periphery Road (From Kena Market Maidan to GMLR Jn.)	M/E	600 (Circular)	768
4.	V. N. Purav Marg (From Deonar Farm Road Jn. to Anushakti Nagar)	M/E	600 (Circular)	1106

Total length of sewer lines to be de-silted under this project is **4121 mtr.**

The aforementioned sewer lines to be de-silted are located in densely populated area and are age old made of concrete or concrete lined bricks. These sewer lines are yet to be rehabilitated. These sewer lines are envisaged to be heavily silted to the extent of 40% to 60% and as a result the connected sewer network remains in surcharge condition giving rise to unhygienic and unhealthy conditions causing inconvenience to the locals.

As such, the subject tender is invited for de-silting of aforementioned sewer lines with specialised vehicle mounted high-capacity suction cum jetting machine/ high capacity super suction machine with dump tank facility. In addition to this, it is expected that the successful Contractors shall undertake dimension check of the sewer lines in the scope of work as per the requirement.

Contractors are requested to refer to the Contract Drawings for tentative alignment and start and end points of the aforementioned sewer lines under the scope of work.

SECTION 8

BILL OF QUANTITIES

BRIHAN MUMBAI MUNICIPAL CORPORATION
(Sewerage Operation Department)

Subject - Systematic Cleaning of Sewers of sizes 600mm and below in Eastern Suburb Area.

BILL OF QUANTITIES AND RATES

Sr. No.	Item Description	Qty	Unit	Rate	Amount
1	Temporary plugging of sewer line / laterals as per specifications.	10	NOS	21,450.00	2,14,500.00
2	Permanent plugging of sewer line as per specifications. (For Circular size of 500 mm dia.)	7	NOS	2,194.00	15,358.00
3	Permanent plugging of sewer line as per specifications. (For Circular size of 600 mm dia.)	9	NOS	5,372.00	48,348.00
4	Excavation of required size trenches on road for laying sewage flow by-pass pipes as per specification. Size of pit - 1 mtr (L) x 1 mtr. (W) x 1.5 mtr. (D)	49	MTR	4,783.00	2,34,367.00
5	Diversion of flows by pumping as per specifications (For all sizes under the scope of work)	4121	MTR	3,066.00	1,26,34,986.00
6	Desilting and transporting the desilted material to the identified dumping site as per specifications. (For all sizes under the scope of work)	4121	MTR	5,485.00	2,26,03,685.00

7	Colour CCTV Survey as per specifications. (For all sizes under the scope of work)	4121	MTR	432.00	17,80,272.00
8	Manhole Repairs as per specifications.	147	NOS	33,230.00	48,84,810.00
9	Raising / lowering of manholes as per specifications	15	NOS	1,628.00	24,420.00
10	Replacement of manhole cover and frame (Circular)	8	NOS	22,576.00	1,80,608.00
11	Replacement of manhole cover and frame (Scraper)	8	NOS	27,168.00	2,17,344.00
12	Replacement of manhole cover and frame (Double Scrapper)	8	NOS	90,852.00	7,26,816.00
Total Estimated Cost					4,35,65,514.00

Note – For Packet ‘C’, tenderer(s) will fill data in ‘Item Data Tab’ of online tendering in Service Line Item via Details and quote his percentage variation figures. (If entered ‘0’ it will be treated as ‘at par’. By default, the value is zero only).

1. The tenderer shall quote inclusive of all taxes other than GST (Excluding GST), Levies, Duties, Cess etc. as applicable at the time of bid submission. GST as applicable shall be paid separately on submission of bills/invoice.

SECTION 9

GENERAL CONDITIONS OF CONTRACT

(The Standard General Conditions of Contract for Construction Works, 2016 of the Brihanmumbai Municipal Corporation (with the latest amendments) shall apply for this work. In case of any error, the Standard G.C.C. published by B.M.C. on its website will govern.)

General Conditions of Contract

A. General

1. Definitions

Terms which are defined in the Contract Data are not also defined in the Conditions of Contract but keep their defined meanings. Capital initials are used to identify defined terms.

The “Contract” shall mean the tender and acceptance thereof and the formal agreement if any, executed between the Contractor, Commissioner and the Corporation together with the documents referred to therein including these conditions and appendices and any special conditions, the specifications, designs, drawings, price schedules, bills of quantities and schedule of rates. All these documents taken together shall be deemed to form one Contract and shall be complementary to one another.

The Contract Data defines the documents and other information which comprise the Contract.

The “Contractor” shall mean the individual or firm or company whether incorporated or not, whose tender has been accepted by the employer and the legal successor of the individual or firm or company, but not (except with the consent of the Employer) any assignee of such person. **The Bidder** is a person or corporate body who has desired to submit Bid to carry out the Works, including routine maintenance till the tender process is concluded.

The Contractor's Bid is the completed bidding document submitted by the Contractor to the Employer.

The “Contract Sum” means the sum named in the letter of acceptance including Physical contingencies subject to such addition thereto or deduction therefrom as may be made under the provisions hereinafter contained.

Note: The contract sum shall include the following -

- In the case of percentage rate contracts, the estimated value of works as mentioned in the tender adjusted by the Contractor’s percentage.

- In the case of item rate contracts, the cost of the work arrived at after finalisation of the quantities shown in schedule of items / quantities by the item rates quoted by the tenderers for various items and summation of the extended cost of each item.
- In case of lump sum contract, the sum for which tender is accepted.
- Special discount / rebate / trade discount offered by the tenderer if any and accepted by the Corporation.
- Additions or deletions that are accepted after opening of the tenders.

The “Contract Cost” means the Contract Sum plus Price Variation. This cost shall be included in the letter of acceptance.

A Defect is any part of the Works not completed in accordance with the Contract.

The Defects Liability Certificate is the certificate issued by the Engineer, after the Defect Liability Period has ended and upon correction of Defects by the Contractor.

Drawings means all the drawings, calculations and technical information of a like nature provided by the Engineer to the Contractor under the Contract and all drawings, calculations, samples, patterns, models, operation & maintenance manual and other technical information of like nature submitted by the Contractor and approved by the Engineer.

The Authority shall mean Brihanmumbai Municipal Corporation (BMC)

The “Employer” shall mean the Brihanmumbai Municipal Corporation / Municipal Commissioner for Brihan Mumbai, for the time being holding the said office and also his successors and shall also include all “Additional Municipal Commissioners, Director (Engineering Services & Projects)” and the Deputy Municipal Commissioner, to whom the powers of Municipal Commissioner, have been deputed under Section 56 and 56B of the Mumbai Municipal Corporation Act.

The Engineer in-charge shall mean the Executive Engineer in executive charge of the works and shall include the superior officers of the Engineering department i.e. Dy.Ch.Eng / Ch.Eng. and shall mean and include all the successors in BMC

The Engineer's Representative shall mean the Assistant Engineer, Sub. Engineer/Jr. Engineer in direct charge of the works and shall include Sub Eng./ Jr. Eng of Civil section/ Mechanical section/ Electrical section appointed by BMC.

The "Engineer" shall mean the City Engineer / the Hydraulic Engineer / the Chief Engineer / the Special Engineer, appointed for the time being or any other officer or officers of the Municipal Corporation who may be authorized by the commissioner to carry out the functions of the City Engineer / the Hydraulic Engineer / the Chief Engineer / the Special Engineer or any other competent person appointed by the employer and notified in writing to the Contractor to act in replacement of the Engineer from time to time.

Contractor's Equipment means all appliances and things of whatsoever nature required for the execution and completions of the Works and the remedying of any defects therein, but do not include plant material or other things intended to formor forming part of the Permanent Works.

The Initial Contract Price is the Contract Price listed in the Employer's Letter of Acceptance.

The Intended Completion Date is the date on which it is intended that the Contractor shall complete the construction works. The Intended Completion Date is specified in the Contract Data. The Intended Completion Date may be revised only by the Engineer by issuing an extension of time.

Materials are all supplies, including consumables, used by the Contractor for incorporation in the Works and works of routine maintenance. **Plant** is any integral part of the Works that shall have a mechanical, electrical, electronic, chemical, or biological function.

Routine Maintenance is the maintenance of activities of the competed structure for five years as specified in the Contract Data.

The "Site" shall mean the land and other places including water bodies more specifically mentioned in the special conditions of the tender, on, under in or through which the permanent works or temporary works are to be executed and any other

lands and places provided by the Municipal Corporation for working space or any other purpose as may be specifically designated in the contract as forming part of the site.

Site Investigation Reports are those that were included in the bidding documents and are reports about the surface and subsurface conditions at the Site.

“Specification” shall mean the specification referred to in the tender and any modification thereof or addition or deduction thereto as may from time to time be furnished or approved in writing by the Engineer.

The Start Date/Commencement Date is given in the Contract Data. It is the date when the Contractor shall commence execution of the Works. It does not necessarily coincide with any of the Site Possession Dates.

A Nominated Sub-Contractor is a person or corporate body who has a Contract with the Contractor to carry out a part of the construction work and/or routine maintenance in the Contract, which includes work on the Site.

Temporary Works are works designed, constructed, installed, and removed by the Contractor that are needed for construction or installation of the Works.

Variation means a change to the:-

Specification and /or Drawings (if any) which is instructed by the Employer.

- Scope in the Contract which is instructed by the Employer.
- Price in the Contract which is instructed by the Employer.

The Works, as defined in the Contract Data, are what the Contract requires the Contractor to construct, install, maintain, and turn over to the Employer. Routine maintenance is defined separately.

Jurisdiction: In case of any claim, dispute or difference arising in respect of a contract, the cause of action thereof shall be deemed to have arisen in Mumbai and all legal proceedings in respect of any claim, dispute or difference shall be instituted in a competent court in the City of Mumbai only.

2. Interpretation

- 2.1. In interpreting these Conditions of Contract, singular also means plural, male also means female or neuter, and the other way around. Headings have no significance. Words have their normal meaning under the language of the Contract unless specifically defined. The Engineer will provide instructions clarifying queries about these Conditions of Contract.
- 2.2. If sectional completion is specified in the Contract Data, references in the Conditions of Contract to the Works, the Completion Date, and the Intended Completion Date apply to any Section of the Works (other than references to the Completion Date and Intended Completion Date for the whole of the Works).
- 2.3. The documents forming the Contract shall be interpreted in the following documents: (1) Agreement,(2) Letter of Acceptance,(3) Notice to Proceed with the Work, (4)Contractor's Bid, (5)Contract Data,(6)Special Conditions of Contract Part (7)General Conditions of Contract Part I, (8) Specifications, (9) Drawings, (10) Bill of Quantities, and (11) Any other document listed in the Contract Data

3. Engineer's Decisions

- 3.1. Except where otherwise specifically stated, the Engineer will decide contractual matters between the Employer and the Contractor in the role representing the Employer. However, if the Engineer is required under the rules and regulations and orders of the Employer to obtain prior approval of some other authorities for specific actions, he will so obtain the approval, before communicating his decision to the Contractor.
- 3.2. Except as expressly stated in the Contract, the Engineer shall not have any authority to relieve the Contractor of any of his obligations under the contract.

4. Delegation

The Engineer, with the approval of the Employer, may delegate any of his duties and responsibilities to other person(s), except to the Adjudicator, after notifying the Contractor, and may cancel any delegation after notifying the Contractor.

5. Communications

All certificates, notices or instructions to be given to the Contractor by Employer/ Engineer shall be sent on the address or contact details given by the Contractor of Bid. The address and contact details for communication with the Employer/ Engineer shall be as per the details given in Contract Data. Communications between parties that are referred to in the conditions shall be in writing. The Notice sent by facsimile (fax) or other electronic means shall be effective on confirmation of the transmission. The Notice sent by Registered post or Speed post shall be effective on delivery or at the expiry of the normal delivery period as undertaken by the postal service

6. Subcontracting

- 6.1. Unless specifically mentioned in the contract subletting will not be allowed. Subletting, where otherwise provided by the contract shall not be more than 25% of the contract price.
- 6.2. The Contractor shall not be required to obtain any consent from the Employer for:
 - i. the sub-contracting of any part of the Works for which the Subcontractor is named in the Contract;
 - ii. the provision for labour, or labour component.
 - iii. the purchase of Materials which are in accordance with the standards specified in the Contract
- 6.3. Beyond what has been stated in clauses 6.1 and 6.2, if the Contractor proposes sub-contracting any part of the work during execution of the Works, because of some unforeseen circumstances to enable him to complete the Works as per terms of the Contract, the Employer will consider the following before according approval:
 - a. The Contractor shall not sub-contract the whole of the Works.
 - b. The permitted subletting of work by the Contractor shall not establish any contractual relationship between the sub-contractor and the BMC and shall not relieve the Contractor of any responsibility under the Contract.

- 6.4. The Engineer should satisfy himself before recommending to the Employer whether,
- a. the circumstances warrant such sub-contracting; and
 - b. the sub-Contractor so proposed for the Work possesses the experience, qualifications and equipment necessary for the job proposed to be entrusted to him.

7. Other Contractors

- 7.1. The Contractor shall cooperate and share the Site with other Contractors, public authorities, utilities, and the Employer between the dates given in the Schedule of Other Contractors, as referred to in the Contract Data. The Contractor shall also provide facilities and services for them as described in the Schedule. The Employer may modify the Schedule of Other Contractors, and shall notify the Contractor of any such modification.
- 7.2. The Contractor should take up the works in convenient reaches as decided by the Engineer to ensure there is least hindrance to the smooth flow and safety of traffic including movement of vehicles and equipment of other Contractors till the completion of the Works.

8. Personnel

- 8.1. The Contractor shall employ for the construction work and routine maintenance the key personnel including technical personnel named in the Contract Data or other personnel approved by the Engineer. The Engineer will approve any proposed replacement of technical personnel only if their relevant qualifications and abilities are substantially equal to those of the personnel stated in the Contract Data.
- 8.2. The Contractor's personnel shall appropriately be qualified, skilled and experienced in their respective trades or occupations. The Engineer shall have authority to remove, or cause to be removed, any person employed on the site or works, who carries out duties incompetently or negligently and persists in any conduct which is prejudicial to safety, health or the protection of the environment.

- 8.3. If the Engineer asks the Contractor to remove a person who is a member of the Contractor's staff or work force, stating the reasons, the Contractor shall ensure that the person leaves the Site within seven days and has no further connection with the Works in the Contract.
- 8.4. The Contractor shall not employ any retired Gazetted officer who has worked in the Engineering Department of the BMC /State Government and has either not completed two years after the date of retirement or has not obtained BMC/State Government's permission to employment with the Contractor.

9. Employer's and Contractor's Risks

The Employer carries the risks which this Contract states are Employer's risks, and the Contractor carries the risks which this Contract states are Contractor's risks.

10. Employer's Risks

The Employer is responsible for the excepted risks which are (a) in so far as they directly affect the execution of the Works in the Employer's country, the risks of war, invasion, act of foreign enemies, rebellion, revolution, insurrection or military or usurped power, civil war, riot, commotion or disorder (unless restricted to the Contractor's employees) and contamination from any nuclear fuel or nuclear waste or radioactive toxic explosive, or (b) a cause due solely to the design of the Works, other than the Contractor's design.

11. Contractor's Risks

- 11.1 All risks of loss of or damage to physical property and of personal injury and death which arise during and in consequence of the performance of the Contract other than the excepted risks, referred to in clause 11.1, are the responsibility of the Contractor.

12. Insurance

- 12.1. The Contractor at his cost shall provide, in the joint names of the Employer and the Contractor, insurance cover from the Start Date to the end of Defects Liability Period, in the amounts and deductibles stated in the Contract Data for the following events which are due to the Contractor's risks:

- a. Loss of or damage to the Works, Plant and Materials;
- b. Loss of or damage to Equipment;
- c. Loss of or damage to property (other than the Works, Plant, Materials, and Equipment) in connection with the Contract; and
- d. Personal injury or death.

12.2. Insurance policies and certificates for insurance shall be delivered by the Contractor to the Engineer for the Engineer's approval before the Start Date. All such insurance shall provide for compensation to be payable in the types and proportions of currencies required to rectify the loss or damage incurred.

12.3. Alterations to the terms of insurance shall not be made without the approval of the Engineer.

12.4. Both parties shall comply with any conditions of the insurance policies.

12.5. If the Contractor does not provide any of the policies and certificates required, the Employer may affect the insurance which the Contractor should have provided and recover the premiums the Employer has paid, from payments otherwise due to the Contractor or if no payment is due, the payment of premiums shall be debt due.

13. Site Investigation Report

The Contractor, in preparing the Bid, may rely, at his own risk, on any Site Investigation Reports referred to in the Contract Data, supplemented by any other information available to him, before submitting the bid.

14. Queries about the Contract Data

The Engineer will clarify queries on the Contract Data.

15. Contractor to Construct the Works and Undertake Maintenance (if specified in the tender)

15.1. The Contractor shall construct, and install and maintain the Works in accordance with the Specifications and Drawings and as per instructions of the Engineer.

15.2. The Contractor shall construct the works with intermediate technology, i.e., by manual means with medium input of machinery required to ensure the quality of

works as per specifications. The Contractor shall deploy the equipment and machinery as required in the contract.

15.3. The Contractor shall take all reasonable steps to protect the environment on and off the Site and to avoid damage or nuisance to persons or to property of the public or others resulting from pollution, noise or other causes arising as a consequence of his methods of operation. During continuance of the contract, the Contractor and his sub-contractors shall abide at all times by all existing enactments on environmental protection and rules made there under, regulations, notifications and byelaws of the State or Central Government, or local authorities and any other law, bye-law, regulations that may be passed or notification that may be issued in future by the State or Central Government or the local authority. Salient features of some of the major laws that are applicable are given below:

- The Water (Prevention and Control of Pollution) Act, 1974, this provides for the prevention and control of water pollution and the maintaining and restoring of wholesomeness of water. 'Pollution' means such contamination of water or such alteration of the physical, chemical or biological properties of water or such discharge of any sewage or trade effluent or of any other liquid, gaseous or solid substance into water (whether directly or indirectly) as may, or is likely to, create a nuisance or render such water harmful or injurious to public health or safety, or to domestic, commercial, industrial, agricultural or other legitimate uses, or to the life and health of animals or plants or of aquatic organisms.
- The Air (Prevention and Control of Pollution) Act, 1981, this provides for prevention, control and abatement of air pollution. 'Air Pollution' means the presence in the atmosphere of any 'air pollutant', which means any solid, liquid or gaseous substance (including noise) present in the atmosphere in such concentration as may be or tend to be injurious to human beings or other living creatures or plants or property or environment.
- The Environment (Protection) Act, 1986, this provides for the protection and improvement of environment and for matters connected therewith, and the prevention of hazards to human beings, other living creatures, plants and property. 'Environment' includes water, air and land and the interrelationship which

exists among and between water, air and land, and human beings, other living creatures, plants, micro-organism and property.

- The Public Liability Insurance Act, 1991, This provides for public liability insurance for the purpose of providing immediate relief to the persons affected by accident occurring while handling hazardous substances and for matters connected herewith or incidental thereto. Hazardous substance means any substance or preparation which is defined as hazardous substance under the Environment (Protection) Act 1986, and exceeding such quantity as may be specified by notification by the Central Government.

16. The Works and Routine Maintenance to be completed by the Intended Completion Date

The Contractor may commence execution of the Works on the Start Date and shall carry out the Works and Routine Maintenance, if specified in the tender, in accordance with the Programme submitted by the Contractor, as updated with the approval of the Engineer, and complete them by the Intended Completion Date.

17. Approval by the Engineer

- 17.1. The Contractor shall submit Specifications and Drawings showing the proposed Temporary Works to the Engineer, who is to approve them if they comply with the Specifications and Drawings.
- 17.2. The Contractor shall be responsible for design and safety of Temporary Works.
- 17.3. The Engineer's approval shall not alter the Contractor's responsibility for design and safety of the Temporary Works.
- 17.4. The Contractor shall obtain approval of third parties to the design of the Temporary Works, where required.
- 17.5. All Drawings prepared by the Contractor for the execution of the temporary or permanent Works, are subject to prior approval by the Engineer before their use.

18. Safety

- 18.1. The Contractor shall be responsible for the safety of all activities on the Site. He shall comply with all applicable safety requirements and take care of safety of all persons

entitled to be on the site and the works. He shall use reasonable efforts to keep the site and the works, both during construction and maintenance, clear of unnecessary obstruction so as to avoid danger to the persons and the users.

- i. Workers employed on mixing asphaltic materials, cement and lime mortars shall be provided with protective footwear and protective goggles.
- ii. Stone breaker shall be provided with protective goggles and protective clothing and seated at sufficiently safe intervals.
- iii. The area should be barricaded or cordoned off by suitable means to avoid mishaps of any kind. Power warning signs should be displayed for the safety of the public whenever cleaning works are undertaken during night or day.
- iv. The workers engaged for cleaning the manholes/sewers should be properly trained before allowing working in the manhole.

18.2. Safety Programs: -

- i. Have adequate safety supervision in place to ensure that safety programs set up by the firms/agencies are in compliance with prevalent laws and regulations.
- ii. Review safety programs developed by each of the trade firms, prepare and submit a comprehensive safety program.
- iii. Monitor day to day implementation of safety procedures.

18.3. First Aid Facilities: -

- i. At every work place there shall be provided and maintained, so as to be easily accessible during working hours, first-aid boxes at the rate of not less than one box for 150 contract labour or part thereof ordinarily employed.
- ii. The first-aid box shall be distinctly marked with a red cross on white background.
- iii. Adequate arrangements shall be made for immediate recoupment of the equipment when necessary.
- iv. Nothing except the prescribed contents shall be kept in the First-aid box.
- v. The first-aid box shall be kept in charge of a responsible person who shall always be readily available during the working hours of the work place.

- vi. A person in charge of the First-aid box shall be a person trained in First-aid treatment, in the work places where the number of contract labour employed is 150 or more.

19. Discoveries

Anything of historical or other interest or of significant value unexpectedly discovered on the Site shall be the property of the Employer. The Contractor shall notify the Engineer of such discoveries and carry out the Engineer's instructions for dealing with them.

20. Possession of the Site

The Employer shall handover complete or part possession of the site to the Contractor 7 days in advance of construction programme. At the start of the work, the Employer shall handover the possession of at-least 75% of the site free of all encumbrances, the remaining 25% of the possession as per contractor's construction programme.

21. Access to the Site

The Contractor shall allow access to the Site and to any place where work in connection with the Contract is being carried out, or is intended to be carried out to the Engineer and any person/persons/agency authorized by: a. The Engineer b. The Employer or authorized by the Employer.

22. Instructions

22.1. The Contractor shall carry out all instructions of the Engineer, which comply with the applicable laws where the Site is located.

22.2. The Contractor shall permit the appointed and/or authorized persons to inspect the Site and/or accounts and records of the Contractor and its subcontractors relating to the performance of the Contract, and to have such accounts and records audited by auditors appointed, if so required. The Contractor's attention is invited to Clause of 'Fraud and Corruption', which provides, inter alia, that acts intended to materially impede the exercise of the inspection and audit rights provided for under the Clause & constitute a obstructive practice subject to contract termination

22.3. Engineer to have power to issue further drawings or instructions:

The Engineer shall have the power and authority from time to time and at all times to make an issue such further drawings and to give such further instructions and directions as may appear to him necessary or proper for the guidance of the contractor and the good and sufficient execution of the works according to terms of the specifications and Contractor shall receive, execute, obey and be bound by the same, according to the true intent and meaning thereof, as fully and effectually as though the same had accompanied or had been mentioned or referred to in the specification, and the Engineer may also alter or vary the levels or position of nature of works contemplated by the specifications, or may order any of the works contemplated thereby to be omitted, with or without the substitution of any other works in lieu thereof, or may order any work or any portion of work executed or partially executed, to be removed, changed or altered, added if needful, may order that other works shall be substituted instead thereof and difference of expense occasioned by any such diminution or alteration so ordered and directed shall be added to or deducted from the amount of this Contract, as provided under condition no.10(a) hereinafter.

No work which radically changes the original nature of the Contract shall be ordered by the Engineer and in the event of any deviation being ordered which in the opinion of the Contractor changes the original nature of Contract he shall nevertheless carry it out and disagreement as to the nature of the work and the rate to be paid therefore shall be resolved in accordance with condition no.13d.

The time for completion of the Works, shall be in even of any deviations resulting in additional cost over the contract price being ordered, be extended or reduced reasonably by the Engineer. The Engineer's decision in this case shall be final.

B. Time Control

23. Programme

23.1. Within the time stated in the Contract Data, the Contractor shall submit to the Engineer for approval a Programme, including Environment Management Plan showing the general methods, arrangements, order, and timing for all the activities in the Works, along with monthly cash flow forecasts for the construction of works.

After the completion of the construction works, the programme for the Routine Maintenance Work, showing the general methods, arrangements, order and timing for all the activities involved in the Routine Maintenance will also be submitted by the Contractor to the Engineer for approval if specified in the tender. The programme for Routine Maintenance will be submitted in each year for the period of Maintenance.

23.2. The Contractor shall submit the list of equipment and machinery being brought to site, the list of key personnel being deployed, the list of machinery/ equipments being placed in field laboratory and the location of field laboratory along with the Programme. The Engineer shall cause these details to be verified at each appropriate stage of the programme.

23.3. An update of the Programme shall be a programme showing the actual progress achieved on each activity and the effect of the progress achieved on the timing of the remaining Works, including any changes to the sequence of the activities.

23.4. The Contractor shall submit to the Engineer for approval an updated Programme at intervals no longer than the period stated in the Contract Data. If the Contractor does not submit an updated Programme within this period, the Engineer may withhold the amount stated in the Contract Data from the next payment certificate and continue to withhold this amount until the next payment after the date on which the overdue Programme has been submitted.

23.5. The Engineer's approval of the Programme shall not alter the Contractor's obligations. The Contractor may revise the Programme and submit it to the Engineer again at any time. A revised Programme shall show the effect of Variations and Compensation Events.

24. **Extension Of Time In Contracts**

Subject to any requirement in the contract as to completion of any portions or portions of the works before completion of the whole, the contractor shall fully and finally complete the whole of the works comprised in the contract (with such modifications as may be directed under conditions of this contract) by the date entered in the contract or extended date in terms of the following clauses:

a. **Extension attributable to BMC:**

- i. **Extension Due To Modification:** If any modifications have been ordered which in the opinion of the Engineer have materially increased the magnitude of the work, then such extension of the contracted date of completion may be granted as shall appear to the Engineer to be reasonable in the circumstances, provided moreover that the Contractor shall be responsible for requesting such extension of the date as may be considered necessary as soon as the cause thereof shall arise and in any case **should not be less than 30 days before the expiry of the date fixed for completion of the works.**
- ii. **Extension For Delay Due To BMC:** In the event of any failure or delay by the BMC to hand over the Contractor possession of the lands necessary for the execution of the works or to give the necessary notice to commence the works or to provide the necessary drawings or instructions or any other delay caused by the BMC due to any other cause whatsoever, then such failure or delay shall in no way affect or vitiate the contract or alter the character thereof or entitle the contractor to damages or compensation therefore, but in any such case, the BMC may grant such extension(s) of the completion date as may be considered reasonable.

Note: For extension of time period as governed in (i) and (ii) above, any modifications in design/drawings, specifications, quantities shall be needed to be justified with recorded reasons with approval of Ch.Eng. for not anticipating the same while preparing estimates and draft tender.

b. **Extension Of Time for Delay Due To Contractor:**

The time for the execution of the work or part of the works specified in the contract documents shall be deemed to be the essence of the contract and the works must be completed no later than the date(s) / the programme for completion of work as specified in the contract. If the contractor fails to complete the works within the time as specified in the contract for the reasons other than the reasons specified in above as (a.i) and (a.ii), the BMC may, if satisfied that the works can be completed by the contractor within reasonable short time thereafter, allow the contractor for further extension of time as the Engineer may decide. On such extension the BMC will be entitled without prejudice to any other right and remedy available on that behalf, to recover the compensation as governed by Clause 8(e) of GCC.

For the purpose of this Clause, the contract value of the works shall be taken as value of work as per contract agreement including any supplementary work order/contract agreement issued.

Further, competent authority while granting extension to the currency of contract under Clause (b) of as above may also consider levy of penalty, as deemed fit based on the merit of the case. Also, the reasons for granting extension shall be properly documented.

25. Delays Ordered by the Engineer

The Engineer may instruct the Contractor to delay the start or progress of any activity within the Works. Delay/delays totalling more than 30 days will require prior written approval of the DMC/AMC.

26. Management Meetings

26.1. The Engineer may require the Contractor to attend a management meeting. The business of a management meeting shall be to review the plans for progress of the Works.

26.2. The Engineer shall record the business of management meetings and provide copies of the record to those attending the meeting. The responsibility of the parties for actions to be taken shall be decided by the Engineer either at the management meeting or after the management meeting and stated in writing to all those who attended the meeting.

C. Quality Control (Not Applicable)

27.1. Work to be open to Inspection and Contractor or Responsible agent to be present

All works under or in course of execution or executed in pursuance of the contract shall at all times be open to the inspection and supervision of the Eng-in-charge and his subordinates and the contractor shall at all times during the usual working hours, at all other times, during the usual working hours and at all other times at which reasonable notice of the intention of the Eng-in-charge and his subordinates to visit the works shall have been given to the contractor, either himself be present to receive orders and instruction or have responsible agent duly accredited in writing present for that purpose. Order given to the contractors' duly authorized agent shall be considered to have the same force and effect as if they had been given to the contractor himself.

27.2. Notice To Be Given Before Work Is Covered Up

The contractor shall give to less than ten days' notice in writing to the Eng-In- Charge or his subordinate in-charge of the work before covering up or otherwise placing beyond the reach of measurement any work in order that the same may be measured and correct dimension thereof taken before the same is so covered up or placed beyond the reach of measurements and shall not cover up or place beyond the reach of measurement any work without the consent in writing of the Eng-In-Charge or his subordinate in-charge of the work, and if any work shall be covered up or placed beyond the reach of measurement, without such notice having been given or consent obtained the same shall be uncovered at the contractors expenses, and in default thereof no payment or allowance shall be made for such work or for the materials with which the same was executed.

27.3. Works to be executed in accordance with specifications / drawings /orders etc.:

The contractor shall execute the whole and every part of the work the most substantial and workman like manner and both has regarded material and every other respect in strict accordance with specifications. The contractor shall also confirm exactly, fully and faithfully to the designs, drawings and instructions in writing relating to the work signed by the Engineer In-charge and lodged in his office and to which the contractor shall be entitled to have access for the purpose of inspection

at such office, or on the site or work during office hours. The contractor shall be entitled to receive three sets of contract drawings and working drawings as well as one certified copy of the accepted tender along with the work order free of cost.

27.4. Ready Mix Concrete/ Asphalt Mix

- i. The contractor shall have to arrange Ready Mix concrete (RMC)/Asphalt from RMC/ASPHALT producing plants registered with BMC
- ii. The contractor shall, within 7 days of award of the work, submit a list of at least three RMC/Asphalt producers with details of such plants including details and number of transits, mixers & pumps etc. to be deployed indicating name of owner/company, its location, capacity, technical establishment.

The Engineer-in-charge will reserve right to inspect at any stage and reject the concrete if he is not satisfied about quality of product at the user's end.

- iii. The Engineer-in-charge reserves the right to exercise control over the: -
 - a. Calibration check of the RMC/Asphalt plant.
 - b. Weight and quantity check on the ingredients, water and admixtures added for batch mixing for RMC plants
 - c. Time of mixing of concrete/grade of asphalt.
 - d. Testing of fresh concrete/asphalt mix, recording of results and declaring the mix fit or unfit for use. This will include continuous control on the work ability during production and taking corrective action, if required.
 - e. For exercising such control, the Engineer-in-charge shall periodically depute his authorized representative at the RMC/Asphalt plant. It shall be responsibility of the contractor to ensure that all necessary equipment, manpower & facilities are made available to Engineer-in-charge and or his authorized representative at RMC/Asphalt plant.
 - f. All required relevant records of RMC/Asphalt mix shall be made available to the Engineer-in-charge or his authorized representative. Engineer-in-charge shall, as required, specify guidelines & additional procedures for quality control & other parameters in respect of material production & transportation

of concrete mix which shall be binding on the contractor & the RMC/Asphalt plant. Only concrete as approved in design mix by Engineer-in-charge shall be produced in RMC plant and transported to the site.

- g. The contractor shall have to produce a copy of challan receipts/SCADA reports/VTS reports as issued by the RMC/Asphalt plant as a documentary proof in lieu of supply of RMC/Asphalt mix before releasing payment.

28. Identifying Defects

28.1. The Engineer shall check the Contractor's work and notify the Contractor of any Defects that are found. Such checking shall not affect the Contractor's responsibilities. The Engineer may instruct the Contractor to search for a Defect and to uncover and test any work that the Engineer considers may have a Defect.

28.2. The Contractor shall permit the Employer's technical person(s) to check the Contractor's work and notify the Engineer and Contractor if any defects that are found.

29. Tests

29.1. For carrying out mandatory tests as prescribed in the specifications, the Contractor shall establish field laboratory at the location decided by Engineer. The field laboratory will have minimum of equipments as specified in the Contract Data. The contractor shall be solely responsible for:

- a. Carrying out the mandatory tests prescribed in the Specifications, and
- b. For the correctness of the test results, whether performed in his laboratory or elsewhere.

29.2. If the Engineer instructs the Contractor to carry out a test not specified in the Specification/ Quality Assurance Handbook to check whether any work has a Defect and the test shows that it does, the Contractor shall pay for the test and any samples. If there is no defect, the test shall be a compensation event.

When required by the Engineer-in-charge the contractor(s) shall supply for the purpose of testing samples of all materials proposed to be used in the works. Samples submitted either to govern bulk supplies or required for testing before use shall be in suitable packages to contain them and shall be provided free of charge by the

contractor. The cost of testing shall be borne by the contractor even if the result of the sample confirms or do not confirm to the relevant BIS code specifications.

- i. All expenditure required to be incurred for taking the samples conveyance, packing shall be borne by the contractor himself.
- ii. The failed material shall be removed from the site by the contractor at his own cost within a week time of written order of the Engineer-in-charge.

29.3. Setting of Site Laboratories:

Contractors shall set up a laboratory at site before commencement of work at their cost for performing various tests and at least the following machines and equipments shall be provided therein -

1. Set of Sieves as per I.R.C. /I.S.
2. Compressive Testing Machine (For new works)
3. Oven, Electrically Operated
4. Weighing Balance (20 kg capacity)
5. 3 m straight edge
6. Sieve shaker
7. First Aid Box
8. Measuring Jar (for silt content)
9. Other Machines/apparatus as may be directed by the Engineer
10. Vernier Calliper
11. Level / Theodolite

All the test records shall be maintained in the site office and made available as and when required. The laboratory must be established within 15 days from the date of receipt of the orders from Engineer In charge. On failure to do so, a penalty of Rs 1000/- per day shall be imposed.

The contractor shall install testing equipment at site. The contractor shall ensure and certify the calibration of the equipment so installed and shall maintain the same in

working order throughout the period of construction. The contractor shall also provide necessary technically qualified experienced trained staff for carrying out such tests for using such equipment. The tests shall be carried out under the supervision of the Engineer-in-charge. The calibration shall be checked every twelve months as directed by Engineer-in-charge.

30. Correction of Defects noticed during the Defects Liability Period.

- 30.1. The Engineer shall give notice to the Contractor of any Defects before the end of the Defects Liability Period, which begins at Completion and ends after five years. The Defects Liability Period shall be extended for as long as Defects remain to be corrected
- 30.2. Every time notice of Defect/Defects is given, the Contractor shall correct the notified Defect/Defects within the duration of time specified by the Engineer's notice.
- 30.3. The Engineer may issue notice to the Contractor to carry out removal of defects or deficiencies, if any, noticed in his inspection, or brought to his notice. The Contractor shall remove the defects and deficiencies within the period specified in the notice and submit to the Engineer a compliance report.

31. Uncorrected Defects and Deficiencies

If the Contractor has not corrected a Defect pertaining to the Defect Liability Period under clause and deficiencies in maintenance, to the satisfaction of the Engineer, within the time specified in the Engineer's notice, the Engineer will assess the cost of having the Defect or deficiency corrected, and the Contractor shall pay this amount, on correction of the Defect or deficiency by another agency.

D. Cost Control

32. Variations

The Engineer shall, having regard to the scope of the Works and the sanctioned estimated cost, have power to order, in writing, Variations within the scope of the Works he considers necessary or advisable during the progress of the Works. Such Variations shall form part of the Contract and the Contractor shall carry them out and include them in updated Programmes produced by the Contractor. Oral orders of the Engineer for Variations, unless followed by written confirmation, shall not be taken into account.

33. Payments for Variations

33.1. If rates for Variation items are specified in the Bill of Quantities, the Contractor shall carry out such work at the same rate.

33.2. The rate for Extra / Excess shall be governed As per Circular No. CA(F)/Project/31 Dt. 26/10/2020 as per Annexure -O.

34. Cash Flow Forecasts

When the Programme is updated, the Contractor shall provide the Engineer with an updated cash flow forecast.

35. Payment Certificates

The payment to the Contractor will be as follows for construction work:

- a. A bill shall be submitted by the Contractor monthly or before the date fixed by the Engineer In-charge for all works executed in the previous month, and the Engineer In-charge shall take or cause to be taken requisite measurement for the purpose of having the same verified and the claim, so far as it is admissible, shall be adjusted, if possible, within 10 days from the presentation of the bill. If the contractor does not submit the bill within the time fixed as aforesaid, the Engineer In-charge may depute a subordinate to measure up the said work in the presence of the contractor or his duly authorized agent whose counter signature to the measurement list shall be sufficient warrant, and Engineer In-Charge may prepare a bill from such list which shall be binding on the contractor in all respects.
- b. The Engineer shall check the Contractor's fortnightly/monthly statement within 14 days and certify the amount to be paid to the Contractor.
- c. The value of work executed shall be determined, based on measurements by the Engineer.
- d. The value of work executed shall comprise the value of the quantities of the items in the Bill of Quantities completed.
- e. The value of work executed shall also include the valuation of Variations and Compensation Events.

- f. The Engineer may exclude any item certified in a previous certificate or reduce the proportion of any item previously certified in any certificate in the light of later information.
- g. The contractor shall submit all bills on the printed forms at the office of Engineer In-charge. The charges to be made in the bills shall always be entered at the rates specified in tender.

36. Payments

- 36.1. Payments shall be adjusted for deductions for advance payments, retention, security deposit, other recoveries in terms of the Contract and taxes at source, as applicable under the law. The Employer shall pay the Contractor the amounts certified by the Engineer within 15 days of the date of each certificate.
- 36.2. All sums payable by a contractor by way of compensation under any of these conditions, shall be considered as a reasonable compensation to be applied to the use of BMC without reference to the actual loss or damage sustained and whether any damage has or has not been sustained.
- 36.3. No payment shall be made for any work estimated to cost less than Rupees One Thousand till after the whole of work shall have been completed and the certificate of completion given. But in the case of works estimated to cost more than Rs. One Thousand, the contractor shall on submitting a monthly bill therefore be entitled to receive payment proportionate to the part of the work than approved and passed by the Engineer In-charge, whose certificate of such approval and passing of the sum so payable shall be final and conclusive against the contractor. All such intermediate payments shall be regarded as payments by way of advance against the final payments only and not as payments for work actual done and completed and shall not preclude the Engineer In-charge from requiring any bad, unsound, imperfect or unskilful work to be removed or taken away and reconstructed or re-erected nor shall any such payment be considered as an admission of the due performance of the contract or any part thereof in any respect or the offering of any claim not shall it conclude, determine or effect in any other way, the powers of the Engineer In-charge as to the final settlement and adjustment of the accounts or otherwise, or in any other way vary or

effect the contract. The final bill shall be submitted by the Contractor within one month of the date fixed for the completion of the work otherwise the Engineer In-charge's certificate of the measurements and of the total amount payable for the work shall be final and binding on all parties.

37. The Contractor shall not be entitled to compensation to the extent that the Employer's interests are adversely affected by the Contractor for not having given early warning or not having cooperated with the Engineer.

38. Tax

The tenderer shall quote inclusive of all taxes other than GST (Excluding GST), Levies, Duties, Cess etc. as applicable at the time of bid submission. GST as applicable shall be paid separately on submission of bills/invoice.

Input Tax Credit of GST as available with the bidder will not be claim separately by BMC. However, while quoting the rates benefit of Input Tax Credit or Exemptions shall be passed on to the BMC by way of equivalent reduction in quoted price.

39. Currencies

All payments will be made in Indian Rupees.

40. Liquidated Damages

Both, the Contractor and the Employer have agreed that it is not feasible to precisely estimate the amount of losses due to delay in completion of works and the losses to the public and the economy, therefore, both the parties have agreed that the Contractor shall pay liquidated damages to the Employer and not by way of penalty, at the rate per week or part thereof stated in the Contract Data for the period that the Completion Date is later than the Intended Completion Date. Liquidated damages at the same rates shall be withheld if the Contractor fails to achieve the milestones prescribed in the Contract Data. However, in case the Contractor achieves the next milestone, the amount of the liquidated damages already withheld shall be restored to the Contractor by adjustment in the next payment certificate.

The Employer and the contractor have agreed that this is a reasonable agreed amount of liquidated damage. The Employer may deduct liquidated damages from payments due to the Contractor. Payment of liquidated damages shall not affect the Contractor's other liabilities.

41. Cost of Repairs

Loss or damage to the Works or Materials to be incorporated in the Works between the Start Date and the end of the Defects Correction periods shall be remedied by the Contractor at his cost if the loss or damage arises from the Contractor's acts or omissions.

E. Finishing the Contract

42. Completion of Construction and Maintenance

The Contractor shall request the Engineer to issue a certificate of completion of the construction of the works, and the Engineer will do so upon deciding that the works is completed. This shall be governed as per clause no.8 (g) of Standard General Conditions of Contract.

43. Taking Over

The Employer shall take over the works within seven days of the Engineer issuing a certificate of completion of works. The Contractor shall continue to remain responsible for its routine maintenance during the maintenance period if specified in the contract.

44. Final Account

Final joint measurement along with the representatives of the contractor should be taken recorded and signed by the Contractors. Contractors should submit the final bill within 1 month of physical completion of the work.

If the contractor fails to submit the final bill within 1 month, the BMC staff will prepare the final bill based on the joint measurement within next 3 months.

Engineer's decision shall be final in respect of claims for defect and pending claims against contractors.

No further claims should be made by the Contractor after submission of the final bill and these shall be deemed to have been waived and extinguished. Payment of those items of the bills in respect of which there is no dispute and of items in dispute, for quantities and rates as approved by the Commissioner shall be made within a reasonable period as may be necessary for the purpose of verification etc.

After payment of the final bill as aforesaid has been made, the contractor may, if he so desires, reconsider his position in respect of a disputed portion of the final bills and if he fails to do so within 84 days, his disputed claim shall be dealt with as provided in the contract.

A percentage of the retention money, over and above the actual retention money as indicated below shall be held back from payments till the finalization of final bill to be submitted as per above and will be paid within 30 days of acceptance of the final bill.

Sr.no.	Amount of Contract Cost	Minimum Payable Amount in final bill
1	Up to Rs.5 Crs.	Rs.10 Lacs or final bill whichever is more
2	Up to Rs.25 Crs.	Rs.1 Crore or final bill amount whichever is more
3	Up to Rs. 50 Crs.	Rs.2 Crores or final bill amount whichever is more
4	Up to Rs.100 Crs.	Rs.4 Crore or final bill amount whichever is more
5	More than Rs.100 Crs.	Rs.7 Crore or final bill amount whichever is more

The contractor has to submit the bill for the work carried out within 15 days from the date of completion of the work to the respective executing department. If the contractor fails to submit their bills to concerned executing department, penalty or action as shown below will be taken for each delayed bill: -

After 15 days from the date of completion/running bill up to certain date, up to next 15 days i.e. up to 30 days	Equal to 5% of bill amount
Next 15 days up to 45 days from the date of completion/running bill up to specified date	Equal to 10% of bill amount
If not submitted within 45 days from the date of completion/ R.A. bill	Bill will not be admitted for payment

45. Operating and Maintenance Manuals

45.1. If "as built" Drawings and/or operating and maintenance manuals are required, the Contractor shall supply them by the dates stated in the Contract Data.

45.2. If the Contractor does not supply the Drawings and/or manuals by the dates stated in the Contract Data, or they do not receive the Engineer's approval, the Engineer shall withhold the amount stated in the Contract Data from payments due to the Contractor.

46. Termination

46.1. The Employer or the Contractor may terminate the Contract if the other party causes a fundamental breach of the Contract.

46.2. Fundamental breaches of Contract shall include, but shall not be limited to, the following:

- a. the Contractor stops work for 30 days when no stoppage of work is shown on the current Programme and the stoppage has not been authorized by the Engineer;
- b. the Contractor is declared as bankrupt or goes into liquidation other than for approved reconstruction or amalgamation;
- c. the Engineer gives Notice that failure to correct a particular Defect is a fundamental breach of Contract and the Contractor fails to correct it within a reasonable period of time determined by the Engineer;
- d. the Contractor does not maintain a Security, which is required;

- e. The Contractor has delayed the completion of the Works by the number of days for which the maximum amount of liquidated damages can be paid, as defined in relevant clause.
- f. The Contractor fails to provide insurance cover as required under relevant clause.
- g. If the Contractor, in the judgment of the Employer, has engaged in the corrupt or fraudulent practices as defined in GCC in competing for or in executing the Contract.
- h. if the Contractor fails to set up a field laboratory with the prescribed equipment, within the period specified in the Contract Data; and
- i. Any other fundamental breaches as specified in the Contract Data.
- j. If the Contractor fails to deploy machinery and equipment or personnel as specified in the Contract Data at the appropriate time.

46.3. When either party to the contract gives notice of a breach of contract to the Engineer for a cause other than those listed above, the Engineer shall decide whether the breach is fundamental or not.

46.4. Notwithstanding the above, the Employer may terminate the Contract for convenience.

46.5. If the Contract is terminated, the Contractor shall stop work immediately, make the Site safe and secure, and leave the Site as soon as reasonably possible.

47. Payment upon Termination

47.1. If the Contract is terminated because of a fundamental breach of Contract by the Contractor, the Engineer shall issue a certificate for value of the work done and materials ordered less liquidated damages, if any, less advance payments received up to the date of the issue of the certificate and less the percentage to apply to the value of the work not completed, as indicated in the Contract Data. If the total amount due to the Employer exceeds any payment due to the Contractor, the difference shall be recovered from the security deposit, and performance security. If any amount is still left un-recovered it will be a debt due from the Contractor to the Employer

47.2. If the Contract is terminated at the Employer's convenience, the Engineer shall issue a certificate for the value of the work done, the reasonable cost of removal of Equipment, repatriation of the Contractor's personnel employed solely on the Works, and the Contractor's costs of protecting and securing the Works and less advance payments received up to the date of the certificate, less other recoveries due in terms of the Contract, and less taxes due to be deducted at source as per applicable law.

48. Property

All Materials on the Site, Plant, Equipment, Temporary Works, and Works shall be deemed to be the property of the Employer for use for completing balance construction work if the Contract is terminated because of the Contractor's default, till the Works is completed after which it will be transferred to the Contractor and credit, if any, given for its use.

49. Release from Performance

If the Contract is frustrated by the outbreak of war or by any other event entirely outside the control of the Employer or the Contractor, the Engineer shall certify that the Contract has been frustrated. The Contractor shall make the Site safe and stop work as quickly as possible after receiving this certificate and shall be paid for all work carried out before receiving it and for any work carried out afterwards to which a commitment was made.

A) Other Conditions of Contract

50. Labour

50.1. The Contractor shall, unless otherwise provided in the Contract, make his own arrangements for the engagement of all staff and labour, local or other, and for their payment, housing, feeding and transport.

50.2. The Contractor shall, if required by the Engineer, deliver to the Engineer a return in detail, in such form and at such intervals as the Engineer may prescribe, showing the staff and the number of the several classes of labour from time to time employed by the Contractor on the Site and such other information as the Engineer may require.

51. Compliance with Labour Regulations

- a. During continuance of the Contract, the Contractor and his sub-Contractors shall abide at all times by all existing labour enactments and rules made there under, regulations, notifications and bye laws of the State or Central Government or local authority and any other labour law (including rules), regulations, bye laws that may be passed or notification that may be issued under any labour law in future either by the State or the Central Government or the local authority.
- b. Furthermore, the Contractor shall keep the Employer indemnified in case any action is taken against the Employer by the competent authority on account of contravention of any of the provisions of any Act or rules made there under, regulations or notifications including amendments. If the Employer is caused to pay or reimburse, such amounts as may be necessary to cause or observe, or for non-observance of the provisions stipulated in the notifications/bye laws/Acts/Rules/regulations including amendments, if any, on the part of the Contractor, the Engineer/Employer shall have the right to deduct any money due to the Contractor including his amount of performance guarantee. The Employer/Engineer shall also have right to recover from the Contractor any sum required or estimated to be required for making good the loss or damage suffered by the Employer.
- c. The Contractor shall require his employees to obey all applicable laws, including those concerning safety at work.
- d. The employees of the Contractor and the Sub-Contractor in no case shall be treated as the employees of the Employer at any point of time.

52. Drawings and Photographs of the Works

- 52.1. The Contractor shall do photography/video photography of the site firstly before the start of the work, secondly mid-way in the execution of different stages of work as required by Engineer In-charge and lastly after the completion of the work. No separate payment will be made to the Contractor for this.
- 52.2. The Contractor shall not disclose details of Drawings furnished to him and works on which he is engaged without the prior approval of the Engineer in writing. No

photograph of the works or any part thereof or plant employed thereon, except those permitted under above clause, shall be taken or permitted by the Contractor to be taken by any of his employees or any employees of his sub-Contractors without the prior approval of the Engineer in writing. No photographs/ Video photography shall be published or otherwise circulated without the approval of the Engineer in writing.

53. The Apprentices Act, 1961

The Contractor shall duly comply with the provisions of the Apprentices Act 1961 (Ill of 1961), the rules made there under and the orders that may be issued from time to time under the said Act and the said Rules and on his failure or neglect to do so, he shall be subject to all liabilities and penalties provided by the said Act and said Rules.

54. Contract Document

The documents forming the contract are to be taken as mutually explanatory of one another. Unless otherwise provided in the contract, the priority of the documents forming the contract shall be, as follows:

1. Contract Agreement (if completed)
2. The letter of Acceptance
3. The Bid:
4. Addendum to Bid; if any
5. Tender Document
6. The Bill of Quantities:
7. The Specification:
8. Detailed Engineering Drawings
9. Standard General Conditions of Contracts (GCC)
10. All correspondence documents between bidder/contractor and BMC.

55. Conflict of Interest

The Applicant shall not have a conflict of interest (the "Conflict of Interest") that affects the Bidding Process. Any Applicant found to have a Conflict of Interest shall be

disqualified. An Applicant shall be deemed to have a Conflict of Interest affecting the Bidding Process, if

1. A constituent of such Applicant is also a constituent of another Applicant; or
2. Such Applicant has the same legal representative for purposes of this Application as any other Applicant; or
3. Such Applicant, or any Associate thereof has a relationship with another Applicant, or any Associate thereof, directly or through common third party/ parties, that puts either or both of them in a position to have access to each other's information about, or to influence the Application of either or each other; or
4. The Applicant shall be liable for disqualification if any legal, financial or technical adviser of the Authority in relation to the Project is engaged by the Applicant, its Member or any Associate thereof, as the case may be, in any manner for matters related to or incidental to the Project. For the avoidance of doubt, this disqualification shall not apply where such adviser was engaged by the Applicant, its Member or Associate in the past but its assignment expired or was terminated 6 (six) months prior to the date of issue of this TENDER. Nor will this disqualification apply where such adviser is engaged after a period of 3 (three) years from the date of commercial operation of the Project.

56. Applications and costs thereof

No Applicant shall submit more than one Application for the Project. An applicant applying individually shall not be entitled to submit another application either individually. The Applicant shall be responsible for all of the costs associated with the preparation of their Applications and their participation in the Bid Process. The Authority will not be responsible or in any way liable for such costs, regardless of the conduct or outcome of the Bidding Process.

57. Acknowledgment by Applicant

It shall be deemed that by submitting the Application, the Applicant has:

- a. made a complete and careful examination of the tender;
- b. received all relevant information requested from the Authority;

- c. accepted the risk of inadequacy, error or mistake in the information provided in the tender or furnished by or on behalf of the Authority relating to any of the matters referred; and
- d. Agreed to be bound by the undertakings provided by it under and in terms hereof.

“The Authority” shall not be liable for any omission, mistake or error in respect of any of the above or on account of any matter or thing arising out of or concerning or relating to the TENDER or the Bidding Process, including any error or mistake therein or in any information or data given by the Authority.

58. Right to accept or reject any or all Applications / Bids

Notwithstanding anything contained in this TENDER, “The Authority” reserves the right to accept or reject any Application and to annul the Bidding Process and reject all Applications/ Bids, at any time without any liability or any obligation for such acceptance, rejection or annulment, and without assigning any reasons therefore. In the event that the Authority rejects or annuls all the Bids, it may, in its discretion, invite all eligible Bidders to submit fresh Bids hereunder.

“The Authority” reserves the right to reject any Application and/ or bid if:

- a. at any time, a material misrepresentation is made or uncovered, or
- b. The Applicant does not provide, within the time specified by the Authority, the supplemental information sought by the Authority for evaluation of the Application.

In case it is found during the evaluation or at any time before signing of the Agreement or after its execution and during the period of subsistence thereof including the concession thereby granted by “The Authority”, that one or more of the pre-qualification conditions have not been met by the Applicant, or the Applicant has made material misrepresentation or has given any materially incorrect or false information, the Applicant shall be disqualified forthwith if not yet appointed as the Successful Bidder either by issue of the LOA (Letter of Approval) or entering into of the Agreement, and if the Applicant has already been issued the LOA or has entered into the Concession Agreement, as the case may be, the same shall, notwithstanding anything to the contrary contained therein or in this TENDER, be liable to be terminated, by a communication in writing by “The Authority” to the

Applicant, without the Authority being liable in any manner whatsoever to the Applicant and without prejudice to any other right or remedy which the Authority may have under this TENDER, the Bidding Documents, the Concession Agreement or under applicable law.

“The Authority” reserves the right to verify all statements, information and documents submitted by the Applicant in response to the TENDER. Any such verification or lack of such verification by the Authority shall not relieve the Applicant of its obligations or liabilities hereunder nor will it affect any rights of the Authority there under.

59. The bid shall be rejected if the bidder-

- a. Stipulates the validity period less than 180 days.
- b. Stipulates own condition/conditions.
- c. Does not fill and (digital) sign undertaking forms, which are incorporated, in the document.

60. Clarifications

Applicants requiring any clarification on the tender may notify “the Authority” in writing or by fax or e-mail. They should send in their queries before the date specified in the header data. “The Authority” shall Endeavour to respond to the queries within the period specified therein. The responses will be sent by fax and/or e-mail. The Authority will forward all the queries and its responses thereto, to all purchasers of the TENDER without identifying the source of queries.

“The Authority” shall Endeavour to respond to the questions raised or clarifications sought by the Applicants. However, the Authority reserves the right not to respond to any question or provide any clarification, in its sole discretion, and nothing in this Clause shall be taken or read as compelling or requiring the Authority to respond to any question or to provide any clarification, but not later than the date provided in header data.

“The Authority” may also on its own motion, if deemed necessary, issue interpretations and clarifications to all Applicants. All clarifications and interpretations issued by the Authority shall be deemed to be part of the tender. Verbal clarifications

and information given by Authority or its employees or representatives shall not in any way or manner be binding on the Authority.

61. Amendment of tender

At any time prior to the deadline for submission of Application, the Authority may, for any reason, whether at its own initiative or in response to clarifications requested by an Applicant, modify the tender by the issuance of Addendum.

Any Addendum thus issued will be sent in writing/ Fax/ Email to all those who have purchased the tender.

In order to afford the Applicants a reasonable time for taking an Addendum into account, or for any other reason, the Authority may, in its sole discretion, extend the Application Due Date.

Preparation and Submission of Application

62. Language

The Application and all related correspondence and documents in relation to the Bidding Process shall be in English language. Supporting documents and printed literature furnished by the Applicant with the Application may be in any other language provided that they are accompanied by translations of all the pertinent passages in the English language, duly authenticated and certified by the Applicant. Supporting materials, which are not translated into English, may not be considered. For the purpose of interpretation and evaluation of the Application, the English language translation shall prevail.

63. Format and signing of Application

The Applicant shall provide all the information sought under this TENDER. The Authority will evaluate only those Applications that are received in the required formats and complete in all respects. Incomplete and /or conditional Applications shall be liable to rejection.

The Applicant will upload bid in One Folder in electronic form which shall contain the scanned certified copies of the documents given below and the documents uploaded has to be digitally signed by the bidder. These copies shall be certified

by Practicing Notary approved by the Govt. of Maharashtra or Govt. of India with his stamp, clearly stating his name & registration number, except where original documents are demanded

64. Marking of Applications

The Applicant shall submit the Application in the format specified at Appendix-I, together with the documents, upload in folder as "VENDOR" together with their respective enclosures.

Applications submitted by fax, telex, telegram shall not be entertained and shall be rejected outright

65. Late Applications

Applications received by the Authority after the specified time on the Application Due Date shall not be eligible for consideration and shall be summarily rejected.

66. Confidentiality

Information relating to the examination, clarification, evaluation, and recommendation for the short-listed qualified Applicants shall not be disclosed to any person who is not officially concerned with the process or is not a retained professional advisor advising the Authority in relation to or matters arising out of, or concerning the Bidding Process. The Authority will treat all information, submitted as part of Application, in confidence and will require all those who have access to such material to treat the same in confidence. The Authority may not divulge any such information unless it is directed to do so by any statutory entity that has the power under law to require its disclosure or is to enforce or assert any right or privilege of the statutory entity and/ or the Authority or as may be required by law or in connection with any legal process.

67. Clarification Of Financial Bids

To assist in the examination, evaluation and comparison of Bids, the Engineer may, at his discretion, ask any bidder for clarification of his Bid, including breakdown of unit rates. The request for clarification and the response shall be in writing or by post/facsimile/e-mail. No Bidder shall contact the Engineer on any matter relating to

his bid from the time of the bid opening to the time the contract is awarded. Any effort by the Bidder to influence the Engineer in the Engineer's bid evaluation, bid comparison or contract award decisions may result in the rejection of the Bidder's bid.

68. Inspection of site and sufficiency of tender:

1. The Contractor shall inspect and examine the site and its surrounding and shall satisfy himself before submitting his tender as to the nature of the ground and subsoil (so far as is practicable), the form and nature of the site, the quantities and nature of the work and materials necessary for the completion of the works and means of access to the site, the accommodation he may require and in general shall himself obtain all necessary information as to risk, contingencies and other circumstances which may influence or affect his tender. He shall also take into consideration the hydrological and climatic conditions.
2. The Employer may make available to the Contractor data on hydrological and sub-surface conditions as obtained by or on his behalf from investigations relevant to the works but the Contractor shall be responsible for his own interpretation thereof. The contractor shall engage his investigating agency with prior approval of the Engineer from the approved list of such agencies by BMC or Govt. at his cost initially before commencing actual work and which shall be reimbursed immediately subject to satisfaction of the Engineer for faithful compliance and submission of required data regarding such investigation within specified time.
3. The Contractor shall be deemed to have satisfied himself before tendering as to the correctness and sufficiency of his tender for the works and of the rates and prices quoted in the schedule of works / items / quantities, or in Bill of Quantities, which rates and prices shall, except as otherwise provided cover all his obligations under the Contract and all matters and things necessary for proper completion and maintenance of the works. No extra charges consequent on any misunderstanding.
4. **Not Foreseeable Physical Obstructions or Conditions:** If, however, during the execution of the Works the Contractor encounters physical obstructions or physical conditions, other than climatic conditions on the Site, which obstructions or conditions were, in his opinion, not foreseeable by an experienced contractor, the Contractor shall

forthwith give notice thereof to the Engineer. On receipt of such notice, the Engineer shall, if in his opinion such obstructions or conditions could not have been reasonably foreseen by an experienced contractor, after due consultation with the Contractor, determine:

- any extension of time to which the Contractor is entitled and
- The amount of any costs which may have been incurred by the Contractor by reason of such obstructions or conditions having been encountered, which shall be added to the Contract Price, and shall notify the Contractor accordingly.
- Such determination shall take account of any instruction which the Engineer may issue to the Contractor in connection therewith, and any proper and reasonable measures acceptable to the Engineer which the Contractor may take in the absence of specific instructions from the Engineer. However, such costing shall be got approved by the competent authority as governed vide rules prevailing with authority.

5. **Office for the Engineer (Works costing upto Rs.50 lakhs)**

The contractor shall at his own cost and to satisfaction of the Engineer provide a small temporary office, at the work-site which will include tables, chairs and lockers for keeping the records. He shall also make necessary arrangements for drinking water, telephone with a pre-requisite of e-governance and electronic communication. These offices are not to be allowed on public roads without the written instruction of the Engineer. These offices should be preferably located within 50 to 500 m of the worksite. In case the office is more than 500m away from the worksite, the contractor is to provide conveyance for Municipal Staff.

6. **Office for the Engineer (Works costing above Rs.50 lakhs)**

The Contractor shall at his own cost and to satisfaction of the Engineer provide a temporary office at the work-site which will include tables, chairs and lockers for keeping the records. He shall also make necessary arrangements for drinking water, latrines, with doors, windows, locks, bolts and fastenings sufficient for security for the Engineer, and his subordinates, as close to the works from time to time in progress as can be conveniently arranged, and shall at his own cost furnish the office with such

chairs, tables, lockers, locks and fastenings as may be required by the Engineer, and no expense of any kind in connection with the erection or upkeep of the offices or fittings shall be borne by the Corporation, but all such work shall be carried out by the Contractor and the expenses thereof defrayed by him. The Contractor shall also make water connections and fit up stand pipe with a bib tap at each office. The latrines and the water connections shall be subject to all the conditions herein elsewhere laid down for temporary water connection and latrines generally with all requisite equipments for e-governance and electronic and digital communication. These offices are not to be allowed on public roads without the written instruction of the Engineer. These offices should be preferably located within 50 to 500 m of the worksite. ~~In case the office is more than 500m away from the worksite, the contractor is to provide conveyance. Also, for staff working beyond working hours the contractor has to provide conveyance.~~

7. Permission for provision and removal of office on completion of work:

The tenderer shall obtain permission for provision of site office, cement go-down, store, etc. on payment of necessary cost implication. The cement go-down, Watchman cabins, etc. shall be provided as directed and shall be removed by the Tenderers on completion of the work at their cost. It is binding on the Tenderer to fulfill requirements of Environmental Authorities. The location of such office shall be finalized and got approved from the Engineer before erection/commencement work.

- 8. Contractor's office near works:** The Contractor shall have an office near the works at which notice from the Commissioner or the Engineer may be served and shall, between the hours of sunrise and sunset on all working days, have a clerk or some other authorized person always present at such office upon whom such notices may be served and service of any notices left with such clerk or other authorized person or at such office shall be deemed good service upon the Contractor and such offices shall have pre-requisite facilities for e-governance.

69. Official Secrecy:

The Contractor shall of all the persons employed in any works in connection with the contract that the India Official Secrets Act 1923 (XIX of 1923) applies to them and

will continue to apply even after execution of the said works and they will not disclose any information regarding this contract to any third party. The contractor shall also bring into notice that, any information found to be leaked out or disclosed the concern person as well as the Contractor will be liable for penal action; further the Corporation will be at liberty to terminate the contract without notice.

70. Subsequent Legislation:

If on the day of submission of bids for the contract, there occur changes to any National or State statute, Ordinance, decree or other law or any regulation or By-laws or any local or other duly constituted authority or the introduction of any such National or State Statute, Ordinance, decree or by which causes additional or reduced cost to the Contractor, such additional or reduced cost shall, after due consultation with the Contractor, be determined by the concerned Engineering Department of BMC and shall be added to or deducted from the Contract Price with prior approval of competent authority and the concerned Engineering Department shall notify the Contractor accordingly with a copy to the Employer. BMC reserve the right to take decision in respect of addition/reduction of cost in contract.

71. Patent, Right and Royalties:

The contractor shall save harmless and indemnify the Corporation from and against all claims and proceedings for or on account of infringement of any Patent rights, design trademark or name of other protected rights in respect of any constructional plant, machine work, or material used for or in connection with the Works or any of them and from and against all claims, proceedings, damages, costs, charges and expenses whatsoever in respect thereof or in relation thereto. Except where otherwise specified, the contractor shall pay all tonnage and other royalties, rent and other payments or compensation, if any, for getting stone, sand, gravel, clay or other materials required for the works or any of them.

72. Payments, Tax and Claims:

- **The limit for unforeseen claims**

Under no circumstances whatever the contractor shall be entitled to any compensation from BMC on any account unless the contractor shall have submitted a claim in writing to the Eng-in-charge within 1 month of the case of such claim occurring.

- **No interest for delayed payments due to disputes, etc:**

It is agreed that the Municipal Corporation of Greater Mumbai or its Engineer or Officer shall not be liable to pay any interest or damage with respect of any moneys or balance which may be in its or its Engineer's or officer's hands owing to any dispute or difference or claim or misunderstanding between the Municipal Corporation of Greater Bombay or its Engineer or Officer on the one hand and the contractor on the other, or with respect to any delay on the part of the Municipal Corporation of Greater Bombay or its Engineer or Officers in making periodical or final payments or in any other respect whatever.

73. Settlement of Disputes:

- **Termination of contract for death**

If the Contractor is an individual or a proprietary concern and the individual or the proprietor dies and if the Contractor is a partnership concern and one of the legal representative of the individual Contractor or the proprietor of the proprietary concern and in case of partnership, the surviving partners, are capable of carrying out and completing the contract, the Commissioner shall be entitled to cancel the contract as to its uncompleted part without the Corporation being in any way liable to payment of any compensation to the estate of the deceased Contractor and or to the surviving partners of the Contractor's firm on account of the cancellation of the contract. The decision of the Commissioner that the legal representative of the deceased Contractor or surviving partners of the Contractor's firm cannot carry out and complete the contract shall be final and binding on the parties. In the event of such cancellation the Commissioner shall not hold estate of

the deceased Contractor and or surviving partners of the Contractor's firm liable in damages for not completing the contract.

- **Settlement of Disputes:**

If any dispute or differences of any kind whatsoever other than those in respect of which, the decision of any person is, by the Contract, expressed to be final and binding) shall arise between the Employer and the Contractor or the Engineer and the Contractor in connection with or arising out of the Contract or carrying out of the Works (Whether during the progress of the Works or after their completion and whether before or after the termination, abandonment or breach of the Contract) it, the aggrieved party may refer such dispute within a period of 7 days to the concerned Addl. Municipal Commissioner who shall constitute a committee comprising of three officers i.e. concerned Deputy Municipal Commissioner or Director (ES&P), Chief Engineer other than the Engineer of the Contract and concerned Chief Accountant. The Committee shall give decision in writing within 60 days. Appeal on the Order of the Committee may be referred to the Municipal Commissioner within 7 days. Thereafter the Municipal Commissioner shall constitute a Committee comprising of three Addl. Municipal Commissioners including Addl. Municipal Commissioner in charge of Finance Department. The Municipal Commissioner within a period of 90 days after being requested to do so shall give written notice of committee's decision to the Contractor. Save as herein provided such decision in respect of every matter so referred shall be final and binding upon both parties until the completion of the works, and shall forthwith be given effect to by the Contractor who shall proceed with the works with due diligence, whether he requires arbitration as hereinafter provided or not. If the Commissioner has given written notice of the decision to the Contractor and no Claim to arbitration has been communicated within a period of 90 days from receipt of such notice the said decision shall remain final and binding upon the Contractor.

74. Arbitration and Jurisdiction: (As per Circular No. MGC / F / 8659 dtd. 07.09.2019)

If the Commissioner shall fail to give notice of the decision as aforesaid within a period of 90 days after being requested as aforesaid or if the Contractor is dissatisfied with any such decision, then the Contractor may within 90 days after receiving notice of

such decision or within 90 days after the expiration of the first named period of 90 days (as the case may be) require that the matter or matters in dispute be referred to arbitration as hereinafter provided.

i) In case of a contract where the contract price and/or contract value is less than Rs. 5,00,00,000/- (Rupees Five Crore Only), any dispute arising out of or in connection with this contract, including any question regarding its existence, validity or termination, shall be referred to a mutually agreed arbitral tribunal in accordance with the Arbitration and Conciliation Act, 1996 (amended up to date). The arbitral tribunal shall consist of a sole arbitrator, as mutually agreed upon by parties and the said dispute shall be finally resolved by the said arbitral tribunal. The decision of the arbitral tribunal shall be in writing (with reasons) and which will be final and binding upon the parties hereto and the expenses of the arbitration shall be paid as may be determined by the arbitral tribunal. The seat of the arbitration shall be Mumbai. The venue of arbitration shall be within the limits of Brihan Mumbai. The language of the Arbitration shall be English.

If the parties fail to appoint mutually agreed arbitral tribunal, within the period of 30 days from the date of application seeking arbitration in the dispute, the arbitral tribunal shall be appointed by the recognized arbitral institution i.e. Mumbai Centre for International Arbitration (approved by Government of Maharashtra under G.R. no. ARB/Case no. 1/2017/D-19 dtd. 28.02.2017) as per the Arbitration Rules of the Mumbai Centre for International Arbitration then in force ("MCIA Rules").

ii) In case of a contract where the contract price and/or contract value is Rs. 5,00,00,000/- (Rupees Five Crore Only) or more, any dispute arising out of or in connection with such a contract, including any question regarding its existence, validity or termination, shall be directly referred to and finally resolved by the recognized arbitral institution i.e. Mumbai Centre for International Arbitration (approved by Government of Maharashtra under G.R. no. ARB/Case no. 1/2017/D-19 dtd. 28.02.2017) as per the Arbitration Rules of the Mumbai Centre for International Arbitration then in force ("MCIA Rules"). The arbitral tribunal shall consist of a sole arbitrator. The seat of the arbitration shall be Mumbai. The language of the Arbitration shall be English.

In either case, the law governing this arbitration agreement and the contract shall be Indian Law.

75. Copyright:

The copyright of all drawings and other documents provided by the Contractor under the contract shall remain vested in the Contractor or his sub-contractors as the case may be the employer shall have a license to use such drawings and other documents in connection with the design, construction, operation, maintenance of the works. At any time the Employer shall have further license without additional payment to the Contractor to use any such drawings or documents for the purpose of making any improvement of the works or enlargement or duplication of any part thereof, provided that such improvement, enlargement, or duplication by itself or in conjunction with any other improvements, enlargements or duplications already made in accordance with the further license does not result in the duplication of the whole works.

76. Receipts to be signed in firm's name by any one of the partners: Every receipt for money which may become payable or for any security which may become transferable to the Contractor under these present shall, if signed in the partnership name by any one of the partners, be a good and sufficient discharge to the Commissioner and Municipal Corporation in respect of the money or security purporting to be acknowledged thereby, and in the event of death of any of the partners during the pendency of this contract, it is hereby expressly agreed that every receipt by any one of the surviving partners shall, if so signed as aforesaid, be good and sufficient discharge as aforesaid provided that nothing in this clause contained shall be deemed to prejudice or effect any claim which the Commissioner or the Corporation may hereafter have against the legal representatives of any partners so dying or in respect of any breach of any of the conditions thereof, provided also that nothing in this clause contained shall be deemed prejudicial or affect the respective rights or obligations of the Contractors and of the legal representatives of any deceased Contractors interest.

77. Proprietary data

All documents and other information supplied by the Authority or submitted by an Applicant to the Authority shall remain or become the property of the Authority. Applicants are to treat all information as strictly confidential and shall not use it for any purpose other than for preparation and submission of their Application. The Authority will not return any Application or any information provided along therewith.

78. Correspondence with the Applicant

Save and except as provided in this TENDER, the Authority shall not entertain any correspondence with any Applicant in relation to the acceptance or rejection of any Application.

79. Price Variation Clause

The Contractor shall be reimbursed or shall refund to the Corporation as the case may be the variation in the value of the work carried out from time to time, depending on whether the prices of material and labour as a whole rise or fall, and the method adopted for such computations shall be as given below, it being clearly understood that the contractor shall have no claim for being reimbursed on the ground that the price of a particular material or group of materials have risen beyond the limits of the presumptions made in the following paras, however, no price variations shall be made applicable for contracts up to 12 months:

- A. Controlled materials: Price variations shall be permitted in respect of these materials the price level of which is controlled by the Government or its agency. The rate ruling on the date of submission of the tender shall be considered as the basic price of such material for adjustment. Any variation in this rate shall be considered for reimbursement to the contractor or refund to be claimed from the contractor as the case may be. The contractor shall, for the purpose of adjustment submit in original the relevant documents from the suppliers.
- B. Labour and other materials: For the purpose of this contract and for allowing reimbursement or refund on account of variation of prices of (i) labour, and (ii) materials other than materials mentioned in A above, computation will be based on the formula enunciated below which is based on the presumptions that:

- i. The general price level of labour, rises or falls in proportion to the rise or fall of consumer price index number 9 (general) for working class in Mumbai.
- ii. The general price level of materials rises or falls in proportion to rise or fall of whole-sale price index as published by 'Economic Adviser to Govt. of India'.
- iii. And that the component of labour is to the extent of 30 percent of 88 percent and the component of materials is to the extent of 70 percent of 88 percent of the value of the work carried out. The remaining 12 percent being the presumptive profit of the contractor.

a. Formula for Labour component:

$$VL = \frac{(0.88 R) \times 30}{100} \times \frac{(I - IO)}{IO}$$

b. Formula for Material component:

$$VM = \frac{(0.88 R \times 70 - C)}{100} \times \frac{(W - WO)}{WO}$$

Where -

VL= Amount of price variation to be reimbursed or claimed as refund on account of general rise or fall of index referred to above.

I = Consumer Price Index number of working class for Mumbai declared by the Commissioner of Labour and Director of Employment, Mumbai) applicable to the period under reference (base year ending 2004-05 as 100 i.e. new series of indices).

IO = Consumer price index number for working class for Mumbai (declared by the Commissioner of labour and Director of Employment, Mumbai) prevailing, on the day of 28 days prior to the date of submission of the tender.

VM = The amount of price variation to be reimbursed or claimed as refund on account of general rise or fall of wholesale price index for period under reference.

W = Average wholesale price index as published by Economic Adviser to Govt. of India applicable to the period under reference.

WO = Wholesale price index as stated above prevailing on the day of 28 days prior to the date of submission of the tender.

R = Total value of the work done during the period under reference as recorded in the Measurement Book excluding water charges and sewerage charges but including cost of excess in respect of item upto 50 percent

C = Total value of Controlled materials used for the works as recorded in Measurement Book and paid for at original basic rate plus the value of materials used.

- iv. The quantity of the Controlled material adopted in working out the value of 'C' shall be inclusive of permitted wastages as / if mentioned in specifications.
- v. The basic rate for the supply of controlled material shall be inclusive of all the components of cost of materials excluding transport charges incurred for bringing the material from place of delivery to the site.

Computations based on the above formula will be made for the period of each bill separately and reimbursement will be made to (when the result is plus) and refund will claim from (when the result is minus) the contractor's next bill. The above formulae will be replaced by the formulae in Annexure-I as and when mentioned in special conditions of contract.

The operative period of the contract for application of price variation shall mean the period commencing from the date of commencement of work mentioned in the work order and ending on the date when time allowed for the work order and ending on the date when time allowed for the work specified in the contract for work expires, taking into consideration, the extension of time, if any, for completion of the work granted by Engineer under the relevant clause of the conditions of contract in cases other than those where such extension is necessitated on account of default of the contractor.

The decision of the Engineer as regards the operative period of the contract shall be final and binding on the contractors.

- vi. Where there is no supply of controlled items to contractor the component 'C' shall be taken as zero.

C. Adjustment after completion: If the Contractor fails to complete the works within the time for completion adjustment of prices thereafter until the date of completion of the works shall be made using either the indices or prices relating to the prescribed

time for completion, or the current indices or prices whichever is more favourable to the employer, provided that if an extension of time is granted, the above provision shall apply only to adjustments made after the expiry of such extension of time.

- D. Price variation will be calculated similarly and separately for extra items and / or excess quantities and provisional sums calculated under Sub Clause 10 (b)A i)&(ii) and Sub Clause 10 (b) B(ii) based on the above formula/formulae in Annexure-I as and when mentioned in Special conditions of contract; IO and WO being the indices applicable to the date on which the rates under Sub Clause 10 (a)A (i)&(ii) and Sub Clause 10(a) B(iii) are fixed. No price variation shall be admissible for FAIR items created during execution.

80. Maximum Price Variation shall be as follows:

Time Period of Project	Maximum limit of Price Variation
Up to 12 months	No variation allowed
Above 12 months to 24 months	5%
Above 24 months	10%

Note:

1. The extension in time period for the projects originally estimated including monsoon results in change of price variation slabs as mentioned above i.e. from first slab to second slab or from second slab to third slab, then the maximum limit of original slab will prevail.
2. Operative period shall mean original or extended time period of contract.

For example:

Extension of Time period	Maximum Price Variation
If original period of 11 months including monsoon extends to 16. The operative period will be 11+5months.	No variation allowed
If original period of 11 months excluding monsoon extends to 16. The operative period will be 11+5months.	Maximum 5% variation allowed

Price Variation during Extended Period of Contract:

i. Extension Due To Modification & Extension for delay due to BMC:

The price variation for the period of extension granted shall be limited to the amount payable as per the Indices. In case the indices increase or decreases, above/below the indices applicable, to the last month of the original or extended period vide clause 8 (l) (a) (i) and (ii) of standard GCC

ii. Extension Of Time for Delay Due To Contractor:

a. The price variation for the period of extension granted shall be limited to the amount payable as per the Indices in case the indices increase, above the indices applicable, to the last month of the original completion period or the extended period vide above clause 8(l)(a)(i) and (ii) of standard GCC.

b. The price variation shall be limited to the amount payable as per the indices, in case the indices decrease or fall below the indices applicable, to the last month of original / extended period of completion period vide above clause 8(l)(b) of standard GCC, then lower indices shall be adopted.

iii. Extension of Time for Delay due to reasons not attributable to BMC and Contractor (Reference Cl.8(d) of Standard GCC):

The price variation for the period of extension granted shall be limited to the amount payable as per the Indices in case the indices increase or decreases, above/below the indices applicable, to the last month of the original period.

81. Payment:

Interim Payment:

i. Interim bills shall be submitted by the Contractor from time to time (but at an interval of not less than one month) for the works executed. The Engineer shall arrange to have the bills verified by taking or causing to be taken, where necessary, the requisite measurement of work.

ii. Payment on account for amount admissible shall be made on the Engineer certifying the sum to which the Contractor is considered entitled by way of interim payment for all the work executed, after deducting there from the amount already paid, the

security deposit / retention money and such other amounts as may be deductible or recoverable in terms of the contract.

- iii. On request, the contractor will be paid up to 75 percent of the value of the work carried out as an adhoc payment in the first week of next month after deducting there from recoveries on account of advances, interest, retention money, income tax etc. The balance payment due will be paid thereafter.
- iv. No interim payment will be admitted until such time the Contractor have fully complied with the requirement of the Condition no.8 (g) and 8 (h) concerning submission and approval of Network Schedule for the works, as detailed in Condition 8 (h). A fixed sum shall be held in abeyance at the time of next interim payment for non-attainment of each milestone in the network and shall be released only on attainment of the said milestone.
- v. An interim certificate given relating to work done or material delivered may be modified or corrected by a subsequent interim certificate or by the final certificate. No certificate of the Engineer supporting an interim payment shall of itself be conclusive evidence that any work or materials to which it relates is / are in accordance with the contract.

82. Banning/De-Registration of Agencies of Construction works in BMC The regulations regarding Demotion / Suspension Banning for specific period or permanently / De-Registration shall be governed as per the respective condition in Contractor Registration Rules of BMC.

83. JOINT VENTURE (Not Applicable)

In case if Joint Venture is allowed for the Project, the guidelines for JV as follows shall be incorporated in the Tender Document:

- a. Joint Venture should be allowed only when the number of identifiable different works is more than one and/or the estimated cost of tender is more than Rs.100 Crores. JV shall also be allowed for complex technical work below Rs.100 Crores with the approval of concerned AMC
- b. Separate identity/name shall be given to the Joint Venture firm.

- c. Number of members in a JV firm shall not be more than three in normal circumstances, if the work involves only one discipline (say Civil or Electrical). If number of members in JV is required to be more than three, then approval of concerned AMC needs to be sought.
- d. A member of JV firm shall not be permitted to participate either in individual capacity or as a member of another JV firm in the same tender.
- e. The tender form shall be purchased and submitted in the 'name of the JV firm or any constituent member of the JV.
- f. Normally EMD shall be submitted only in the name of the JV and not in the name of constituent member. However, EMD in the name of lead partner can be accepted subject to submission of specific request letter from lead partner stating the reasons for not submitting the EMD in the name of JV and giving written confirmation from the JV partners to the effect that the EMD submitted by the lead partner may be deemed as EMD submitted by JV firm.
- g. One of the members of the JV firm shall be the lead member of the JV firm who shall have a majority (at least 51%) share of interest in the JV firm. The other members shall have a share of not less than 20% each in case of JV firms with up to three members and not less than 10% each in case of JV firms with more than three members. In case of JV firm with foreign member(s), the lead member has to be an Indian firm with a minimum share of 51%.
- h. A copy of Letter of Intent or Memorandum of Understanding (MoU) executed by the JV members shall be submitted by the JV firm along with the tender. The complete details of the members of the JV firm, their share and responsibility in the JV firm etc. particularly with reference to financial technical and other obligation shall be furnished in the agreement.
- i. Once the tender is submitted, the agreement shall not be modified/altered/terminated during the validity of the tender. In case the tenderer fails to observe/comply with this stipulation, the full Earnest Money Deposit (EMD) shall be forfeited. In case of successful tenderer, the validity of this agreement shall be extended till the currency of the contract expires.

- j. Approval for change of constitution of JV firm shall be at the sole discretion of the BMC. The constitution of the JV firm shall not be allowed to be modified after submission of the tender bid by the JV firm except when modification becomes inevitable due to succession laws etc. and in any case the minimum eligibility criteria should not get vitiated. In any case the Lead Member should continue to be the Lead Member of the JV firm. Failure to observe this requirement would render the offer invalid.
- k. Similarly, after the contract is awarded, the constitution of JV firm shall not be allowed to be altered during the currency of contract except when modification become inevitable due to succession laws etc. and in any case the minimum eligibility criteria should not get vitiated. Failure to observe this stipulation shall be deemed to be breach of contract with all consequential penal action as per contract condition.
- l. On award of contract to a JV firm, a single Performance Guarantee shall be required to be submitted by the JV firm as per tender conditions. All the Guarantees like Performance Guarantee, Bank Guarantee for Mobilization advance, machinery Advance etc. shall be accepted only in the name of the JV firm and no splitting of guarantees amongst the members of the JV firm shall be permitted.
- m. On issue of LOA, an agreement among the members of the JV firm (to whom the work has been awarded) has to be executed and got registered before the Registrar of the Companies under Companies Act or before the Registrar / Sub-Registrar under the Registration Act, 1908. This agreement shall be submitted by the JV firm to the BMC before signing the contract agreement for the work. (This agreement format should invariably be part of the tender condition). In case the tenderer fails to observe/comply with this stipulation, the full Earnest Money Deposit (EMD) shall be forfeited and other penal actions due shall be taken against partners of the JV and the JV. This joint venture agreement shall have, inter-alia, following clauses: -
 - i. **Joint and several liability** - The members of the JV firm to which the contract is awarded, shall be jointly and severally liable to the Employer (BMC) for execution of the project in accordance with General and Special conditions of the contract. The JV members shall also be liable jointly and severally for the loss, damages caused to

the BMC during the course of execution of the contract or due to no execution of the contract or part thereof.

- ii. **Duration of the Joint Venture Agreement** -It shall be valid during the entire period of the contract including the period of extension if any and the maintenance period after the work is completed.
- iii. **Governing Laws** - The Joint Venture Agreement shall in all respect be governed by and interpreted in accordance with Indian Laws.
- iv. **Authorized Member** -Joint Venture members shall authorize one of the members on behalf of the Joint Venture firm to dealwith the tender, sign the agreement or enter into contract in respect of the said tender, to receive payment, to witness joint measurement of work done, to sign measurement books and similar such action in respect of the said tender/contract. All notices/correspondences with respect to the contract would be sent only to this authorized member of the JV firm.

No member of the Joint Venture firm shall have the right to assign or transfer the interest right or liability in the contract without the written consent of the other members and that of the employer in respect of the said tender/contract.

- n. Documents to be enclosed by the JV firm along with the tender:
 - i. In case one or more of the members of the JV firm is/are partnership firm(s), following documents shall be submitted:
 - a. Notary certified copy of the Partnership Deed,
 - b. Consent of all the partners to enter into the Joint Venture Agreement on a stamp paper of appropriate value (in original).
 - c. Power of Attorney (duly registered as per prevailing law) in favor of one of the partners to sign the MOU and JV Agreement on behalf of the partners and create liability against the firm.
 - ii. In case one or more members is/are Proprietary Firm or HUF, the following documents shall be enclosed:

- a. Affidavit on Stamp Paper of appropriate value declaring that his Concern is a Proprietary Concern and he is sole proprietor of the Concern OR he is in position of "KARTA" of Hindu Undivided Family and he has the authority, power and consent given by other partners to act on behalf of HUF.
- iii. In case one or more members is/are limited companies, the following documents shall be submitted:
 - a. Notary certified copy of resolutions of the Directors of the Company, permitting the company to enter into a JV agreement, authorizing MD or one of the Directors or Managers of the Company to sign MOU, JV Agreement, such other documents required to be signed on behalf of the Company and enter into liability against the company and/or do any other act on behalf of the company. Copy of Memorandum and articles of Association of the Company.
 - b. Power of Attorney (duly registered as per prevailing law) by the Company authorizing the person to do/act mentioned in the para (a) above.
- o. All the members of the JV shall certify that they have not been black listed or debarred by BMC from participation in tenders/contract in the past either in their individual capacity or the JV firm or partnership firm in which they were members / partners.
- p. Credentials & Qualifying criteria: Technical and financial eligibility of the JV firm shall be adjudged based on satisfactory fulfilment of the following criteria:

Technical eligibility criteria: In case of Work involving single discipline, the Lead member of the JV firm shall meet at least 35% requirement of technical capacity as stipulated in tender document. OR

In case of composite works (e.g. works involving more than one distinct component such as Civil Engineering works, M&E works, Electrical works, etc. and in the case of major bridges, substructure and superstructure etc.), at least one member should have satisfactorily completed 35% of the value of any one component of the project work so as to cover all the components of project work or any member having satisfactorily completed 35% of the value of work of each component during last seven financial years.

In such cases, what constitutes a component in a composite work shall be clearly defined as part of the tender condition without any ambiguity.

Financial eligibility criteria: The contractual payments received by the JV firm or the arithmetic sum of contractual payments received by all the members of JV firm in any one of the previous three financial years and shall be at least **100% of the estimated value** of the work as mentioned in the tender.

84. Compensation for delay:

If the Contractor fails to complete the works and clear the site on or before the Contract or extended date(s) / period(s) of completion, he shall, without prejudice to any other right or remedy of Municipal Corporation on account of such breach, pay as agreed compensation, amount calculated as stipulated below (or such smaller amount as may be fixed by the Engineer) on the contract value of the whole work or on the contract value of the time or group of items of work for which separate period of completion are given in the contract and of which completion is delayed for every week that the whole of the work of item or group of items of work concerned remains uncompleted, even though the contract as a whole be completed by the contract or the extended date of completion. For this purpose, the term 'Contract Value' shall be the value of the work at Contract Rates as ordered including the value of all deviations ordered:

- Completion period for projects (originally stipulated or as extended) not exceeding 6 months: **to the extent of maximum 1 percent per week.**
- Completion period for projects (originally stipulated or as extended) exceeding 6 months and not exceeding 2 years: **to the extent of maximum ½ percent per week.**
- Completion period for projects (originally stipulated or as extended) exceeding 2 years: **to the extent of maximum ¼ percent per week.**

When the delay is not a full week or in multiple of a week but involves a fraction of a week the compensation payable for that fraction shall be proportional to the number of days involved.

Provided always that the total amount of compensation for delay to be paid this condition shall not exceed the undernoted percentage of the Contract Value of the item or group of items of work for which a separate period of completion is given.

- i. Completion period (as originally stipulated or as extended) not exceeding 6 months: **10 percent.**
- ii. Completion period (as originally stipulated or as extended) exceeding 6 months and not exceeding 2 years: **7½ percent.**
- iii. Completion period (as originally stipulated or as extended) exceeding 2 years: **5 percent.**

The amount of compensation may be adjusted set off against any sum payable to the contractor under this or any other contract with the Municipal Corporation.

85. Action And Compensation Payable in Case of Bad Work and Not Done as Per Specifications

All works under or in course of execution or executed in pursuance of the contract, shall at all times be open and accessible to the inspection and supervision of the Engineer-in-charge, his authorized subordinates in charge of the work and all the superior officers, officer of the Vigilance Department of the BMC or any organization engaged by the BMC for Quality Assurance and the contractor shall, at all times, during the usual working hours and at all other times at which reasonable notice of the visit of such officers has been given to the contractor, either himself be present to receive orders and instructions or have a responsible agent duly accredited in writing, present for that purpose. Orders given to the Contractor's agent shall be considered to have the same force as if they had been given to the contractor himself.

If it shall appear to the Engineer-in-charge or his authorized subordinates in-charge of the work or to the officer of Vigilance Department, that any work has been executed with unsound, imperfect or unskillful workmanship or with materials of any inferior description, or that any materials or articles provided by him for the execution of the work are unsound or of a quality inferior to that contracted for or otherwise not in accordance with the contract, the contractor shall, on demand in writing which shall be made within twelve months of the completion of the work from the Engineer-in-

Charge specifying the work, materials or articles complained of notwithstanding that the same may have been passed, certified and paid for forthwith rectify, or remove and reconstruct the work so specified in whole or in part, as the case may require or as the case may be, remove the materials or articles so specified and provide other proper and suitable materials or articles at his own charge and cost. In the event of the failing to do so within a period specified by the Engineer-in-Charge in his demand aforesaid, then the contractor shall be liable to pay compensation at the same rate as under clause 8.e. of the general condition of contract in section 9 of tender document (for Compensation for delay) for this default. In such case the Engineer-in-Charge may not accept the item of work at the rates applicable under the contract but may accept such items at reduced rates as the Engineer in charge may consider reasonable during the preparation of on account bills or final bill if the item is so acceptable without detriment to the safety and utility of the item and the structure or he may reject the work outright without any payment and/or get it and other connected and incidental items rectified, or removed and re-executed at the risk and cost of the contractor. Decision of the Engineer-in-Charge to be conveyed in writing in respect of the same will be final and binding on the contractor.

If the penalization amount exceeds maximum limit with respect to Clause 8.e of Standard General Conditions of Contract, then a show cause notice shall necessarily be issued to the contract as to why the contract should not be terminated.

86. Contractors remain liable to pay compensation:

In any case in which any of the powers conferred upon the Engineer In-charge by the **relevant clauses** in documents that form a part of contract as exercised or is exercisable in the event of any future case of default by the Contractor, he is declared liable to pay compensation amounting to the whole of his security deposit. The liability of the Contractor for past and future compensation shall remain unaffected.

In the event of the Executive Engineer taking action against these **relevant clauses**, he may, if he so desires, take possession of all or any tools and plant, materials and stores in or upon the work of site thereof or belonging to the Contractor or procured by him and intended to be used for the execution of the work or any part thereof paying or allowing for the same in account at the contract rates, or in the case of

contract rates not being applicable at current market rates to be certified by the Executive Engineer, may after giving notice in writing to the Contractor or his staff of the work or other authorized agent require him to remove such tools and plants, materials or stores from the premises within a time to be specified in such notice and in the event of the Contractor failing to comply with any such requisition, the Executive Engineer may remove them at the contractors expense or sell them by auction or private sell on account of the Contractor at his risk in all respects and certificate of the Executive Engineer as to the expense of any such removal and the amount of the proceeds an expense of any such sell be final and conclusive against the Contractor.

87. No Claim to Any Payment or Compensation or Alteration in Or Restriction of Work

- a. if at any time after the execution of contract documents, the Engineer shall for any reason whatsoever, desires that the whole or any part of the works specified in the Tender should be suspended for any period or that the whole or part of the work should not be carried out, at all, he shall give to the Contractor a Notice in writing of such desire and upon the receipt of such notice, the Contractor shall forthwith suspend or stop the work wholly or in part as required after having due regard to the appropriate stage at which the work should be stopped or suspended so as not to cause any damage or injury the work already done or endanger the safety thereof, provided that the decision of the Engineer as to the stage at which the work or any part of it could be or could have been safely stopped or suspended shall be final and conclusive against the contractor. The Contractor shall have no claim to any payment or compensation whatsoever by reason of or in pursuance of any notice as aforesaid, on account of any suspension, stoppage or curtailment except to the extent specified hereinafter.
- b. Where the total suspension of Work Order as aforesaid continued for a continuous period exceeding 90 days the contractor shall be at liberty to withdraw from the contractual obligations under the contract so far as it pertains to the unexecuted part of the work by giving 10 days prior notice in writing to the Engineer within 30 days of the expiry of the said period of 90 days, of such intention and requiring the

Engineering to record the final measurement of the work already done and to pay final bill. Upon giving such Notice, the Contractor shall be deemed to have been discharged from his obligations to complete the remaining unexecuted work under his contract. On receipt of such notice the Engineer shall proceed to complete the measurement and make such payment as may be finally due to the contractor within a period of 90 days from the receipt of such Notice in respect of the work already done by the contractor. Such payment shall not in any manner prejudice the right of the contractor to any further compensation under the remaining provisions of this clause.

- c. Where the Engineer required the Contractor to suspend the work for a period in excess of 30 days at any time or 60 days in the aggregate, the Contractor shall be entitled to apply to the Engineer within 30 days of the resumption of the work after such suspension for payment of compensation to the extent of pecuniary loss suffered by him in respect of working machinery remained idle on the site or on the account of his having to pay the salary of wages and labour engaged by him during the said period of suspension provided always that the contractor shall not be entitled to any claim in respect of any such working machinery, salary or wages for the first 30 days whether consecutive or in the aggregate or such suspension or in respect of any such suspension whatsoever occasioned by unsatisfactory work or any other default on his part, the decision of the Engineer in this regard shall be final and conclusive against the contractor.

88. Contractor to supply plant, ladder, scaffolding, etc. and is liable for damages arising from non-provision of lights, fencing, etc.

The Contractor shall supply at his own cost all material, plant, tools, appliances, implements, ladders, cordage, tackle scaffolding and temporary works requisite or proper for the proper execution of the work, whether, in the original altered or substituted form and whether included in the specification of other documents forming part of the contract or referred to in these conditions or not and which may be necessary for the purpose of satisfying or complying with the requirements of the Engineer as to any matter as to which under these conditions is entitled to be

satisfied, or which is entitled to require together with the carriage therefore to and from the work.

The Contractor shall also supply without charge, the requisite number of person with the means and materials necessary for the purpose of setting out works and counting, weighing and assisting in the measurements of examination at any time and from time to time of the work or materials, failing which the same may be provided by the Engineer In-charge at the expense of the contractor and the expenses may be deducted from any money due to the contractor under the contract or from his security deposit or the proceeds of sale thereof, or offers sufficient portion thereof.

The contractor shall provide all necessary fencing and lights required to protect the public from accident and shall also be bound to bear the expenses of defense of every suit, action or other legal proceedings, that may be brought by any person for injury sustained owing to neglect of the above precautions and to pay any damages and cost which may be awarded in any such suit action or proceedings to any such person or which may with the consent of the contractor be paid for compromising any claim by any such person.

89. Prevention of Fire:

The contractor shall not set fire to any standing jungle, trees, brushwood or grass without a written permit from the Engineer In-charge. When such permit is given, and also in all cases when destroying cut or dug up trees brushwood, grass, etc., by fire, the contractor shall take necessary measure to prevent such fire spreading to or otherwise damaging surrounding property. The Contractor shall make his own arrangements for drinking water for the labour employed by him.

- 90.** Compensation for all damages done intentionally or unintentionally by contractor's labour whether in or beyond the limits of BMC property including any damage caused by spreading the fire shall be estimated by the Engineer In-charge or such other officer as he may appoint and the estimate of the Engineer in-charge to the decision of the Dy. Chief Engineer on appeal shall be final and the contractor shall be bound to pay the amount of the assessed compensation on demand failing which the same will be recovered from the Contractor as damages or deducted by the

Engineer In-charge from any sums that may be due or become due from BMC to contractor under this Contract or otherwise. Contractor shall bear the expenses of defending any action or other legal proceedings that may be brought to prevent the spread of fire and he shall pay any damages and costs that may be awarded by the Court in consequence.

91. In the case of Tender by partners, any change in the constitution of the firm shall be forthwith, notified by the contractor through the Engineer In-charge for his information.

92. Action where no specifications:

In the case of any class of work for which there is no such specifications, such works shall be carried out in accordance with the specifications and in the event of there being no such specifications, then in such case, the work shall be carried out in all respects in accordance with all instructions and requirements of the Engineer In-charge.

93. Safety and medical help:

- i. The Contractor shall be responsible for and shall pay the expenses of providing medical help to any workmen who may suffer a bodily injury as a result of an accident. If such expenses are incurred by BMC, the same shall be recoverable from the contractor forthwith and be included without prejudice to any other remedy of BMC from any amount due or that may become due to the Contractor.
- ii. The contractor shall provide necessary personal safety equipment and first-aid box for the use of persons employed on the site and shall maintain the same in condition suitable for immediate use at any time.
- iii. The workers shall be required to use the safety equipments so provided by the contractor and the contractor shall take adequate steps to ensure the proper use of equipments by those concerned.
- iv. When the work is carried on in proximity to any place where there is risk or drawing all necessary equipments shall be provided and kept ready for use and all necessary steps shall be taken for the prompt rescue of any person in danger.

94. No compensation shall be allowed for any delay caused in the starting of the work on account of acquisition of land or in the case of clearance of works, on account of ant delay in according to sanction of estimates.

95. Anti-malaria and other health measures:

Anti-Malaria and other health measures shall be taken as directed by the Executive Health Officer of BMC. Contractor shall see that mosquito genic

conditions are created so as to keep vector population to minimum level. Contractor shall carry out anti-malaria measures in the area as per the guidelines issued by the Executive Health Officer of BMC from time to time.

In case of default, in carrying out prescribed anti-malaria measures resulting in increase in malaria incidence, contractor shall be liable to pay BMC on anti- malaria measures to control the situation in addition to fine.

SECTION 10

SPECIAL CONDITIONS

OF CONTRACT

SPECIAL CONDITIONS OF CONTRACTS

1. The sewer lines under the scope of work are of non-man entry sizes and heavily silted to the extent of 40 to 60% and as such the quantum of silt to be removed is considerable. The sewer lines are located in densely populated area.
2. Use of power bucketing or other means shall not be allowed for de-silting of the sewer lines.
3. Since the work is to be completed in time bound manner, the contract period of 06 months (excluding monsoon) starting from issue date of P.O., unless otherwise stated, is including Mobilization Period of 15 days. The contractor shall mobilize the resources and complete preparatory works within the period of 15 days.
4. Considering urgency of the work and looking at the quantum of silt to be removed, the successful bidder shall utilize all the state of art modern technology machinery such as Vehicle Mounted High-Capacity Suction cum Jetting Machine/High-Capacity Super Sucker Machine with dump tank having capacities not limited to the following:
 - Vacuum pump – Min. 6000 CuM /Hr FAD, 80% max. vacuum
 - High pressure jetting pump – Min. 260 LPM capacity, 140 Bar pressure
 - Underground suction attachment of Robotic system (ATEX Zone 2 compliant) along with tracking arrangement, suitable attachments and arrangements like dozer and drilling, CCTV, etc. for barrel cleaning suitable for sewer sizes in the scope of work. The bidder shall produce documentary evidence regarding ownership or lease possession agreement with the owner of above-mentioned robotic system in packet 'A' and 'B'.
5. The bidder shall produce documentary evidence regarding ownership of 02 nos. of Vehicle Mounted High-Capacity Suction cum Jetting Machine/High-Capacity Super Sucker Machine with dump tank of above-mentioned capacities or more in packet 'A' and 'B'. Also, the bidder shall demonstrate the machines along with robotic suction attachment as mentioned above to be utilized for this work before opening of price Packet 'C.'
6. The contractor shall have sufficient standby dump tank vehicle facility for efficient transportation of removed silt to the dumping site. Also, if necessary, the contractor

shall deploy additional machinery, allied equipments and man power so as to complete the work in stipulated time period.

7. By experience, it is observed that there could be variations in the length of the sewer stretch and / or the size of the sewer line. The exact lengths and size under the scope of the work shall be ascertained by the Contractor after the de-silting and CCTV inspection / physical measurement of the sewer lines under the scope of the work. Variation in BOQ size to the limit of $\pm 15\%$ shall be considered acceptable and shall be carried out at the same rate of respective BOQ size.
8. Some of the manholes on the proposed sewer lines are of rectangular vertical type having size approximately 350 x 700 mm and conical type having opening of 590 mm dia. It is presumed that contractor's machinery is compatible for de-silting of sewer lines through such manholes.
9. It is up to the Contractor to fully explore the site conditions to get acquainted with the site conditions and nature of the work before submitting the bid documents. Ignorance of any nature and claims arising out of it will not be entertained at any cost.
10. In case of savings in the scope of work, alternate stretches of sewer lines shall be provided to the contractor anywhere in BMC region within the contract cost with the sanction of Engineer of the Contract. The decision regarding same will be taken by the Engineer of the Contract and it will be binding on the contractor.
11. In case of ongoing works to be considered, the bidder must have received payment bills of 80% of the contract sum for the work / works executed last day of month previous to the one in which bids are invited.
12. In case of noncompliance of any of the technical requirements, the bid shall be liable to be rejected and Price Packet 'C' of the bidder shall not be opened.
13. In case of any doubt or dispute the guidelines mentioned in Standard Bid Document (SBD) and / or the decision of Competent Authority of BMC will be final.

SECTION 11

SPECIFICATIONS

SPECIFICATIONS

Subject : Systematic Cleaning of Sewers of sizes 600mm and below in Eastern Suburb Area.

1. Part 1 - General Requirement

1.1. Specification

These specifications are intended for general description of site conditions, scope of work and requirements, products, execution, quality of workmanship and finished work. They are not intended to cover minute details. The work shall be executed in accordance with best modern practices and using special techniques.

The Contractor shall read this Technical Specification in conjunction with the standard specification of the Municipal Corporation of Greater Mumbai for Sewerage Works and other documents and technical manual, papers, guidelines, standards and specification etc. referred to in the specification. For Civil, Mechanical & Electrical works, BMC's respective standard specifications shall be applicable during execution of the project. Bidders are requested to get acquainted with the same before bidding.

1.2. Contractor's Obligation

The clauses in this section are meant to provide general guidelines and compliance requirements to the Contractor. It does not however relieve the Contractor from (a) taking all precautions as deemed necessary to complete the work successfully within the specified contract period and bided amount and (b) his prima facie obligation and responsibility under the contract to successfully execute the work without causing interruptions to road and pedestrian traffic.

It is deemed that the Contractor's rates in the Bill of Quantities are for successfully execution of work activities included in the scope of works within the specified contract period regardless of the method considered as suitable in this specification.

1.3. Background Information Project

1.3.1. Tidal Data

Sea water levels are recorded in the Automatic Gauge Recorder at Apollo Bunder. The tidal cycle is twice daily, but because of an appreciable diurnal element, unequal tides are produced on most days causing wide variation in extreme levels. This variation is

sufficient to cause to lowest high water to be lower than the highest low water level.

Statistical studies indicate that:

- a. All high tides exceed +2.70 m.
- b. About 5% of all high tides would be less than +3.20 m.

There is a considerable impact of the tidal effects to the sewage conveyance system. Since there are believed to be a number of interconnections between sewage conveyance system and storm water drains, sea water finds its way to sewers under high tide conditions.

1.3.2.Flooding Spots

Flooding can occur in the city area as a result of a number of factors including rainfall, rainfall in conjunction with high tides and Storm Drain blockages or collapses. There appears to be little reported evidence for sewage flooding as a direct result of inadequate sewer hydraulic capacity, though part of the sewage may be flowing in the storm water drainage system. No work on sewers shall be permitted during monsoon season. Similarly, no excavation shall be permitted during notified period. The intrusion of the storm water flow in the sewage system is to increase the hydraulic load on both the conveyance and pumping systems and due to its effect on the sewer infiltration / leakages, may result in possible disturbance of the ground in areas with fine granular or poor soil conditions.

1.3.3.Ground Water

A systematic hydro-geological survey of Greater Mumbai areas was carried out by Central Ground Water Board (CGWB) in 1989-90, based on the measurement of the water levels in open wells in Greater Mumbai and the adjacent hinterland areas. During both pre and post monsoon periods it was observed that the water levels were between 0 and 2m depth in coastal areas (low lying tracts) 2 and 4 m or more in the central elevated part of Salsette, Trombay and Southern tip of Bombay Island. In most of Greater Mumbai, the seasonal fluctuation was less than 2 m and 1989 it worked out to only 0.76 m. Seasonal fluctuation of ground water table in the central elevated part varied between 0 to 6.59 m. The data pertaining to the groundwater table confirms

that the majority of the sewer lines and almost all the normally deep sewers remain below the groundwater table throughout the year.

The ground water during monsoon period is expected to be high and some time it is up to the ground level. For the purpose of designing liners, the Contractor shall consider that the ground water level is up to the ground level.

1.3.4. Manholes

The manholes constructed on the sewerage system in Mumbai are usually conical tapering manholes and trapezoidal and square scraper manholes. The conical manhole is provided with the clear opening of 560 mm at the top while the opening for trapezoidal manholes is 0.6 m x 0.9 m and that for scraper type is 1.2 m x 0.9 m. The bottoms of the conical manholes are 1.2, 1.5 m, 1.8 m. diameter. The bottoms of the scraper manholes on sewers under reference are 1.5m or 1.8m square. Some of the manholes are rectangular vertical type having size approximately 350 x 700 mm. For easy access to the sewer body, the manholes are generally provided at a distance of 30m.

1.4. Contractor's responsibility of ascertaining extent of work

The Contractor is deemed to have visited the sites and familiarised himself of the conditions, restrictions and constraints as well as any differences from drawing etc. under which the work will be executed. The omission of any details shall not relieve the Contractor of his prima facie obligation and responsibility under the Contract to carry out and successfully complete the works. No monetary or other claims, made by the Contractor on the grounds of want of knowledge will be entertained by the Employer. The Contractor is advised that it is his sole responsibility to ascertain for himself the extent of work that is required to be done in site and to generally obtain his own information on all matters affecting directly or indirectly the execution of the whole works involved in the contract to the complete satisfaction of the Engineer. No claim of extras in consequence of any alleged ignorance in any aspect will be entertained by the Engineer. It must be clearly and definitely understood that the contractor shall be held solely responsible for making all necessary arrangement and coordination with relevant authorities, competent agencies and specialist contractor's

principals and technology providers, etc., and obtaining necessary permissions in time by paying all the applicable, to ensure satisfactory completion of the Contract.

1.5. Performance Requirements

The performance requirements are spelt out in various parts of the contract specification and the Contractor shall ensure that he fully understands and complies with all the requirements specified in the contract. However, in the event of any conflicting performance requirements in the documents, the Contractor shall promptly bring such matters in writing to the attention of the Engineer for a clarification and/or decision. The Engineer's decision will be conveyed to the Contractor in writing and his decision shall be final. The Contractor shall fully comply with Engineer's decision on the matter.

The Contractor is deemed to have studied site conditions, adequacy / suitability of the methodology to be proposed, read and understood all the performance requirements before pricing the Contract and he shall have no claim whatsoever with respect to the Engineer's final decision on the matter.

1.6. Confined Space Safety Procedure for Working in Live Sewers / Manholes

The Contractor shall ensure that all the necessary safety requirements for persons working in sewers, manholes, chambers, and all other sewerage installations are fully complied with all statutory safety requirements and provisions in the BMC's general safety precautions, NHRC guidelines, Competent Courts, OSHA regulations and any other applicable rules, guidelines, amendments in this regard and the clauses in the specification. The requirements and precautions to be taken when working in confined space and in live sewers are specified in the specification Part 5- Guidelines for Safe Entry and Working inside Sewers.

1.7. Electrical Power, Water Supply

The Contractor shall at his own cost, arrange for electrical power and water required for the execution and completion of the Work.

1.8. Rates to include all method related costs

The bidder is required to quote his rate for the methodology proposed by him and approved by the Engineer.

It is deemed that the rates offered by the Contractor are inclusive of everything required to comply with all the required provisions as above and any additional requirements including sewer isolation, plugging, flow diversion, traffic management, etc. as necessary to carry out the work safely and successfully. The Contractor is also deemed to have considered for any method related contingencies in his rates. Innovation in relation to the best specified methodology and the best practice is encouraged and the Employer will consider all the options to get the best methodology at competitive price. Hence, sufficient documentation must be submitted with the Technical Schedules of the bid to enable the Employer to carry out an initial investigation and appraisal of the product and the method offered and to ascertain the benefit and the advantage of the methodology to the Employer.

1.9. Co-operation with other Contractors and operational facility

The Contractor is advised that there may be other Contractors (i.e. from PWD, MMRDA, other department of BMC or other authorities like Metro, MGL, Private Utility Providers, etc.) working within the site area. The Contractor may therefore be given joint possession, in some sections of the sites, with the other Contractors for the purpose of carrying out his contractual obligation and he shall in no way interfere with, impede or otherwise prevent these other Contractors, from carrying out their contractual obligations. The contractor shall coordinate with all such contractors / agencies and plan / liaison his activities for successful and timely completion of his contract. The Contractor shall allow in his prices, when bidding, for affording reasonable facilities to the other Contractors and for any interference with his work from these other contract operations.

No claim on account of this clause will be entertained by the BMC and his prices are to include for such contingency.

The contractor shall note that it is the responsibility of the contractor to co-ordinate and arrange meetings with Utility Companies or the Government or Municipal departments. The Corporation would arrange to give authority letters to the contractor for arranging such meetings. The Engineer's representative shall be present in such meetings. The Corporation is not contractually bound to accept what

transpired in any meetings or discussions in which the Engineer or the Corporation was not represented.

1.10. Transport of Materials

It shall be noted by the Contractor that the transport of the equipments and materials and movement of vehicles overland will be subject to regulation of transport by various statutory authorities. The same will be applicable for materials and equipments required to be imported for the contract. The Contractor's rates/prices shall include for all costs arising from the imposition of traffic hours restriction by the Traffic Police, import export duties and other shipping charges as applicable. The Bidder is advised to obtain accurate information from the concerned authorities before bidding for the work.

1.11. Assistance for the Engineer's Staff

The Contractor shall provide all necessary assistance to the BMC/Engineer's Representative and his staff in carrying out their duties of checking the setting-out, inspecting and measuring the works. The Contractor shall provide chainmen, staffmen, office attendants and labourers as may be needed from time to time by the Engineer's Representative. One labourer shall be deployed at all times at the Engineer's site office to assist the Engineer.

The Contractor shall provide for the Engineer's Representative and his staff such protective clothing, safety helmets and rubber boots of suitable sizes, hand lamps and the like as may be reasonably required by them. These articles shall remain the property of the Contractor.

1.12. Access and Site Roads

The contractor shall construct, maintain and afterwards remove and reinstate site roads and accesses required for the execution of the works. The reinstatement of the roads shall be as per the latest norms and guidelines / circular of BMC. Unless the Contract otherwise provides, the cost of such works shall be borne by the Contractor.

1.13. Use of I.S. Specifications

In case no particular specification is given for any work to be done under the contract, the relevant specifications, where exists, of the Indian Standard Institutions shall apply.

1.14. Claims for Damage to Persons or Property

Any claim received by the Employer in respect of matters in which the Contractor is required under the Contract to indemnify the Employer will be passed to the Contractor who shall likewise inform the Employer of any such claim which is submitted directly to him by a claimant.

The Contractor shall do everything necessary, including notifying the insurers of claims received, to ensure that all claims are settled properly and expeditiously and shall keep the Employer informed as to the progress made towards settlement, failing which the Employer shall be entitled to make direct payment to claimants of all outstanding amounts due to them in the Employer's opinion and without prejudice to any other method of recovery to deduct by way of set-off the amounts so paid from sums due or which become due from the Employer to the Contractor.

If the Contractor receives a claim which he considers to be in respect of matters for which he is to be indemnified by the Employer under the Contract he shall immediately pass such claim to the Employer. All information as aforesaid shall be given in writing and shall be copied to the Engineer's Representative.

1.15. Existing Services

The Contractor shall take all due care and necessary precautionary measures to ensure that no damage occurs to any existing sewer, water or gas mains, electricity or telephone cables culverts and any other existing services. Any damage arising out of the Contractor's work in such respect will be met with entirely by the Contractor and no claim to the contrary will be entertained by the Corporation.

1.16. Working Space

The Contractor shall note that within probable sewer projected area on surface or immediately adjoining the outside of the sewer reserves, other services may have already been laid and his attention is particularly drawn to his responsibility for the maintenance of other services. The Contractor will be allowed working space outside

reserves, where approval for its use is obtainable by him from the owners/authorities, but the Contractor will be required to limit his working space where obstruction to traffic is likely or access to adjoining sites or services is affected.

Any additional working space required by the Contractor will be entirely the Contractor's responsibility and he will be required to obtain all necessary consents, pay all the costs arising out of compensation, etc. and reinstate the land affected to the satisfaction of the owner and the Engineer.

1.17. Bench Mark

The Contractor shall establish substantial bench marks and fixed points on the site to the Engineer's direction and shall ensure that these are not damaged or disturbed. All such bench marks and fixed points must be referred to a Master Bench Mark and follow Town Hall Datum (THD) as maintained by the BMC. All survey works shall be compatible to upload the information into the GIS system maintained by BMC after the approval of the Engineer.

1.18. Contractor's Plant/Equipment

All mechanical plants/Equipments used by the Contractor in the execution of the Works must be of such type, size and of such method of working as the Engineer shall approve. The Engineer's approval to the use of mechanical plants/Equipments will not be unreasonably withheld, but if in the Engineer's opinion, circumstances arise which make it desirable that the use of plants should be suspended either temporarily or permanently, the Contractor shall change the method of performing the work affected at his own cost and he will be deemed to have no cause for claim against the Corporation on account of having to carry on the work by another method nor will he be deemed to have cause for claim if any order issued by the Engineer results in the mechanical plant/Equipment having either to stand idle for a period of any duration whatsoever or to be removed.

This clause shall apply also to plants which, in the opinion of the Engineer, are not as quiet in operation as the circumstances seem to the Engineer to warrant.

The Contractor shall use every possible means to prevent noise and annoyance to the residents of the neighbourhood in which the works and the Contractor's depots are

situated and all machinery must be of such design and so arranged to be reasonably free of noise in working.

In the event of air compressors or pneumatic tools being used on the Works, the Contractor shall, if and when required by the Engineer, arrange for such compressors or tools to be fitted with silencers of approved design or adopt other means approved by the Engineer for the purpose of reducing noise as far as possible to the desired decibel limits.

The Contractor will not be allowed to make any extra charge for work or expense incurred in complying with the requirements of this clause.

1.19. Anti-pollution and Mosquito Control

The site and working areas shall be maintained at the Contractor's expense in accordance with current existing regulations governing anti-pollution and mosquito control and other civic statutory requirements of maintaining healthy site conditions all the time.

1.20. Safeguarding Properties Adjacent to Site

Where work is undertaken near or adjacent to buildings and in the opinion of the Engineer, the stability of such buildings is liable to be affected as a result of the work, he shall arrange to have such buildings inspected and to have record any cracks or any other defects which may be affected by the work. Every precaution should be taken by the Contractor to safeguard such building or structure and they should be to the complete satisfaction of the Engineer. The Contractor may be directed by the Engineer to excavate in such lengths of excavation as will permit the least amount to be opened at one time in order to minimize to danger of such open excavation affecting the stability of buildings or their supports.

The Contractor will be held responsible for damage to public, private or other buildings and properties adjacent to the site of the works which is caused as a direct or indirect result of the Contractor's work. Should the Contractor fail to take the necessary precautions the Engineer may, after giving the Contractor twenty-four (24) hours notice in writing, carry out such work as may be necessary using Corporation labour,

material, plant, implements and transport. The cost of such work will be charged to the Contractor.

The Contractor must take due care to safeguard all existing services, such as water, sewer or gas mains, electricity telephone cables, required to excavate *trial pits in advance of the Works and determine accurately the position of mains, pipes etc. The Contractor shall notify the Engineer of any mains, pipes or conduits met which in trial pits or excavation and shall take steps to support and protect these to the satisfaction of the Engineer. The Contractor will be responsible for any damage done to mains, cables, culverts and other services, inside or outside the excavation as a result of earth movement, faulty timbering, excessive weight of excavated material being deposited too close to open trench, leaving the excavation open for an unduly long period or to any form of settlement following backfilling.

No work done by the Engineer or his workmen nor the fact that the timbering has complied with this Specification or neither requirements of the Engineer nor the approval of proposed or completed timbering etc, by the Engineer shall absolve the Contractor from his responsibilities and he will be required to make good any damage caused as a result of the timbering failing to give proper support to the sides of the excavation.

Furthermore, the Contractor is required to conform to any other safety and fire regulations that may be introduced from time to time.

1.21. Method of Working

The Contractor is required to carry out the Works in the manner detailed herein, shown on the drawings and normally adopted. He is at liberty to supply with his Bid such modification as he proposes for consideration and shall seek approval from the Engineer before he is allowed to apply new or changed methods for execution of the work. Notwithstanding any Specification, approval of decision given by the Engineer as to the carrying out of the Works, the Contractor will be wholly liable for the safety of the works, both temporary and permanent and for the completion of the Contract to the satisfaction of the Engineer.

1.22. Traffic Permissions

As directed by Municipal Commissioner of BMC vide circular no. MGC/A/2035 dated 24.01.2020, the proposed work are to be executed with intimation to the traffic department in advance to facilitate traffic diversion. The contractor shall prepare traffic management plan so that the vehicular & pedestrian traffic is least affected.

It must be clearly and definitely understood that the contractor shall be held solely responsible for making all necessary arrangement and co-coordinating with traffic authorities to facilitate traffic diversion, in time to work in the designated stretches.

It is deemed that the rates offered by the Contractor have included everything required to comply with all the required provisions as above and any additional requirements as necessary to carry out the work under the scope of the contract smoothly.

1.23. Special Traffic Precautions

The Contractor's attention is specially drawn to the requirements by the traffic police and road authorities and Specifications regarding Traffic Control, Access and the Reinstatement of road surfaces etc. It is quite likely that movements of heavy vehicles (trucks/dumpers/tankers etc) may be regulated or prohibited by the authorities during certain period of the day. The Contractor shall plan his activities with due regards to such restrictions/regulations in coordination with traffic authorities.

The Contractor's progress/programme and road opening schedule must be arranged in details for discussion with the Engineer and the Traffic Police. The sewer stretches under the scope must be broken into suitable sections and wherever necessary, special traffic diversions shall be arranged.

Whenever carriage ways are affected, the Contractor must arrange to contain the works within the narrowest possible area. The Contractor shall carry out the work in such a manner as to cause minimum interference with the public use of roads, footpaths and other through fares. All workmen working on roads are required to wear approved retro-reflective vests and other safety measures at all times during execution of work. The Contractor shall, include in his rates for compliance with all the conditions stipulated above.

The work sites must be barricaded in accordance with standard methods as specified in the General Conditions of Contract for construction works of BMC.

It will be entirely responsibility of the contractor to provide and install secure barricades on the work site, wholly at his cost. The specification and drawings of the barricades to be provided are as per Circular u/no. MGC/F/6342 dated 5.5.2018 Annexed.

1.24. Traffic Control

The Contractor will be required to arrange the work sites and order of working in or alongside carriageways to minimize the interference with the free flow of traffic and shall take all measures and precautions required by the Traffic Police, Road Authorities and the Engineer for the safety and convenience of traffic.

The stretches of work sites must be arranged in length to ensure free flow of road traffic in such a manner to be consistent with good progress in execution of work.

The Contractor must provide and maintain at each work site proper and efficient automatic traffic lights operating day and night for the full duration of the Works. The use of stop and go boards will not be accepted as an alternative to traffic lights at the main work sites.

1.25. Road Opening

The works intended under this contract are essentially required to be executed by absolute trenchless technique and any excavation needed by the contractors for the purpose of accessing the sewer line shall be kept as minimum as possible. Excavation needed for the purpose of diversion of flow to the nearest manhole shall also be kept to bare minimum.

In case, if opening of road or excavating upper portion of the manhole is necessary, the Contractor shall submit a detailed road opening schedule to the Engineer for approval. The Contractor shall contain the works within the narrowest possible area when opening the road for access to sewer line.

Traffic flow must be maintained at all times along the roads affected by the work. Sufficient lighting road signs, barricades and traffic diversion signs must be established

along the sites of the works in accordance with the Traffic Police requirements and to the entire satisfaction of the Engineer.

The Contractor shall also comply with the conditions imposed by Traffic Police and Roads Opening Conditions and Requirements stipulated by BMC. Upon completion of the work, the Contractor shall backfill and make good all disturbances to the road, side table, road kerb and drains to the satisfaction of the Road authorities and the Engineer.

The work shall be carried out at night time as far as possible to minimize the disturbance. If required, the Pits/trenches shall be covered with decking plates with appropriate support so that all traffic shall be allowed to run over the decking during day time. If directed by the authorities or the Engineer, the Contractor shall construct temporary diversions on the roads at his own cost to allow the traffic to flow through during the construction.

1.26. Road Re-instatement to Road Authority's Requirements

Wherever necessary the Contractor shall carry out the reinstatement of road foundation and road surface in accordance with the specifications and requirements of the Roads authorities. This shall include machine-paving as and when directed by the Engineer. If any authority demands any deposits or charges for reinstatement for road opening permissions, the contractors shall pay the same to such authorities directly. Such amount shall not be reimbursed by the Engineer under any circumstances.

Where road markings are affected, the Contractor shall reinstate it with thermoplastic (instead of paint) to the satisfaction of Roads authorities. The Contractor shall include in his rates for compliance with all the conditions stipulated above.

1.27. Partial Covering up of Road in Busy Areas

Where it is necessary to open the road for access to sewer line, in busy roads, the top of the openings shall be covered by decking, if required by traffic authorities, leaving only the minimum required area open at the top to carry out work within the shaft. Vehicles shall be permitted to travel over such covers provided and hence must be designed and constructed accordingly. The Contractor shall submit to the Engineer,

details of the partial covering. He shall allow for compliance of this requirement in his rates.

1.28. Reinstatement of Surface

The contractor shall be responsible for the reinstatement and maintenance of foundation and surface of roads, kerbs, footways and turfed areas, whether public or private, disturbed or damaged by any activities in connection with the work, and the prices quoted shall include such works.

The contractor shall allow for carrying out this reinstatement work in one or more stages, the maintenance of the reinstatement shall be to the satisfaction of the Engineer. This shall include the provision of temporary surfacing, its maintenance and subsequent breaking out and removal of temporary surfacing required for the reinstatement of final carriageways.

The contractor shall also make provision for any additional width in short lengths or in stages as considered required by the Engineer due to the Contractor's operations or to subsidence or traffic. The contractor shall carry out the reinstatement of road foundation and road surface in accordance with the specifications and requirements of the Roads Authorities.

This shall include machine-paving as and when directed by the Engineer. Where road markings are affected, the contractor shall reinstate it with thermoplastic to the satisfaction of Road Authorities. The contractor shall include in his rates for compliance with all the conditions stipulated above. In the event of the contractor failing to carry out maintenance work, the Engineer may get this work done as set out in the specification through any other contractor, in which case, the cost so incurred shall be borne by the contractor and deducted from money due or to become due to the contractor. The contractor shall also allow for matching paving in all reinstatement of road surfaces. The contractor must follow the safety rules as required. The contractor shall allow for all the above in his rates.

1.29. Permissions from municipal ward offices

The contractor shall be responsible for taking permissions of local municipal ward offices before commencing and carrying out work in their respective territorial

jurisdiction, before setting up temporary office/chowky in the ward jurisdiction and also before taking trenches/pits on the road surface and for the like activities. Necessary letters seeking permissions will be issued by the department. However, obtaining permission by regular follow up with the ward staff shall be contractor's sole responsibility. Obtaining necessary permissions from other departments of M.C.G.M. or any other organisation/authority shall also be contractor's responsibility.

1.30. Restriction on Working Hours

Generally, the Contractor shall be allowed to work only during the night hours in streets where the traffic is heavy. However, the works may be continued during busy hours during the day provided the Engineer shall allow him to authorize such work. Contractor is deemed to have included in his rates the cost of construction of all starting and ending pits required, if any. It must be clearly and definitely understood that the contractor shall be held solely responsible for making all necessary arrangement and co-coordinating with relevant authorities, competent agencies and obtaining their permissions in time to carry out the activities smoothly during the permitted working hours.

1.31. Night – Work

Contractor's attention is drawn to the prevailing situations on the sites which may require all the activities related to de-silting of sewers under the scope of the work to be carried out during the night hours only. All equipment used shall comply with the acceptable noise emission levels. In general it must be ensured that planned work for shift is completed within time and site cleared for allowing traffic or regular activities for every shift of work (night).

It is deemed that the rates offered by the Contractor have included everything required to comply with all the required provisions and any additional requirements as necessary to carry out the sewer de-silting work during night hours.

1.32. Continuous Working

If, in the opinion of the Engineer it is necessary, by reason of the safety of the works, or the restoration of interrupted services or for any other reason whatsoever, the Contractor shall, when so ordered carry out the works or any portion thereof

continuously by day and by night in a safe manner at no additional cost to the BMC. All permissions needed in such cases shall be the Contractor's responsibility.

It shall be clearly and definitely understood by the Contractor that no claims in respect of any of the above shall be allowed in the settlement of the Final Account.

1.33. Effect of Approval and Acceptance of Proposals

Approval or acceptance by the Engineer of any proposal for executing the Works, including drawings, specifications or resources employed under the Contract shall not relieve the Contractor of his responsibility for any errors thereon and shall not be regarded as an assumption of risk or liability by the Corporation. The Contractor shall have no claim whatsoever under the Contract on account of the failure or partial failure or inefficiency of any plan, method of work or equipment approved or accepted by the Engineer. Such approval or acceptance shall be considered to mean only that the Engineer had no objection to these proposals.

Notwithstanding any approval or acceptance by the Engineer, the Contractor shall remain fully responsible for completing the Works correct in every detail.

Schedule of submittals detailing the time when the documents are to be submitted is given below for the reference.

1.34. Reference Documents and Standards

The contractor shall execute the whole and every part of the work in most substantial and workmen like manner, both as regards to materials and otherwise in every respect in strict accordance with BMC specification latest edition, relevant WRC, WIS, ASTM, BIS, ISI, CPHEEO and other relevant specifications etc as may be specifically provided for.

2. Part 2 - Objective & Existing Site Details

2.1. Objective

Brihanmumbai Municipal Corporation has sewer network of about 2052 kms having various sizes of man-entry and non-man entry sewer lines. In the present tender, BMC intends to undertake of systematic de-silting of selected non-man entry sewer lines of circular, located in Eastern Suburb area, with specialised vehicle mounted high-capacity suction cum jetting machine / high capacity super sucker machine with dump tank. The schedule of sewer lines included in the scope of work is as follows:

Sr. No.	Sewer Stretch / Location	Ward	Size & Shape of Sewer (mm)	Tentative Length As per GIS (mtr)	Rehabilitation Status
1.	Ashok Nagar, Marwa Rd., Sakinaka.	L	500/600 (Circular)	306	Not Rehabilitated
2.	RC Marg (From Bharat Petroleum mono station to Micado Bar)	M/W	500 (Circular)	1941	Not Rehabilitated
3.	Periphery Road (From Kena Market Maidan to GMLR Jn.)	M/E	600 (Circular)	768	Not Rehabilitated
4.	V. N. Purav Marg (From Deonar Farm Road Jn. to Anushakti Nagar)	M/E	600 (Circular)	1106	Not Rehabilitated

Total length of sewer lines to be de-silted under this project is **4121 Mtr.**

2.2. Existing Site Details

Most of the aforementioned sewer lines to be de-silted are located in densely populated area and are age old made of concrete or concrete lined bricks. The sewer lines are not rehabilitated. These sewer lines are envisaged to be heavily silted to the extent of 40% to 60% and as a result the connected sewer network remains in surcharge condition giving rise to unhygienic and unhealthy conditions causing inconvenience to the locals.

As such, the subject tender is invited for de-silting of aforementioned sewer lines with specialised vehicle mounted high-capacity suction cum jetting machine with dump tank / High-Capacity Super Sucker Machine with dump tank. In addition to this, it is expected that the successful contract shall undertake local repairs and dimension check of the sewer lines in the scope of work as per the requirement.

Contractors are requested to refer to the Contract Drawings for tentative alignment and start and end points of the aforementioned sewer lines under the scope of work.

By experience it is observed that there could be variations in the length of the sewer stretch and or the size of the sewer line. The exact lengths and size under the scope of the work shall be ascertained by the Contractor after the de-silting and CCTV inspection of the sewer lines under the scope of the work.

In case of savings in the scope of work, alternate stretches of sewer lines shall be provided to the contractor anywhere in BMC region within the contract cost with the sanction of Engineer of the Contract. The decision regarding same will be taken by the Engineer of the Contract and it will be binding on the contractor.

Defects in Sewer Lines -

The commonly found defects in the sewers lines includes -

- Displaced and open joints.
- Structurally deteriorated, broken pipes.
- Longitudinal and circumferential cracks and fractures.
- Hydrogen sulphide related corrosion in sewer which causes the sewer pipe to collapse.
- Debris, Obstructions, roots mass growth and Encrustations.
- Siltation caused by poor gradients (including reverse gradients, elevated sewer sections) & sunken sections of sewer.
- Infiltration through cracks and opened up joints which cause the surrounding soil to erode.

- Connections to storm water drain allowing silt and debris to flow into sewer during rain periods.

It shall not be construed that the above information describes adequately and accurately the actual conditions found in the sewers but provided herein only as a guide to the Contractor. BMC does not assume any responsibility for its accuracy or adequacy and it is up to the Contractor to fully explore the site conditions to get himself acquainted with the site conditions and nature of the work before submitting the bid documents. Ignorance of any nature and claims arising out of it will not be entertained at any cost.

3. Part 3- Execution of Work

The proposed sequence of execution of work is as follows-

- i. Preparatory works including isolation of sewers by Temporary/Permanent plugging.
- ii. Taking trenches for diversion of sewage flow.
- iii. Diversion of Sewage flow by pumping arrangement.
- iv. De-silting and transportation of silt to dumping ground.
- v. After de-silting CCTV survey.
- vi. Local repairs to sewer line.
- vii. Dimension Checking.
- viii. Manhole Repairs.
- ix. Raising / lowering of manholes
- x. Replacement of broken manhole covers
- xi. Construction of manholes, if required.
- xii. Updating data in SUMC section.

The various operations / activities to be performed as per the above sequence are detailed as below.

3.1. Preparatory works

Preparatory works includes making arrangement of necessary safety equipments/ personnel protective gears, tools, tackles, implements, conducting preliminary survey of work site and identifying and locating manholes on the sewer line to be de-silted, making sketches, preparing AutoCAD/ GIS based drawings of sewer line showing thereon manholes, adjacent sewer/storm water network, arrangement of diversion of sewage flow, making locations for taking trenches and pits, etc., and preparation and submission of methodology, sewage flow diversion plans, etc. for approval of the Engineer and obtaining permissions from various authorities like ward offices, traffic police department, etc.

This begins with mobilising necessary safety equipments, personal protective gears, tools, tackles, road signs, traffic diversion equipments, manpower, machinery, etc.

The preliminary survey of work site shall then start. In general, most of the roads have storm water and sewer manholes laid along the lengths. It is therefore necessary to locate at site the exact manholes of sewer lines and storm water drains while starting the work. Hence, prior to actual start of work, it is required to carry out detailed survey of the sewer lines in order to understand how the sewer lines are laid and to know correct locations of the sewer manholes.

After preliminary survey, sketches and AutoCAD / GIS based drawings of the sewer line shall be prepared showing thereon locations of manholes, adjacent sewer/storm water network, arrangement of diversion of sewage flow, proposed locations of trenches and pits, etc.

The contractor shall obtain necessary permissions from various Authorities, Municipal Ward Offices as and when required. M.C.G.M. shall provide necessary help and issue request letters seeking necessary permissions / approvals from various authorities for carrying out the work, however, following up with the various departments and obtaining required permissions / approvals shall be solely the contractor's responsibility.

The contractor shall prepare and make necessary submittals such as methodology, sewage flow diversion plans, traffic management plan, safety management plan, etc. for approval of the Engineer.

All the cost towards preparatory work shall be borne by the contractor.

Safety at work

The Contractor shall ensure that all the necessary safety requirements for persons working in sewers, manholes, chambers, and all other sewerage installations are fully complied with all statutory safety requirements and provisions in the BMC's general safety precautions, NHRC guidelines, Competent Courts, OSHA regulations, "Prohibition of Employment as Manual Scavengers and Their Rehabilitation Rules, 2013 (MS Rules 2013)" and as per the clauses in the specifications. The circulars issued by Governmental organisations and its Undertakings/Commissions/Committees

related to safety and compensation policies of the personnel working in sewer environment from time to time will be applicable in case of any mishap or untoward incident happened during execution of work. The requirements and precautions to be taken when working in confined space and in live sewers are specified in detail in the specification.

3.2. Temporary plugging of sewer line by construction of coffer dam.

This includes temporary plugging of sewer line / laterals by constructing a coffer dam of gunny bags / puddle bags in the manhole with safety precautions and in environment friendly manner.

The coffer dams of gunny bags of approximately 150 nos. shall be constructed on the sewer line / laterals to facilitate construction of permanent brick wall pardi at both upstream and downstream ends on the sewer line to be isolated and for the diversion of flow from laterals.

The Gunny bags shall be securely held in position to prevent sliding downwards in the manhole. The coffer dam shall withstand the hydrostatic back pressure likely to be encountered and thus retain the force of waste water.

After completion of the work, the coffer dam shall be completely removed from the manhole and sewer line. A photographic/ CCTV proof of removal of all obstructions in the line shall be provided to the Engineer.

3.3. Permanent plugging of sewer line by construction of brick wall pardi

This includes permanent plugging of sewer line by constructing brick wall pardi in the sewer line with safety precautions and in environment friendly manner.

Immediately after construction of coffer dam, the Contractor shall construct a permanent brick wall pardi of minimum 1 mtr. width at both ends of the sewer line to isolate it permanently for carrying out further activities of the work under scope. The contractor shall also plug all the intermediate body connections, branch connections, laterals in the manholes and any extraneous connection as necessary using appropriate plugging arrangements like mechanical seals / pneumatic plugs, etc.

The plugs shall be securely held in position to prevent sliding and any consequential mishap/accident. The plugs shall withstand the hydrostatic back pressure likely to be encountered and thus retain the force of waste water. The plugs shall be inflated and deflated within the sewer line itself by suitable controls from the road level.

The Contractor may provide secured plugging arrangement/ stanching in the brick wall pardi for release of excess pressure in regulated manner in case need arises. The safety officer shall check the plugs and stanching for safety every time during execution of work.

The brick wall pardi including stanching arrangements, plugs shall be completely removed after the work is completed. A photographic/ CCTV proof of removal of all obstructions in the line shall be provided to the Engineer.

3.4. Taking trenches for diversion of sewage flow

This includes excavation of required size trenches on road for laying sewage flow by-pass pipes including removing, stacking excavated material at site and transporting excavated material to the designated dumping spots including handling and supporting utilities/ drains/ cables/ water mains, etc, payment of any royalty, tax, etc. to any authority, laying sewage flow by-pass pipes and removing after completion of work flow by-pass pipes and backfilling the trenches including making good of the damaged manholes/ sewer lines/ other utilities wherever necessary and reinstatement of road surface as per guidelines/ standards/ norms of roads department of B.M.C. complete all with safety precautions as per specification and as directed.

If trenches are required to be taken for the purpose of laying pipes for diversion of sewage flow to the nearby drain, the same shall be detailed out in the flow diversion plan submitted for the approval of the Engineer of the contract.

3.5. Diversion of Sewage flow by pumping arrangement

This includes diversion of flows by pumping and/or bypassing to maintain the downstream / upstream sewerage system functioning normal without any surcharge, etc. during the work all with safety precautions and in environment friendly manner.

The contractor shall submit the flow diversion proposal to the Engineer for approval. The proposal shall include details of plugging/ blocking of sewers and diversion arrangement either by pumping of upstream flows or by diverting the flows through nearby sewer / storm water drains.

The Contractor is deemed to have inspected the site and ascertained himself about the availability of such bypassing opportunities in the vicinity of the sewer lines to be rehabilitated before pricing the Contract. He shall include all the expenses for controlling the flow during the work whether the sewer / storm water drains are available or not.

Notwithstanding the possibility of bypassing the sewage flows through the nearby sewer/storm water drains, the Contractor is deemed to have included in his prices for alternative diversions/ bypass pumping, etc in the event such facility is neither available nor practical to use on site. The capacity & quantity requirement of pumps shall be calculated on the basis of flow pattern and flow quantity for each area and the same shall be submitted to the Engineer's approval along with the flow diversion plan.

The Contractor shall ensure that the sewerage system is kept in normal operations by providing bypass arrangements or over pumping arrangements using appropriate equipments, pumps, etc. Care shall be taken to prevent any flooding / ponding due to sewage overflows / pumping. The Contractor shall take all measures necessary to prevent pollution of any water source, land as the entity is solely and wholly responsible for compliance with the requirements under pollution control Act and any other statutory provision.

The bypass pumping/flow diversion arrangement shall be continuously monitored and cleaned or cleared off any obstructions due to the silt. The contractor shall ensure that there is no overflow of sewage.

Approval of the Contractors proposals by the Engineer shall not relieve the Contractor of his responsibility to ensure that sufficient and adequate pumping arrangements are provided at all time and for all flows.

The Contractor shall in addition to all the foregoing requirements of this Clause also allow in his rates for the provision for:

1. Operation and maintenance, including establishment and removal, noise suppression of all over pumping plant
2. Operation and maintenance of all delivery hose installed, including establishment and removal and for the period during which by pass pumping work is required
3. Placing horizontal and/ or ramped metal plating over temporary diversion of the delivery hose either in trench or on the road surface and for routing delivery hoses through other conduits
4. Stanching and plugging lateral connections as well as other relevant requirements of the Engineer.

3.6. De-silting and transportation of silt to dumping ground.

This includes loosening, de-silting and thoroughly cleaning invert-lying debris and remove larger debris and objects such as bricks, etc, bacteriological slimes, roots, soft encrustations, grease, carbonated deposits, etc from the sewer line and manholes of any size, shape and up to any depth using High Capacity Suction cum Jetting Machine / High Capacity Super Sucker Machine with dump tank, as the case may be, sprinkling with approved disinfectant on the stacked silt to avoid nuisance of pests and bad odour and transporting the de-silted material to the identified dumping site including, loading, unloading, etc. complete all with safety precautions and in environment friendly manner as per specifications and as directed.

1. De-silting

The de-silting shall be carried out using vehicle mounted high-capacity suction cum jetting machine / high-capacity super sucker machine with dump tank facility.

Each high-capacity suction cum jetting machine / high-capacity super sucker machine shall be equipped with minimum 02 nos. of dump tank of capacity not less than 10 m³ during execution of the subject work.

The Contractor is required to provide said equipment of the appropriate caliber in sufficient quantity to deal with the demanding service conditions, including heavy grease, deposits of silt, cement grout, other debris and high levels of infiltration that the

contractor can expect to encounter in the sewerage network without causing any structural disturbance to the body of the sewer so as to complete the work within stipulated time period.

The Engineer, if not satisfied with the level of cleaning of sewer line may ask the contractor to de-silt the sewer line or clean the sewer line again for satisfactorily carrying out the work.

Notwithstanding the approval of the Engineer, the Contractor shall ensure that the equipment adopted shall be effective in cleaning sewers as specified without causing or precipitating (further) structural damage including collapse. Where the sewer is suspected to be in poor structural condition, the contractor shall ensure that cleaning operations cause no damage to the sewers at these locations.

Upon drying, the silt shall be immediately lifted from the site and transported to the designated place in an environmentally acceptable and safe manner.

Considering site constraints and traffic situations, the contractor may be allowed to stack the removed silt to temporary open land, if available, as per tender terms and condition with approval of the Engineer of the contract on specific request from the contractor with proper justification. The silt at the approved temporary site shall be dried for the period upto 48 hours and then transported to the designated dumping site within 24 hours. Necessary charges towards utilization of such open land will be borrowed by the contractor. Approved disinfectant shall be sprinkled on stacked silt.

All the risk and cost associated with safe disposal of the material taken out of the sewer shall be borne by the Contractor and nothing extra will be paid on this account in any circumstances.

2. Transportation of silt to the dumping ground

It shall be responsibility of the contractor to remove, transport and dispose off the dried silt to the dumping ground proposed by the contractor and approved by the Engineer. The procedure to be followed for dumping the silt is as under. All the vehicles used for transportation of silt shall be fitted with Vehicle Tracking System (VTS).

Before commencing de-silting operation, the contractor shall identify and propose dumping ground for accepting silt and submit a complete proposal including consent of

the concerned owner/authority of the dumping ground to accept silt, capacity of the dumping site, detail silt management plan, methodology for transportation and disposal of silt in safe and environment friendly manner, mode of disposal of silt at the proposed dumping site during the contract period, etc. for the approval of the Engineer of the Contract. The vehicles engaged for transportation of silt shall comply requisite RTO and BMC norms.

The contractor shall pay all the charges incidental to the removal, transportation and dumping of the silt to the dumping ground including silt levelling /tipping charges which may be levied by the said dumping ground per trip of the silt dumper or at lump sum, as the case may be. A challan will be issued by the site engineer of B.M.C. for each and every trip of dumper and the same shall be got acknowledged by the dumping ground authorities by the contractor. A copy of such acknowledged challan and VTS Report shall be submitted back for record to the site engineer. The contractor shall allow for all these costs in his rates. No extra payment on this account shall be admissible to the contractor.

3. Ventilation arrangement

The stretches of sewers where de-silting is to be carried out shall be well ventilated providing safe working conditions inside. The contractor shall operate heavy duty air blowers to ventilate sewers/confined space and to vent out foul gases from the sewers. The Contractor shall take all safety measures and precautions regarding working in confined space.

3.7. After de-silting CCTV survey Colour CCTV Survey using High-Definition CCTV equipment having pan, tilt and zoom facility including inspection of laterals and defects and provision of DVDs / Reports, etc. all with safety precautions and in environment friendly manner as per specifications and as directed.

3.7.1. General

The contractor shall carry out colour CCTV survey of each sewer line under this project, immediately after carrying out thorough de-silting of sewer line.

Before starting of the CCTV survey, the sewer line shall be cleaned satisfactorily so as to give clear view to CCTV camera head.

The CCTV survey shall be carried out in professional manner with a self-propelled camera having pan, tilt, zoom and auto measurement facility. All defects shall be recorded properly showing the exact meterage at which the defect exists and the date and time of recording, etc.

CCTV survey shall be carried out within three (3) days of cleaning. If CCTV survey works are delayed for a period in excess of three (3) days after cleaning, the sewer shall be re-cleaned, unless instructed otherwise by the Engineer. All costs associated with re-cleaning shall be borne by the Contractor.

The Colour CCTV inspection footages on a VCD/DVD and written reports in approved formats together with colour photographs of the host (existing) sewer shall be submitted to the Engineer.

CCTV video recordings shall be made from manhole to manhole. At every new manhole, the meter reading shall be set to zero. Interior of the manhole shall also be properly recorded during CCTV survey.

CCTV inspection will not be accepted when the height of water over the invert of sewer at the upstream manhole is more than 10% of internal diameter. In such cases the Contractor will have to take suitable measures for maintaining the water level below 10% of internal diameter.

3.7.2.Intent

The basic intent of the CCTV inspection is to carry out video recording of the internal condition of the sewer using remote controlled High Definition (HD) CCTV camera and to assess the condition of sewer on the basis of defects encountered and then to grade the sewer in accordance with the structural and service grades as defined under the Sewer Rehabilitation Manual of WRC, UK and arrive at the exact nature of measures needed for rehabilitation.

The output of the CCTV shall be free from distortion and shall illustrate all defects clearly. When photograph is extracted from the CCTV footage to depict a lateral or a specific defect, it shall occupy the central part of the photograph and be clearly in focus and accurately reflect the lateral or defect.

3.7.3. Defects Abbreviation

The abbreviations to be used in the Contract for classifying various types of defects shall be in accordance with the approved abbreviations by the Engineer. The abbreviations are based on Manual of Sewer Condition Classification by UK Water Industry Engineering and Operation Committee. The defects abbreviations are given in the Table below for reference.

Structural Defects		Service Defects	
Code	Definition	Code	Definition
B(J)	Broken pipe (at Joint)	DE(J)	Debris (at Joint)
CC(J)	Crack Circumferential (at Joint)	DEG	Debris Grease
CL(J)	Crack Longitudinal (at Joint)	DES	Debris Silt
CM(J)	Crack Multiple (at Joint)	EL(J)	Encrustation Light (at Joint)
D(H/V)	Deformation (Horiz/Vert.)	EM(J)	Encrustation Medium (atJoint)
DB	Displaced Bricks	EH(J)	Encrustation Heavy (at Joint)
FC(J)	Fracture Circumferential (Joint)	ESL	Scale Light
FL(J)	Fracture Longitudinal (Joint)	ESM	Scale Medium
FM(J)	Fracture Multiple (at Joint)	ESH	Scale Heavy
H	Hole in sewer	ID(J)	Infiltration Dripper (at Joint)
JDS	Joint Displaced Slight	IG(J)	Infiltration Gusher (at Joint)
JDM	Joint Displaced Medium	IR(J)	Infiltration Runner (at Joint)
JDL	Joint Displaced Large	IS(J)	Infiltration Seeper (at joint)
MB	Missing Bricks	OB(J)	Obstruction (at Joint)
MM	Mortar Missing Medium	RF(J)	Roots Fine (at Joint)
MS	Mortar Missing Surface	RM(J)	Roots Mass (at Joint)
MT	Mortar Missing Total	RT(J)	Roots Tap (at Joint)
OJM	Open Joint Medium	V	Vermin

OJL	Open Joint Large		
SSS	Surface Damage, palling Slight		
SSM	Surface Damage Spalling Med.		
SSL	Surface Damage, Spalling Large		
SWS	Surface Damage, Wear Slight		
SWM	Surface Damage, Wear Medium		
SWL	Surface Damage, Wear Large		
X	Sewer Collapsed		

3.7.4. CCTV Camera Speed

The speed of the CCTV camera in the sewer shall be limited to 9 to 12 m per minute or such other speed as agreed by the Engineer to enable all details to be extracted from the CCTV recording.

3.7.5. Variable Scan Camera

The Contractor shall provide colour pan and tilt camera(s) with zoom lens to facilitate the survey and inspection of all laterals. as well as other features, including defects such as hydrogen sulphide corrosion, missing or dislodged bricks, etc. in the overt of sewers and benching or walls of manholes. These will be carried out as part of the normal CCTV assessment as the survey or inspection proceeds when approved by the Engineer. A 360° rotational scan indicating general condition must be implemented at every 10-metre interval (min.) along sewers and at any salient defect features. The tilt arc shall not be less than 225° unless otherwise agreed.

The variable scan camera and colour monitor shall include screen graphics clearly indicating the directional location of the field of view of the sewer at any selected position relative to the cameras rotational and tilting arc. Zoom images shall similarly include reference to 'zoom' lens usage.

3.7.6. Linear Measurement

The CCTV monitor display shall incorporate an automatically updated record in metres up to two decimal fractions. The accuracy of linear measurement shall be 1% or 0.3 m whichever is less.

The Contractor shall demonstrate that the tolerance in the above Sub-clause is being complied with using one or both of the following methods in conjunction with a linear measurement audit form which shall be completed each day during the Survey:

- Use of a cable calibration device;
- Tape measurement of the surface between manholes.

If the Contractor fails to meet the required standard of accuracy the Engineer shall instruct the Contractor to provide a new device to measure the chainage. The Engineer may at his discretion instruct the Contractor in writing, to re-survey those lengths of sewer first inspected with the original measuring device using the new measuring device.

3.7.7. Data Display, Recording and Start of Survey/Inspection

At the start of each manhole length a data generator shall electronically generate and clearly display on the viewing monitor and recording a record of data in alpha-numeric form containing the following minimum information:

- Automatic update of the camera's chainage position in the sewer line from adjusted zero.
- Sewer dimensions
- Manhole/ pipe length reference numbers
- Date of survey
- Road name/location
- Direction of Survey
- Time of start of Survey

The size and position of the data display shall be such as not to interfere with the main subject of the picture.

Once the survey of the pipeline is under way, the following information shall be continually displayed:

- Automatic update of the camera's chainage position in the sewer line from adjusted zero.

- Manhole/ pipe length reference numbers
- Date of survey
- Time of start of Survey

3.7.8. Reverse Gradient

The contractor shall take invert levels of all manholes after de-silting and assess if any reverse gradient exists with respect to the ILs of consecutive manholes and shall clearly mark the said stretch(s) on topographical survey /GIS drawings and submittals in a method as approved by the Engineer.

3.7.9. Report Format

The contractor may use the Typical CCTV Survey Report Format accompanied as Annexure-I for submitting CCTV inspection report in hard copies. This shall be accompanied by DVDs for the inspection footage covered.

3.8. Local Repairs to Sewer Lines (For Non-man entry Sewer lines)

Local repairs for making good of badly deteriorated brick masonry/concrete sewer of any size and dislodged bricks, etc. grouting/sealing of cracks and joints, etc. all with safety precautions and in environment friendly manner as per specification and as directed.

(Quantity provision for approx. 20% of rehab sewer lines and 100% of non rehab sewer lines)

3.8.1. General

After de-silting of the sewer line, the contractor shall carry out local repairs to the sewer line which shall include cutting of roots intruding into the sewer line, arresting infiltration through joints, cracks, holes, etc. Everything required for carrying out local repairs and to prepare the internal surface of sewer for smooth passage of flow.

3.8.2. Removal of Mass Roots, Intruding Laterals, Concrete Grout and Other Obstructions

All mass roots, intruding laterals, concrete grout and other obstructions shall be neatly removed and the surface grinded to an acceptable finish. Other obstructions typically consist of, but are not restricted to, intrusion of steel bars, cables or timber etc that

are the result of construction or other activities, which result in the intrusion of such material through the sewer pipe. Care is to be taken to ensure that damage to the existing sewer body is minimised. All cutting/grinding activities are to be carried out under supervision of BMC site engineer.

The scope of works for the removal of mass roots, intruding laterals and other obstructions shall include firstly the grinding of the roots, lateral intrusion or other obstructions until the surface of the sewer pipe at the point of entry of the root, intruding lateral or other obstructions is fully exposed. The exposed surface shall then be grout to a depth of two thirds the thickness of the pipe wall. The recessed surface and any cracks or openings shall then be prepared by high Pressure water jetting. All prepared surfaces shall then be filled by the injection of an epoxy repair material. The final surface shall be smoothed to provide a hydraulically smooth finish.

The scope of works for the removal of concrete grout shall include the grinding down of the concrete grout until the surface of the sewer pipe is fully exposed. The exposed surface shall then be filled with an epoxy repair material and the final surface shall be smoothed to provide a hydraulically smooth finish. All surfaces shall be prepared by high pressure water jetting before the application of the epoxy filling material.

The length of repair for each removal of mass roots, intruding laterals, concrete grout or other obstructions shall extend a minimum additional length of 100 mm around the defect to enable the provision of a smooth transition between the repaired surface and the host pipe.

3.8.3. Removal of Heavy Grease Deposit, Encrustations/Crystallised Deposits in Sewers

All heavy/thick grease deposits and encrustations that cannot otherwise be removed by high pressure water jetting, either during sewer pre-conditioning or sewer cleaning immediately prior to local repairs shall be removed by an approved mechanical means. The proposed method(s) shall include the removal of hardened heavy/thick grease deposits and encrustations and/or crystallised deposits found on the inner surface of sewers.

3.8.4. Scope of Local Repairs (Not Applicable)

The crown portion of the sewer body is likely to be attacked (between 10 O'clock to 2 O'clock position) by hydrogen sulphide gas present in the sewer atmosphere.

The scope of local repairs includes removal of slime, grease, mass roots, encrustations, etc. from the sewer body, scrapping out of the loose/corroded concrete from the crown, plastering the crown portion between 10 O' clock to 2 O'clock wherever necessary using sulphate resistant cement mortar, replacing missing bricks/missing mortar, filling up of cavities, sealing of cracks, sealing of joints, sealing of water infiltration, etc. Any exposed reinforcement shall be wire brush cleaned and coated with a zinc rich epoxy primer.

The contractor shall use sulphate resistant cement mortar with the ratio 1:1 (cement: sand) by volume for plastering, filling up cavities, etc.

If ground water disturbs plastering or filling up of missing bricks, the fast-setting mortars shall be used.

If necessary unstable parts of the sewer shall be grouted for stabilization. The same will be done in areas where voids are detected during inspection.

For the local repairs consisting of all the above-mentioned activities like plastering of crown portion, replacing missing bricks/missing mortar, filling up of cavities with cement grout, sealing of cracks, sealing of joints, sealing of water infiltration, etc., the contractor shall quote per meter rate in the Bills of quantities.

No activity of the Contractor during preparation of the sewer for local repairs shall adversely affect existing structural integrity of the sewer.

3.8.5. Infiltration Control

The contractor shall adopt suitable techniques for minimizing the infiltration during the local repairs.

Minor infiltration shall be arrested using fast setting cement, Master sealing compounds, grouting or such other suitable material. Heavy infiltration/leakages of ground water into the sewer through opens joints, cracks, holes, etc. shall be arrested using chemical sealing compounds.

The contractor shall submit detail methodology of infiltration control including material proposed for leakage arresting, its chemical composition, make, brand, track record, etc. along with the bid.

3.9. Dimension Checking

This includes, dimensional check using Laser equipment or custom-made templates of various sizes through the sewer stretch of any size in order to decide the clear and best fit internal diameter of the parent sewer due to undulations, displacements at joints, ovality, etc., all with safety precautions and in environment friendly manner.

Dimension checking shall include the measurement of changes in horizontal and vertical alignment at changes in direction and bends where they occur between bends. Details shall be provided to the Engineer showing the results of the internal measurements.

3.10. Manhole Repairs

Manhole Repairs includes plastering, grouting and sealing of leaks and haunch repair, etc. including replacement of broken frames and cover, raising of buried manholes up to ground level, taking manhole coordinates with the help of rovers provided by BMC and updating data at SUMC, etc. all with safety precautions and in environment friendly manner as per specifications and as directed.

A separate B.O.Q. item is provided for repairing all existing manholes on the sewer lines under the scope of the work. Before commencing the repairs, the contractor shall study the existing conditions of manholes and temporarily divert all connections coming into the manhole and stop infiltrations into the manhole.

All the grease, slime, vegetation, foreign body and all cement plaster in the walls of the manhole shall be removed and the walls shall be thoroughly cleaned before commencing any repair work. The silt, debris shall be carefully collected at the manhole and removed from the site of the work and disposed off in an environmentally acceptable manner at the disposal site (dumping ground) as per the procedure mentioned in the specification.

The missing bricks in the walls shall be replaced with new bricks in the cement mortar 1:4, for bedding and benching repair work 1:4:8 cement concrete shall be used as specified and/ or as directed by the Engineer. The channel of the bed shall be flushed with invert of sewer line to facilitate smooth flow. The brick wall of the manhole shall

be plastered from inside with 20 mm thick cement (sulphate resistant) plaster in cement mortar 1:1. All incoming pipes/laterals in the manholes shall be properly finished.

All the Cast Iron (CI) steps weighing 5:44 kg each shall be supplied and replaced. The manhole frame and cover shall be removed, cleaned and painted with black epoxy/bitumen paint and installed properly so that it is seated evenly within the manhole frame and flushed with the road or ground level. The broken /damaged manhole covers and frames shall be replaced with new ones by the contractor. It is anticipated that approximately 10% of total manhole covers and frames under the scope of work will be required to be replaced with new ones. The contractor is required to allow for the same in his rates for repairs of manholes. The replaced broken old manhole covers and frames shall be returned to B.M.C. by the contractor. The type, design of manhole and manhole frame and cover shall be standard heavy duty type manholes, including heavy duty frame and covers as per B.M.C. standards. It is anticipated that approximately 10% of total manholes are buried under the road surface. If the manhole is buried, the same shall be raised upto the ground level. While raising the manhole, the profile of the manhole shall be maintained. If the shape is found to be distorted the same shall be rectified to restore the profile of manhole.

If it becomes necessary to break open the upper portion of the manhole for lowering installation machine into the sewer line during installation process, the entire cost for such breaking of upper portion of manhole and reinstatement of the same shall be allowed by the contractor in the rates quoted for this item of repairs of manholes. After repairing the manhole, the contractor shall collect data of repaired manholes and sewer line using the 'Manhole Record Sheet' provided under Annexure and update the same in the sewer database of SUMC at Dadar without any extra cost.

The cost for all the activities mentioned above shall be included in this item of repairs to manholes provided in the Bills of Quantities.

3.11. Construction of manholes

During the execution of work, if it is decided to construct a new manhole at a particular place from the point of view of facilitating future maintenance of sewer line

or it becomes necessary to construct a new manhole at a place where collapse is observed/pit is taken for accessing sewer line, then under similar situations, the contractor shall construct a new brick masonry conical manhole at a place so decided. A separate B.O.Q. item is provided for construction of new manhole. The manhole shall be constructed as per standard design of conical shape manholes followed in B.M.C. The construction of manhole shall include built in brick masonry in cement mortar 1:3, plastered both inside and outside with 20 mm thick cement mortar 1:2 and neat cement rendering so as to give a smooth surface, including 300 mm thick M15 cement concrete in foundation and in haunches and channels finished smooth with 20 mm thick cement plaster in cement mortar 1:1 and providing C.I. steps (weighing 5.41 kg each) staggered at 300 mm. c/c including 75 mm wide vata all-round the external portion of the manhole and the foundation concrete in cement mortar 1:1 and supporting the incoming pipes with brick masonry wherever necessary including C.I. extra heavy duty (EHD) air-tight circular frame & cover (minimum 230Kg.) with hinge / chain resting on 30 cm high cement concrete M20 cap with necessary centering etc. all complete as per standard specifications and directions including finishing the cap with cement plaster on both sides 1:2 and neat cement rendering so as to give a smooth surface in line and level with the brick masonry surface (Depth of Manhole measured from top of manhole cover to Invert level of manhole all with safety precautions and as directed The contractor shall use sulphate resistant cement for plastering of manhole, the cost of which is deemed to be included in the cost of construction of manhole.

4. Part 4 - Re-commissioning of Sewer Lines

On execution of work activities, the sewer line shall be re-commissioned by removing all coffer dams, pardsis constructed, stoppers, diversions, temporary pumping arrangements, etc.

All the other sewer lines and storm water drains used for temporary diversion of sewage flow shall be made good by the contractor at no extra cost.

The sewer shall not be re-commissioned until the Engineer has granted permission. The Engineer will retain the colour CCTV disks/Compact disks and pre and post photographs of the works.

5. Part 5 - Guidelines for Safe Entry and Working inside Sewers

5.1. Introduction

These general guidelines are intended to assist the Contractor in the development of safe work practices. Where the risk assessment indicates that a particular hazard cannot be present, the precautions to control that hazard do not apply. Remember that a favourable history does not guarantee absence of hazard on this occasion.

5.2. Confined Space

“Confined space”, in relation to a place of work, means a space of any volume which a person may at any time enter or be allowed to be enter in which the atmosphere is liable at any time to be oxygen deficient. This includes but not limited to pipes, sewers, manholes, tunnels, shafts, ducts, other similar sewerage installations and etc.

The Contractor shall develop acceptable work practices and safe entry procedures based on the guidelines provided hereunder and the Corporations’ guidelines on safety precautions to be observed during sewer desilting work included in this specification and implemented on site.

5.3. Notification to Work in Confined Space

The Contractor shall obtain an entry permit from the Engineer for each occupancy of any confined space. The Contractor shall furnish all required details in an approved format to the Engineer for permission to work in confined space at least 24 hours prior to the entry. Where prolonged work is involved, the permit must be renewed for each shift. An incident which substantially alters the condition of a confined space entry requires immediate evacuation and reassessment of the condition. Copies of all entry permits relating to previous shift must be submitted to the Engineer immediately upon exit of the persons working in those shifts and in any case before further entry permits are sought. No new entry permits shall be issued unless proper record of exit by workmen from earlier shift is submitted to the Engineer’s representative.

5.4. Air Quality and Ventilation

Contaminant control and effective ventilation are major factors influencing air quality in a confined space while working in sewers/manhole. The ventilation must be

adequate to clear pre-existing contaminated air and maintain a respirable atmosphere during planned work. This ventilation may be permanently installed or portable equipment used for this task. For general ventilation, fresh air shall be supplied to the workplace. Within the sewer system this creates an environment which displaces contaminated air in the immediate vicinity.

Where a task generates atmospheric contaminants in a specific area, adequate local exhaust ventilation should be used to remove the contaminants. Where failure of the mechanical ventilation system would result in deterioration of air quality, the controls must be clearly tagged to prevent accidental interference and the ventilation system monitored while the confined space sewer/manhole is occupied. Self-Rescuers must be carried whenever failure of the ventilation system or changes in the working environment can create a contaminated atmosphere. The self-rescuer can be a self-contained breathing apparatus, oxygen self rescuer, or short duration self contained breathing apparatus, depending on the time taken to reach open air.

Note: Obtain occupational hygiene advice on the- selection or performance of ventilation system where this is not specified in the work practice.

5.5. Lighting

Any regularly accessed confined space sewer/manhole should be illuminated with electrical installation to appropriate Indian Standard or equivalent. Portable lighting may be used to supplement permanent lighting in the workplace. Temporary mains powered lighting installed for a task must comply with the requirements of appropriate Indian Standard. Miners' lamps, mounted on a safety helmet may be used as an alternative to a hand-held torch for personal illumination.

The possibility of a flammable atmosphere must be eliminated by isolation, cleaning, ventilation purging etc.

Where the confined space has been proclaimed as a flammable gas hazard area, all fixed and temporary electrical installation must comply with appropriate Indian standard. Torches and portable lights must comply with appropriate Indian standard.

Illumination standards are: -

- General Lighting: - 40 lux minimum, equivalent to a poorly lit room

- Stairway lighting: - 80 lux minimum
- Task Lighting: - 240 lux minimum (normal workshop requirements)

5.6. Equipment usage, Standards and Maintenance

All confined space safety equipment must meet established standards and be of appropriate design for the proposed usage. The equipment must be checked for visible damage and correct operation before each use. Preventative maintenance must be performed by trained, and where necessary, authorised persons at the intervals recommended by the equipment manufacturers. The Contractor shall submit to the Engineer evidence of such periodic check, Calibration and maintenance of the equipment used for confined space entry at every month during the first week of the month.

5.7. Room to Work

When the constricted volume of a worksite prevents normal work postures and tool movement, the need for special tools or frequent work rotation should be considered.

5.8. Control of Flooding

When a confined space is normally liquid filled, accidental return to service must be prevented by double isolation e.g. insertion of suitable blanking piece, plugging with inflatable plugs, temporary coffer dams as a second isolation in a manhole or other effective means.

5.9. Flow Control

Where a sewer is entered while flowing, rapid increase in flow must be prevented by use of stop logs. Isolation of pumping stations, weather watch and other means appropriate to the sewer catchment. Adequate communication with the person responsible for flow diversion must be maintained for the duration of the entry.

5.10. Drowning

Where deep or flowing water is present, use of personal flotation devices. Safety harness and lifeline, safety nets etc. as appropriate to prevent drowning.

5.11. Fire and Explosion

Adequate precautions must be taken to minimise the risk of fire or explosion when entering a confined space for any purpose during all activities of sewer desilting, CCTV inspection and condition assessment in particular during desilting of sewer and while working in manhole/sewer

5.12. Presence of Flammable Gas

The presence of flammable gas, flammable dust or the possibility of the presence of airborne substances in flammable quantities may create a hazardous Area. Care shall be taken by the authorised person to determine the presence of any such flammable situation in the confined space before entry. Smoking or lighting any cigarette or box matches in confined space shall be strictly prohibited. The flammable gases of concern are methane, digester gas, vapours from flammable liquid, and vapours and gases from trade waste discharges.

5.13. Manual Handling of Tools etc

Safe system of work should be followed to protect against fall of persons or objects and crush by moving or falling objects. Extra care is needed if normal manual handling gear is not available or confined space safety gear (Harness, Respirator) is worn.

5.14. Noise

Reverberation within a confined space can increase noise levels, especially if more than one person is working. Heavy duty hearing protection may be required. The Contractor must comply with the requirement of noise levels under Environmental Protection Act and Rules.

5.15. Vermin

All persons working in confined spaces should be aware of the health hazards presented by the presence of vermin. The presence of cockroaches etc does NOT indicate that the atmosphere is free of danger to health.

5.16. Standby and Communication

A member of the confined space work team is allocated the task of maintaining communication with the members inside the confined spaces. This task may be

rotated among the members of the team. The Standby person must be trained and be physically capable of providing the assistance and life support in an emergency and must have sufficient proficiency in Marathi, Hindi and English languages to promptly communicate information by radio or telephone when required.

While acting as stand-by, this person must not enter the confined space or leave the vicinity unless relieved from this duty. A standby person is needed for all confined space entries. The Safe System of Work must indicate the process for communication from the confined space to the standby, e.g. 2 way radios. 'Man down' alarm, line of sight etc.

5.17. Fitness Assessment

A periodic assessment of fitness, including cardiovascular and respiratory health, is required to ensure that all persons entering confined spaces, or acting as the stand-by person, can comply with the physical demands of the job, without risk to their health

5.18. Emergency Rescue and First Aid

No person shall enter any confined space, even in an emergency, without first ensuring all safety requirements have been met. A safety emergency plan may assist in a safe, speedy response in the event of an emergency.

All confined space work teams must be trained and equipped to sustain life and be able to summon emergency help. Provide first aid and assist emergency service personnel, if requested.

Rescue of persons apparently overcome by toxic gases in a sewer/manhole or other confined space must only be attempted by trained persons using supplied air breathing apparatus. Stabilisation of other injuries must be prioritised against the availability of breathable air.

5.19. Gas Detector

The Contractor shall engage an authorised person for gas monitoring and detection. This person shall be trained to operate and response test gas testing equipment and is authorised by management to perform the necessary tests to decide whether a confined space is fit to enter.

Gas testing can only be performed by persons trained in gas testing, using equipment appropriate for the anticipated contaminants. This person can perform other duties provided these do not conflict with the gas testing task.

5.20. Specialist Gas Detector

This person has technical qualifications and acceptable training to operate and response test gas testing equipment, including hydrocarbon detectors and detector tubes and assesses portable ventilation systems. He is authorised by management to carry out atmospheric testing to establish entry conditions for all confined space categories. He also performs tests to verify whether hot work is permitted in gas hazard areas. He shall ensure that the Gas Detector unit has been properly calibrated and fit to be used in the given circumstances.

5.21. Cleaning

Where possible, cleaning should be performed without entry to the confined space.

Particular attention should be given to the probability of releasing hydrogen sulphide when disturbing microbial active sludge and sediments which have accumulated in a confined space. Supplied air respiratory protection shall be worn where such residues exist and effective ventilation cannot be guaranteed. Continuous gas monitoring is required even when supplied air respirator protection is used.

Hose couplings should be designed to resist accidental dislodging or loosening. Both the operators and the standby person should be able to stop the flow of cleaning material into the confined space.

Hydro jetting must be performed according to the relevant regulations. Where chemical compound is used in within the confined space, the chemical compound should be classed in the Material Safety Data Sheets as non-irritant to respiratory system, eyes and skin. If this is not possible then appropriate respirator skin and eye protection must be worn. Substance specific air monitoring may be required.

5.22. Visitors

A visitor to a confined space is a person other than a contractor, who is not a member of the Confined Space Work team. Visitors must be escorted and trained or inducted in

the necessary skills for that entry and shall sign an indemnity form before entry into a confined space.

5.23. Hazard Control

Hazards to be identified and controlled include but are not limited to: access. Mechanical and electrical isolation, flow isolation and control, drowning and engulfment, last known contents, atmospheric contaminants, temperature extremes, security and public access.

5.24. Definition

Parts Per Million (ppm)

Parts of gas or vapour per million parts of contaminated air by volume at 20°C and 1 bar pressure.

1 ppm = 0.0001%

Percentage

Parts of substance per 100 parts of air, water etc.

1 % = 10,000 ppm

5.25. Air Quality Standard for Entry

The acceptable limits of some gases in confined spaces are:

Gas/Vapour Present	Acceptable Limits
Oxygen Content (O ₂)	19.5% to 23.5% by volume
Flammable Gas/Vapour	5% of Lower Explosive Level (LEL)
Hydrogen Sulphide (H ₂ S)	10 Parts Per Million (ppm) Maximum (For Visitors) Reducing to 5 ppm for members of the public
Carbon Monoxide (CO)	30 Parts Per Million (ppm) Maximum Carbon Monoxide (CO) (For Visitors) Reducing to 10 ppm for members of the public.

5.26. Carbon Monoxide (CO)

Carbon monoxide is colourless. Odourless, flammable and toxic. Its common sources are fire, motor vehicle exhausts and cigarette smoke.

This gas is a chemical asphyxiant and is readily absorbed by the haemoglobin in the blood. Then haemoglobin is unable to transport oxygen to the body tissues and the body becomes oxygen starved. These effects are more pronounced with hard work or for heavy smokers. Symptoms include headache (50-200ppm), nausea (400ppm), and irregular heartbeat (1200ppm). Collapse and death (2000ppm).

The entry permit limit is 30 Parts per Million (ppm). Maximum with an IDLH value of 1500 ppm. The entry limit reduces to 10 ppm for members of the public. (IDLH- Immediately Dangerous to Life and Health)

Note: Some gas detecting machine sensors are cross sensitive, H2S being detected by the CO cell and vice versa. Alarm by either sensor requires evacuation and re-evaluation of the safe system of work.

5.27. Flammable Gas/ Vapour

A gas or vapour which will burn when mixed with air in certain proportions and ignited. The mixture which contains the least amount of flammable gases which will explode is called the Lower Explosive Limit (LEL) The mixture, which contains just enough Oxygen to let the flammable gas explode. Is called the Upper Explosive Limit (UEL). The flammable range varies for gases and vapours.

Many of these have toxic effects when inhaled and a Workplace Exposure Standard has been issued to protect workers from this Gas/Vapour. The Contractor shall obtain relevant Workplace Exposure Standard (WES) for use in the site.

Gas/ Vapour	Flammable Range in %	5% LEL	WES
Butane	1.9- 8.5	950ppm	800ppm
n-Hexane	1.2 -6.9	600ppm	50ppm
Methane	5-15	2500ppm	Axphyxiant
Petrol	1.3 - 6	650ppm	900mg/cum
Trichloroethylene	12.5 - 90	6259ppm	50ppm

5.28. Hydrogen Sulphide (H₂S)

Hydrogen sulphide is a colourless, toxic and flammable gas which usually has the odour of rotten eggs. In sewerage systems it is usually derived from the action of bacteria on the sulphur compounds in anaerobic or old sewage. A small amount of sludge or slime in wet wells or sewers will release a lot of H₂S when disturbed.

After a few minutes' exposure, the ability to smell hydrogen sulphide by a person is lost and then hydrogen sulphide becomes more dangerous as its presence is no longer obvious and the person could become an innocent victim.

It can sometimes be detected by odour at less than 0.1 ppm but can be readily detected by odour at 4ppm. More serious health effects include eye irritation (10ppm), respiratory irritation (50 ppm), headache, nausea, dizziness (200ppm), collapse and death (300ppm).

The entry permit limit is 10 Parts per Million (ppm), Maximum with an IDLH value of 300ppm. The entry permit reduces to 5 ppm for members of the public.

Note: Some gas detecting machine sensors are cross sensitive, H₂S being detected by the CO cell and vice versa. Alarm by either sensor requires evacuation and re-evaluation of the safe system of work.

5.29. Methane (CH₄)

The most common flammable gas found in sewers is methane. This mainly comes from gas pipe leaks in the city's gas distribution systems. It can also be derived from the action of anaerobic bacteria on rotting material. However, a range of other flammable gases and vapours may be encountered. These include LPG, petrol vapour and other solvents. Digester gas, found in anaerobic sludge digesters on sewage treatment plants is a flammable mixture of methane nitrogen and carbon dioxide.

Methane is a colourless, odourless gas. Although pure methane is slightly lighter than air. The relative density of methane/ air mixtures is similar to air in the entry permit range. Methane is hazardous because of its flammability, i.e. between concentrations of 5% to 15% in air, may explode if an ignition source is present. High concentrations of methane may result in oxygen deficiency. Injury or death results from lack of oxygen not methane toxicity classifying methane as a simple asphyxiant.

Note that the entry permits level is 5% of LEL, NOT 5% flammable gas.

5.30. Oxygen Content (O₂)

Fresh air contains about 20.9% oxygen.

In a confined space, oxygen can be used up by bacteria in sewage or sludge, rusting of iron fittings, burning (or welding) or displaced (pushed out) by other gases.

Breathing of air which contains reduced oxygen results in increasingly serious health effects. These range from impaired coordination and faulty judgement (12-16% O₂) to collapse and rapid death (less 6% O₂)

Increased oxygen readings can only come from instrument error or by leakage from oxygen cylinders, liquid oxygen tank, etc. High oxygen levels greatly increase fire hazards, fires burn fiercely; oily clothing and hair can catch fire without an ignition source.

The entry permit levels are 19.5% to 23.5 % by volume.

5.31. Other Atmospheric Contaminants

Entry, unless wearing air supplied breathing apparatus, is not permitted unless atmosphere contaminants are below the relevant 8 hour time weighted average (TWA) Workplace Exposure Standard. This limit applies for all entries including brief exposures. Entry wearing breathing apparatus is only permitted where the concentration of the contaminant is within the protection factor of the breathing apparatus and below the IDLH (Immediately Dangerous to Life & Health) value.

5.32. Sewer Gases

Air in contact with live sewage contains gases released from the sewer. For safe entry, contaminated air must be replaced with clean air by ventilation of the confined space. The resulting atmosphere must be confirmed by gas testing.

Discharge of untreated wastes, e.g. hypo chlorites, electroplating effluent, acids may result in generation of chlorine, hydrogen cyanide and other harmful gases some distance from the original discharge.

5.33. Confined Space Categorisation

The confined space category is a guide to developing a safe system of work. The confined space category may change to a more stringent level as a result of adverse environmental factors or work produced contaminants. Alternatively, it may change to a less restrictive category if appropriate engineering upgrades, whether temporary or permanent, are implemented.

Category 1 - Confined Space

Entry allowed only if flammable gas is below 5% of L.E.L. and other gases are within the protection factor of the respiratory protective equipment used.

Visibility must be adequate

Personal Safety

- Wear specified protective clothing for the hazards
- Wear safety harness
- Use lifeline where appropriate

Respiratory Protection

- Test air quality prior to entry by a Specialist Gas Detector
- Ventilate to reduce contamination
- Monitor air quality as directed by the Specialist Gas Detector
- wear airline breathing apparatus with backup air supply OR wear self contained breathing apparatus

Note: Oxygen self rescuer is not a backup for an airline used in contaminated atmospheres.

If the Category 1 confined space is a chemical storage tank, it can be reclassified to a Category 2 or 3 confined space when the Specialist Gas Detector confirms that the chemical has been cleared from the interior.

Sewer, wet wells etc can be reclassified by a Specialist Gas Detector to a lesser confined space only when an approved safe system of work is employed. This safe

system of work must provide for demonstrated control of airborne contaminants and other hazards in the workplace, to provide conditions equivalent to a category 2

Hot work requires control of fire and explosion hazards and may require air supplied breathing apparatus to control fumes irrespective of the confined space category. A Hot work permit is required in addition to the normal entry permit.

Category 2 - Confined Space

Entry allowed only if all gases are within entry permit limits

Personal Safety

- Wear specified protective clothing for the hazards
- Wear safety harness
- Use lifeline where appropriate

Respiratory Protection

- Test air quality prior to entry
- If air quality test fails refuse entry until reason found and rectified, or revert to Category 1 entry conditions.
- Ensure adequate ventilation
- Monitor air quality during entry
- Carry oxygen self rescuer

Note: Standby person must have SCBA readily available.

Hot work requires control of fire and explosion. Hazards and may require air supplied breathing apparatus to control fumes irrespective of the confined space category. A Hot work permit is required in addition to the normal entry permit. A hydrocarbon checks by a 'specialist gas detector' is required unless the environment can be upgraded to Category 3 conditions.

Category 3 - Confined Space

Entry permit required (unless using a posted entry procedure for routine operation of the facility) for each shift that the structure be occupied.

Personal Safety

- wear protective clothing specified for the hazards

Respiratory Protection

- test air quality prior to entry
- If the proposed work can generate airborne contaminants, arrange ventilation. Respiratory protection and/or air quality monitoring as appropriate.
- Hot work requires hot work permit and control of fumes.
- If air quality test fails, revert to Category 1 entry conditions or refuse entry until reasons found and rectified.

Category 4 - Confined Space

Follow facility safety procedures.

Personal Safety

- Wear protective clothing specified for the hazards

Respiratory Protection

- Evacuate when alarms advise
- Hot work requires control of fumes.

Separate Permit(s) required for chemical cleaning and/ or Hot Work. If evacuation alarm sounds, evacuate following site emergency procedure. Reoccupy as a Category 2 confined space.

5.34. Generic Entry Summary

	Category 1	Category 2	Category 3	Category 4
Entry Permit	yes	yes	yes	yes
Standby Person	yes	yes	yes*	yes*
Communication to remote standby	yes		yes*	
Protective Clothing	yes*	yes*	yes*	yes*

Safety Harness	Yes	yes		
Lifeline/Fall arrester	Yes	yes		
SCBA	yes*	#		
Airline and backup	yes*			
OSR	yes*	yes*		
Specialist gas tester	Yes			
Gas tester		yes	yes	yes
Gas monitoring		yes		
Ventilation	yes*	yes*	yes	yes

*Appropriate choice given in Safe Work practice for the task

Required by Standby Person

5.35. Confined Space Entry Permit Format

A general entry permit for working in sewerage works is given in 'Annexure I ' as an example. The Contractor shall develop his own format of the entry permit form and submit it for the approval of Engineer

5.36. Maintenance of Equipment

Any safety equipment, tool, gadget or machine for use on site must be maintained as per manufacturer's recommendation and records kept of this maintenance. The Safety Officer/engineer shall check the equipment to be used and certify it fit for use every time it is used on site.

Compressed air bottles must be refilled by a source which warrants that the air meets quality standards of BIS/AS or equivalent

Air from air compressors must be treated to meet quality standards of BIS/AS and tested periodically to demonstrate compliance.

All respiratory protection systems must be used in accordance with BIS/AS or equivalent.

5.37. Gas Detector Equipment

The Instrument must be operated according to the manufacturer's instructions.

The instrument must be checked for correct functioning using a test gas ('Response Check') every day when the instrument is used to check possibly contaminated atmospheres.

If the instrument is used less frequently, it can be response checked each time it is used.

The instruments must be calibrated at regular intervals according to the manufacturer's specifications.

It shall be the responsibility of the safety officer/engineer to ensure that the Gas Detector Equipment is in perfect working condition and providing accurate readings representing the atmosphere it is required to be used.

5.38. Standards

The following equipment must meet the relevant section of AS1716 or any equivalent standard

- a. Self-contained breathing apparatus
- b. Oxygen Set (Rescuer)
- c. Airline compressed air breathing apparatus

All workmen should use all the same-model of this equipment for interchange ability.

Obtain professional advice for selection of airline breathing apparatus and compressed air self rescuers.

Portable gas detection instruments must meet the following requirements

Sr. No.	Gas Monitored	Range Required	Resolution Required
1	Oxygen	1% - 30%	1 %
2	Flammable Gas	1% - 100% of LEL	1% of LEL
3	Hydrogen Sulphide	1 - 50 ppm	1 ppm
4	Carbon. Monoxide	1 - 400 ppm	1 ppm

5.39. Safety Procedures and Precautions

(To be taken during desilting, CCTV inspection and condition assessment works as well as installation and testing procedures as per standing guidelines of BMC)

1. Before opening any manholes, the stretch shall be properly barricaded and isolated in accordance with the safety requirements and the permission issued by the traffic police. The workmen on ground shall be provided with reflective safety jackets and a person shall be positioned to guide the traffic in vicinity of the work site to prevent any traffic accident involving the workmen or third party. To begin with the work of desilting, initially six consecutive manholes are to be opened, two on the upstream and two on the downstream side of the two manholes, on the actual stretch to be cleaned or desilted. The manholes should be kept open for one hour prior to the starting of cleansing operations and should be so kept open during the whole duration of cleaning operations. This to be done for allowing the combustible gases to escape naturally. No lighted match sticks should be thrown in the manhole. This may cause fire and explosions endangering the life of the workmen and the pedestrians. This may also damage to the sewer and other adjoining utility services, if any.
2. Jalis (safety screens) should be placed over all the opened manholes to prevent pedestrians etc., from falling in. Tripod stands with flags painted red should be placed over the manholes. The letters "Danger - Manhole Open" should be written in white reflective paint on the red background.
3. When working at night, lantern fitted with red globe and lights shall be placed with a temporary cover over the manhole, so that top of the cover is flush with the road surface. The covers shall be provided by the contractor without any extra cost. The same should be removed and replaced with regular manhole cover when the work is closed after ensuring that every worker entering the manhole/sewer has come out of the same.
4. The Contractor should keep sufficient number measurement rods. The measurement rods shall be made out of solid bamboo / M.S. rod of sufficient length fixed with M.S. flat 150 mm x 150 mm x 6 mm (6" x 6" and ¼") thick at one end and fitted with point at other end, to take measurement of water and silt.

5. Manholes shall be kept open for minimum one hour to allow foul gases to escape and simultaneously there should be forced purging with the help of an air blower to completely clean the air in the sewer.
6. Sewage levels shall be checked in the manholes and the same should not be more than 100mm (4") or 10% of height whichever is lower.
7. Wet lead acetate paper shall be inserted in the manholes which should not turn even light brown or black. If the lead acetate paper turns light brown or black, then the atmosphere inside manhole indicates the presence of Hydrogen Sulphide Gas (H₂S) and in that case this test shall be repeated after every ten minutes till positive result is achieved. The sensitivity of lead acetate papers should be ascertained to suit and detect the minimum allowable concentration (MAC) for long term exposure. This paper should be held as low as possible in the manhole atmosphere.
8. In spite of long waiting for about one and half hour, if the lead acetate paper continues to show negative result, air blower shall be used for half an hour. Thereafter gas detector shall be used to check the presence of gases and the worker shall be allowed only after it is confirmed by the Safety Officer/engineer in writing by issuing an Entry Permit that the condition insider the manhole is safe for man entry. Wherever necessary, or where the sewer line is heavily silted or there are chances of gas eruption, the person entering the manhole shall be provided with gas mask or breathing apparatus and hand blower or mechanical blower for use. Notwithstanding the lead acetate paper test or any other conventional tests use of gas monitor in working condition in every case is mandatory. The gas monitors should be accurately calibrated after regular intervals to maintain their reliability
9. After the lead acetate paper test, a lighted Davy's safety lamp shall be inserted in the manhole which should burn smoothly. If not, it shows the presence of Carbon monoxide (CO) and in that case precautionary measures as stated should be followed.
10. After the presence of combustible gases is ruled out, further test is required to be carried out for the presence of oxygen.
11. lighted naked candle placed at the centre of the candle testing equipment covered with glass on three sides should be lowered down slowly. If the flame is extinguished

or flickers, it indicates the presence of carbon – monoxide and or carbon dioxide. If it burns for not less than five minutes uniformly, it indicates the presence of oxygen which is required for breathing for the workman working inside the manhole.

12. **Working inside the Manhole**

After all these tests are carried out successfully, particular care should be taken where sewer is heavily silted that scum and sullage thoroughly stirred and disturbed by means of long bamboos / G.I. Rod from the top of the manhole to allow entrapped gases within silt pockets to escape before allowing the labourers to enter into the manhole.

The depth of water should be measured and the labourer should be allowed to enter the manhole only when the level of water is less than 100 mm (4”).

Before the labourer is allowed to get down inside the manhole, he should be asked to apply barrier creams all over the body as a precautionary measure to safeguard against itching and burning sensation. Safety belt/ harness with sturdy rope should be tied around his waist and chest when the labourers getting down, another man at the top should hold the other end of the rope which is tied to the harness of the labourers getting down / going down the manhole.

Not less than two people should be allowed to work inside the manhole at a time. Working alone in manhole/confined space shall not be permitted under any circumstances. They should always be sent in pairs. The labourers should not be asked to work for more than one hour at a time inside the manhole. If the work has to go on continuously, another pair of labourers should be asked to get down after the one-hour period of the earlier pair.

If the labourers who are working inside the manhole show even light discomfort, they should be asked to come up or pulled up. The labourers who are working inside the manhole should given jerks very few minutes to signify that everything is okay with them. A safely secured winch pulley system shall be provided for the worker to get down the manhole or for pulling out the workers.

After getting satisfactory test result and after taking precautionary measures as stated above and issue of safety permit and certification by the Safety Officer/engineer, the

worker shall be allowed to descend or enter in the manhole using winch pulley system/ aluminum ladder of adequate strength and approved type providing access to the bottom of the manhole. The worker shall wear personal protective gear before working inside the manhole. The workers entering the manhole shall be provided with wadder suit, hand gloves protective head gears, gumboots, abrasion resistant gloves, safety goggle, head lamp etc.

It should be remembered that in spite of the manhole entry tests being carried out, there are chances of eruption of poisonous gases in the silt and the safety officer/engineer shall properly brief the workman working in confined spaces on such issues and ways to overcome any emergency situations. If the worker finds any difficulty in breathing initially or during the work then he should be taken out immediately by means of harness belt. Where the sewer line is heavily silted or there are chances of gas eruption, gas mask must be used while entering the manhole and also during de-silting.

If the worker inside the manhole requires any instrument, the same should be tied to rope and lowered slowly inside the manhole ensuring the safety of the worker working inside the manhole.

13. On completion of the work, prior to closing of the manhole, the supervisor shall make sure to count the number of workers to ensure that all of the workers who went down the manhole have come out and no worker is left inside the manhole/sewer. The name of all workers shall be tallied with those in the entry permit form and shall be signed by the supervisor prior to submitting the same to the Engineer.
14. On completion of the work, all manholes shall be checked and it should be ascertained that all tools or equipment are removed from the manholes the same are properly closed
15. The workers emerging out of work inside the manholes and sewer shall be provided with bathing facilities for their hygiene. As necessary health check up shall also be arranged for the workers.

5.40. Scheme for Safety Measures and Welfare of the Workers (Engaged by BMC and its Contractors or sub-contractors)

1. Scheme prepared by BMC for Safety measure and welfare of the workers engaged by the Brihanmumbai Municipal Corporation (BMC) or by its contractors engaged for desilting, cleaning and repairs of sewer lines and associated works has been approved by the Bench of Mumbai High Court. The Contractor must follow the scheme for the safety and welfare of the workers engaged. The Contractor is deemed to have read and fully understood the requirements and obligations and made necessary provision in the contract price for the full compliance of the requirements.
2. The bidders shall obtain a copy of the scheme from the office of Dy.Ch.E. (S.O.) P&C, and follow the same scrupulously. The Contractor's safety officer/engineer and project manager shall be wholly and solely responsible for compliance with the directives/guidelines.
3. Notwithstanding the conditions incorporated by the Corporation in the bid, the Contractor shall obtain his own copy of the scheme and ensure that he complies fully with the statutory requirements. A suitable penalty shall be imposed on the Contractor for noncompliance of the conditions related to health, safety and welfare of the workers and other conditions of the scheme. Under no circumstances the contractors shall be allowed to start the work of cleaning and / or desilting and/or repairs including CCTV inspection and Condition assessment of the sewer lines / manholes, until the requisite insurance cover involving all risks and the workmen and third party are obtained and kept alive by the Contractor and accepted by the Engineer and verified by the Engineer and safety measures are adopted on site. Senior Officers of BMC will also verify during their periodical inspections that proper safety procedures are followed and record is maintained and the various conditions related to safety and welfare of the workers is fully complied with. As necessary periodic mock drills shall also be carried out for the work crew under the guidance of the project manager /safety officer/engineer.
4. Whenever the work of cleaning and/or desilting the sewer lines are entrusted to private contractors/ sub-contractors, such contractors shall be required to strictly observe all the conditions set out in the scheme. In case of deployment of sub-

contractors for desilting/ cleaning purpose, the main contractor shall duly notify the Engineer about the subcontractor and obtain prior approval for deployment of such sub-contractor; notwithstanding the other requirements about sub-contracting. However, the main contractor shall stand solely responsible for the safety of the works/ site.

5. Copy of the safety measures in either Marathi or Hindi language or the mother tongue of the workmen shall be given to each worker and also read out to them by the Supervisor/ Safety Officer of Contractors and explained to them
6. Non-compliance of the scheme for safety and welfare of the workers shall amount to contempt of court and the Contractor shall be liable to face any penal action in this respect in addition to usual penalty as per G.C.C. The amount paid towards compensation to the workers of the contractors shall be recovered from the Contractor through his running bills or any other deposits held with BMC.

5.41. Safety (General)

1. Proper ventilation shall be maintained in the manhole and sewer line being desilted. Mechanical blower should be preferably used for half an hour to one hour before entering the sewer line even after getting the safe working condition, while desilting sewer lines where accumulation of silt is heavy. The blowers shall be operated continuously during the desilting of sewer lines which are heavily silted or susceptible to gas generation.
2. While carrying out desilting, if required by the Engineer or the site conditions, the contractors shall use blower during the entire period. This would not only ensure safe condition but also ensure comfortable working condition for the worker and would in turn increase his performance and output.
3. In some manholes where sewage is falling over workman or causing obstruction, plugging the upstream sewers will be allowed temporarily without any cost to the corporation, provided the Contractor ensures that the upstream sewer line does not overflow. The plugs shall be removed by the Contractor at his risk and cost immediately after the work has been completed.
4. The Contractor shall use mechanical process for cleaning and desilting of sewer lines.

5. A tentative list of various safety tools, overhauls and safety equipment is given and the Contractor is obliged to provide at least the minimum number of safety equipments as indicated therein. The Contractor shall ensure that all workmen are briefed on use of the personal safety equipment (PPE), safety tools and gadgets and they use the same without fail before entering the manhole, sewer (confined space) etc.
6. No worker of Contractor shall be allowed to enter into the manhole for cleaning and desilting the sewer lines unless all the safety tools, shackles and equipment are at site and the worker is equipped with personal safety equipment such as gumboot, wadder suit, headgear, head lamp, hand gloves and harness belt etc and the safety officer clears his entry in the manhole or sewer by issuing an entry permit.
7. The contractor should keep “fully replenished first aid box at the site of works”.
8. One dedicated vehicle with the safety equipment such as breathing apparatus, diver suit, air blower, escape set etc., shall be made available at each site where personnel are entering the manholes for desilting, CCTV inspection or condition assessment. The same vehicle shall have other facility such as first aid kit, provision for eye wash etc. This vehicle may be used as an ambulance van in case of an emergency or an accident. The driver of such vehicles shall be duly informed about emergency steps and nearest medical facilities/ hospitals and shall be provided with mobile phone and his number made known to each and every person working on site. Special precautions may be needed to prevent inhaling of toxic fumes/gases while stanking (temporary/permanent) etc.

5.42. Welfare of Workmen

1. No person below the age of 18 years shall be employed for carrying out cleaning and desilting work of the sewerage system / sewer lines.
2. Adequate safety measures shall be taken by the Contractors to protect the workers engaged for sewer cleaning and desilting works.
3. The Contractor should impart training to the supervisory staff regarding implementation of this scheme and of safety measures including rescue methods and the use of safety equipment. Such training programme should be repeated periodically. The safety officer shall periodically brief the workers and supervisors and

conduct mock drills to ensure that the staff working on site is ready to face any untoward situation.

4. The workman entrusted with the work task of sewer cleaning and desilting should have basic functional literacy.
5. A detailed medical checkup of all the workers must be immediately undertaken. This checkup should include a full clinical examination, proper blood tests, routine radiological tests, pulmonary functions test, a psychiatric evaluation and other specialized tests wherever necessary. Special emphasis must be given to the study of the respiratory system, the eyes and the skin problems.
6. Each worker engaged in cleaning and de-silting of the sewer lines / manholes, shall be medically examined once a year and shall not be engaged, if he is suffering from any of the diseases such as respiratory, skin, eye problems, infections, cardiovascular, spinal psychiatric nature etc. He should not be engaged for cleaning and de-silting work inside the manhole or sewer lines till he is cured.
7. Whether a person is suffering from any of the above-mentioned diseases or not shall be certified by any Municipal Doctor. Similarly, the contractors engaged in cleaning and de-silting operation, shall get their workers, employees medically examined and shall not employ any worker who is found to be suffering from any of the above-mentioned ailments. The Contractor shall submit with the BMC a certificate from a registered medical practitioner showing that the workers to be engaged for the said contract involving cleaning and desilting operation are not suffering from any of the above-mentioned ailments.
8. The workers should be provided with vaccination against certain diseases commonly prevalent among sewage workers due to the nature of their work.
9. First Aid Box properly stocked including washing bottle to wash skin and eyes, should be kept.
10. Proper arrangement should be made to get treatment expeditiously, including facilities for speedy admission and treatment in any nearby hospital to the work site.

11. The Contractors engaged by BMC for sewer cleaning desilting and repair work, should take out workmen insurance policy at contractor's cost (individual or group) for workers engaged by him for sewer cleaning and/or desilting or repairing.
12. The contractor shall maintain washing, drinking water and toilet facility at each Chowky. If no toilet is provided in the chowky, it should be so located that the public toilet is available within a distance of 300 m. The site Chowky should also be equipped with full first aid kit.
13. Contractor should provide carbolic soap at the rate of one cake for four days and washing soaps at the rate of one cake for four days for washing clothes that are used by workers. The workers should be asked to take bath after the work is over. In cold seasons i.e. November 15 to January 31st, Contractor should supply sufficient fire wood to workers for warming up after taking the bath.

5.43. Contractor's Responsibility towards Welfare of the Workmen

1. A responsible officer of the supervisory cadre (designated Safety Officer) of the contractor should be physically present at the site and he/she should ensure and document compliance of the guidelines under the scheme for measures of safety and welfare of the workers and entry worthiness in the manhole. He / She should remain physically present throughout the operation and the onus of compliance of these guidelines should lie on him/her.

A log book should be maintained by him/her for giving the date and time, the names of workers, place and other relevant particulars to stay in the manhole etc. The said official should hold a certificate of training from a Competent Body such as St. John's Ambulance Brigade, Loss Prevention Association of India, Mumbai Fire Brigade etc. of training in First Aid and Emergency measures. If the Engineer is not satisfied about the various requirements as per the scheme then the work should be stopped immediately.

2. List of the contractor's employees including their residential addresses, age etc. is required to be supplied by the Contractor in separate register.

3. If the contractor has engaged 20 or more labourers, then the contractor is required to be registered under the Contract Labour Act and Inter-State Migrate Labour Act, wherever applicable.
4. Contractors should abide by all the rules and regulations in respect of labour laws prescribed by the Government, Authorities and submit the returns etc.
5. The workmen compensation should be paid to the Contractor's employees as per the provisions of Workmen's Compensation Act.
6. Contractor should maintain a muster of all the labourer working at site and his supervisor should prepare a triplicate copy of the same specifying the persons getting down the manhole and send one copy to the site engineer and another copy along with a copy of entry permit to the assistant engineer or executive engineer who is in charge of works and third copy should be kept by the Contractor in his office for his record.
7. He should also take measurements along with the site Engineer of the silt removed immediately after the work is closed for the day and prepare the same measurement record in triplicate. The contractor should give one copy to site Engineer and he should send one copy to the Assistant engineer or Executive Engineer, the copy of both of these should reach the A.E. or E.E. on the next working day before 11 A.M. without any extra cost.
8. The Contractor shall also ensure that the silt removed from the sewer is transported within 24 hours to the Dumping ground or to the site as directed by the Engineer.
9. If the contractor fails to remove the silt within 24 hours the same will be removed by the Corporation at his risk and cost, after the contractor has been notified in writing.
10. The contractor should not make the silt storage depot etc., near the water gully.

If found that the contractor disregarded the above and caused blockage in the water gully, the Corporation will clean the gully at the risk and cost of the contractor. Contractors shall locate depots at places where the obstruction to traffic is least. Depots should not be made near to junctions or school and shall obtain the approval of the Engineer on the location of Depots.

All the silt removed from manholes near bus stop or junctions should be transported immediately to a place approved by the Engineer within 100 meters from the manhole and from there silt shall be transported and disposed off by the contractor as specified in the contract. No extra payment on this account will be made.

11. The contractor should sprinkle sufficient quantity of bleaching powder over the silt removed to prevent smell emanating from the silt.

No person other than the Contractor's workers should be allowed to go inside the manhole.

If it is found that any unauthorized person (including contractor's workers without valid entry permit) has entered the manhole and injured or died, the contractor will be solely and fully responsible for the consequences including damages etc. claimed by the person or his heirs.

12. No person other than the Contractor's workers should be allowed to go inside the manhole.

If it is found that any unauthorized person (including contractor's workers without valid entry permit) has entered the manhole and injured or died, the contractor will be solely and fully responsible for the consequences including damages etc. claimed by the person or his heirs.

13. Plugging/stanching etc., if required to be done for stopping the flow or diverting the flow and pumping out sewage to facilitate removal of the choke or for any other purpose connected with cleaning/desilting/CCTV inspection/condition assessment work shall be done by the contractor without any extra cost.

14. Even though the contractors take all the precautionary measures and by chance any workman is injured or dies due to negligence or otherwise the contractor will be responsible for the claims of damages by the workman or his heirs.

6. Part 6 - Payment Schedules

The following payment conditions shall be read along with GCC clause no. 12 - Payment, Tax & Claims.

The payment schedule for each item shall be as follows-

Item No.	Major Work Activities	Payment (in % of Quoted Price of the Item)
1	Temporary plugging of sewer line by construction of coffer dam	
	a. After successful construction of coffer dam on the sewer line under execution	50% At actual
	b. After removal of coffer dam upon successful completion of work of isolated sewer line	50% At Actual
2	Permanent plugging of sewer line by construction of brick wall pardi.	
	a. After successful construction of brick wall pardi in the sewer line under execution	50% At actual
	b. After removal of brick wall pardi upon successful completion of work of isolated sewer line	50% At Actual
3	Taking trenches for diversion of sewage flow	
	a. After successful diversion of sewage flow by taking trenches	50% At actual
	b. After successful reinstatement of trench and road surface	50% At Actual
4	Diversion of Sewage flow by pumping arrangement	
	a. After successful installation of the pumping / flow by-pass arrangement of the sewer line under execution.	50% At actual
	b. After complete de-silting and transportation of silt of the sewer line under execution.	50% At actual
5	De-silting and transportation of silt to dumping ground	
	After successful De-silting and transportation of silt to dumping ground.	100% At actual

6	After De-silting CCTV survey	
	After successful completion of CCTV Survey	100% At actual
7	Manhole Repairs	
	After successful repairs to manholes on sewer line under execution	100% At actual
8	Raising /Lowering of Manholes	
	After successful completion to Raising /Lowering of manholes on sewer line under execution	100% At actual
9	Replacement of manholes covers	
	After successful replacement of manhole cover on sewer line under execution	100% At actual

7. Part 7 – Penalty

Following penalties shall be applicable for not complying with the time schedule of the activities of the work as mentioned below.

Sr. No.	Penalty
1	The contract period includes a mobilisation period of 15 days. The contractor shall mobilise the resources, complete preparatory works and start desilting within the period of 15 days beyond which a penalty at rate of Rs.10,000/- per day shall be levied until completion of preparatory works.
2	Silt removed from sewer shall be lifted and transported to the designated dumping site within 03 days of removal from sewer line, failing which penalty of Rs.5000/- per day per instance shall be levied until lifting and transportation is done.
3	For not maintaining site records, penalty of Rs.5000/- per instance shall be levied.
4	For not following instruction/s, safety norms, penalty of Rs.5000/- per instance shall be levied.
5	For damaging Municipal property, penalty of Rs.5000/-per instant shall be levied in addition to making good of the damaged property at own cost of the contractor
6	For not restoring site within 10 days after completion of contract period, penalty of Rs. 5000/- per day shall be levied till restoration of site.

SELECTION OF MATERIAL

1. All materials brought on the site of work and meant to be used in the same, shall be the best of their respective kinds and to the approval of the Engineer. The Engineer or his representative will accept that the materials are really the best of their kinds, when it is proved beyond doubt that no better materials of the particular kind in question are available in the market.
2. The contractor shall obtain the approval of the Engineer of samples of all materials to be used in the works and shall deposit these samples with him before placing an order for the materials with the suppliers. The materials brought on the works shall conform in every respect to their approved samples. Fresh samples shall be deposited with the Engineer whenever the type or source of any material changes.
3. The contractor shall check each fresh consignment of materials as it is brought to the site of works to see that they conform in all respects to the Specifications of the samples approved by the Engineer, or both.
4. The Engineer will have the option to have any of the materials tested to find out whether they are in accordance with the Specifications and the Contractor will bear all expenses for such testing. All bills, vouchers and test certificates, which in the opinion of the Engineer or his representative are necessary to convince him as to the quality of the materials or their suitability shall be produced for his inspection when required.
5. Any materials that have not been found to conform to the specifications will be rejected forthwith and shall be removed from the site by the contractor at his own cost within 24 hours.
6. The Engineer shall have power to cause the Contractors to purchase and use such materials from any particular source, as may in his opinion be necessary for the proper execution of the work.
7. Notwithstanding the source, the sand shall be washed using sand washing machine before use.

SECTION 12

**FRAUD AND
CORRUPT PRACTICES**

FRAUD AND CORRUPT PRACTICES

- The Applicants and their respective officers, employees, agents and advisers shall observe the highest standard of ethics during the Bidding Process. Notwithstanding anything to the contrary contained herein, the Authority may reject an application without being liable in any manner whatsoever to the Applicant if it determines that the Applicant has, directly or indirectly or through an agent, engaged in corrupt practice, fraudulent practice, coercive practice, undesirable practice or restrictive practice in the Bidding Process.
- Without prejudice to the rights of the Authority under relevant Clause hereinabove, if an Applicant is found by the Authority to have directly or indirectly or through an agent, engaged or indulged in any corrupt practice, fraudulent practice, coercive practice, undesirable practice or restrictive practice during the Bidding Process, such Applicant shall not be eligible to participate in any tender or RFQ issued by the Authority during a period of 2 (two) years from the date such Applicant is found by the Authority to have directly or indirectly or through an agent, engaged or indulged in any corrupt practice, fraudulent practice, coercive practice, undesirable practice or restrictive practice, as the case may be.
- For the purposes of this Clause, the following terms shall have the meaning hereinafter respectively assigned to them:
 - A. **“corrupt practice”** means the offering, giving, receiving, or soliciting, directly or indirectly, of anything of value to influence the actions of any person connected with the Bidding Process (for avoidance of doubt, offering of employment to, or employing, or engaging in any manner whatsoever, directly or indirectly, any official of the Authority who is or has been associated in any manner, directly or indirectly, with the Bidding Process or the LOA or has dealt with matters concerning the Concession Agreement or arising there from, before or after the execution thereof, at any time prior to the expiry of one year from the date such official resigns or retires from or otherwise ceases to be in the service of the Authority, shall be deemed to constitute influencing the actions of a person connected with the Bidding Process); **or**

save and except as permitted under the relevant sub clause, engaging in any manner whatsoever, whether during the Bidding Process or after the issue of the LOA or after the execution of the Concession Agreement, as the case may be, any person in respect of any matter relating to the Project or the LOA or the Concession Agreement, who at any time has been or is a legal, financial or technical adviser of the Authority in relation to any matter concerning the Project;

- B. “Fraudulent practice”** means a misrepresentation or omission of facts or suppression of facts or disclosure of incomplete facts, in order to influence the Bidding Process;
- C. “Coercive practice”** means impairing or harming or threatening to impair or harm, directly or indirectly, any person or property to influence any persons participation or action in the Bidding Process;
- D. “Undesirable practice”** means (i) establishing contact with any person connected with or employed or engaged by the Authority with the objective of canvassing, lobbying or in any manner influencing or attempting to influence the Bidding Process; or (ii) having a Conflict of Interest; and
- E. “Restrictive practice”** means forming a cartel or arriving at any understanding or arrangement among Applicants with the objective of restricting or manipulating a full and fair competition in the Bidding Process.
- F.** If the Employer/Financier determines that the Contractor has engaged in corrupt, fraudulent, collusive, coercive or obstructive practices, in competing for or in executing the Contract, then the Employer may, after giving 14 days’ notice to the Contractor, terminate the Contractor's employment under the Contract and expel him from the Site, and the provisions of relevant Clause shall apply as if such expulsion had been made.
- G.** Should any employee of the Contractor be determined to have engaged in corrupt, fraudulent, collusive, coercive, or obstructive practice during the execution of the Works, then that employee shall be removed in accordance with relevant Clause.

For the purposes of this Sub-Clause:

- i. "Corrupt practice" is the offering, giving, receiving to soliciting, directly or indirectly, of anything of value to influence improperly the actions of another party;
- ii. "Another party" refers to a public official acting in relation to the procurement process or contract execution. In this context, "public official" includes Financer staff and employees of other organizations taking or reviewing procurement decisions.
- iii. "Fraudulent practice" is any act or omission, including a misrepresentation, that knowingly or recklessly misleads, or attempts to mislead, a party to obtain a financial or other benefit or to avoid an obligation;
- iv. "Collusive practice" is an arrangement between two or more parties designed to achieve an improper purpose, including to influence improperly the actions of another party;
- v. "Coercive practice" is impairing or harming, or threatening to impair or harm, directly or indirectly, any party or the property of the party to influence improperly the actions of a party;
- vi. "Obstructive practice" is deliberately destroying, falsifying, altering or concealing of evidence material to the investigation or making false statements to investigators in order to materially impede the Financier investigation into allegations of a corrupt, fraudulent, coercive or collusive practice; and/or threatening, harassing or intimidating any party to prevent it from disclosing its knowledge of matters relevant to the investigation or from pursuing the investigation; or
- vii. acts intended to materially impede the exercise of the Financer's inspection and audit rights provided.
- viii. "party" refers to a public official; the terms "benefit" and "obligation" relate to the procurement process or contract execution; and the "act or omission" is intended to influence the procurement process or contract execution.
- ix. "parties" refers to participants in the procurement process (including public officials) attempting to establish bid prices at artificial, non-competitive levels.
- x. a "party" refers to a participant in the procurement process or contract execution.

SECTION 13

PRE BID MEEING

PRE-BID MEETING

Pre-bid meeting of the interested parties shall be convened at the designated date, time and place. A maximum of three representatives of each Applicant shall be allowed to participate on production of authority letter from the Applicant.

During the course of Pre-bid meeting, the Applicants will be free to seek clarifications and make suggestions for consideration of the Authority. The Authority shall Endeavour to provide clarifications and such further information as it may, in its sole discretion, consider appropriate for facilitating a fair, transparent and competitive Bidding Process.

SECTION 14

LIST OF APPROVED BANKS

LIST OF APPROVED BANKS

1. The following Banks with their branches in Greater Mumbai and in suburbs and extended suburbs up to Virar and Kalyan have been approved only for the purpose of accepting Banker's guarantee from 1997-98 onwards until further instructions.
2. The Bankers Guarantee issued by branches of approved Banks beyond Kalyan and Virar can be accepted only if the said Banker's Guarantee is countersigned by the Manager of a branch of the same Bank, within the Mumbai Limit categorically endorsing thereon that said bankers Guarantee is binding on the endorsing Branch of the bank within Mumbai limits and is liable to be on forced against the said branch of the Bank in case of default by the contractor/supplier furnishing the bankers Guarantee.
3. **List of approved Banks: -**

A	S.B.I and its subsidiary Banks
1	State Bank of India.
2	State Bank of Bikaner & Jaipur.
3	State Bank of Hyderabad.
4	State Bank of Mysore.
5	State Bank of Patiyala.
6	State Bank of Saurashtra.
7	State Bank of Travankore.
B	Nationalized Banks
8	Allahabad Bank.
9	Andhra Bank.
10	Bank Of Baroda.
11	Bank Of India.
12	Bank Of Maharashtra.
13	Central Bank of India.
14	Dena Bank.
15	Indian Bank.
16	Indian Overseas Bank.
17	Oriental Bank of Commerce.
18	Punjab National Bank.

19	Punjab & Sindh Bank.
20	Syndicate Bank.
21	Union Bank of India.
22	United Bank of India.
23	UCO Bank.
24	Vijaya Bank.
24A	Corporation Bank.
C	Scheduled Commercial Banks
25	Bank Of Madura Ltd.
26	Bank Of Rajasthan Ltd.
27	Banaras State Bank Ltd.
28	Bharat Overseas Bank Ltd
29	Catholic Syrian Bank Ltd.
30	City Union Bank Ltd.
31	Development Credit Bank.
32	Dhanalakshmi Bank Ltd.
33	Federal Bank Ltd.
34	Indsind Bank Ltd.
35	I.C.I.C.I Banking Corporation Ltd.
36	Global Trust Bank Ltd.
37	Jammu & Kashmir Bank Ltd.
38	Karnataka Bank Ltd.
39	KarurVysya Bank Ltd.
40	Laxmi Vilas Bank Ltd.
41	Nedugundi Bank Ltd.
42	Ratnakar Bank Ltd.
43	Sangli Bank Ltd.
44	South Indian Bank Ltd.
45	S.B.I Corporation & Int Bank Ltd.
46	Tamilnadu Mercantile Bank Ltd.
47	United Western Bank Ltd.
48	Vysya Bank Ltd.
D	Schedule Urban Co-op Banks

49	Abhyudaya Co-op Bank Ltd.
50	Bassein Catholic Co-op Bank Ltd.
51	Bharat Co-op Bank Ltd.
52	Bombay Mercantile Co-op Bank Ltd.
53	Cosmos Co-op Bank Ltd.
54	Greater Mumbai Co-op Bank Ltd.
55	Janata Sahakari Bank Ltd.
56	Mumbai District Central Co-op Bank Ltd.
57	Maharashtra State Co-op Bank Ltd.
58	New India Co-op Bank Ltd.
59	North Canara G.S.B. Co-op Bank Ltd.
60	Rupee Co-op Bank Ltd.
61	Sangli Urban Co-op Bank Ltd.
62	Saraswat Co-op Bank Ltd.
63	ShamraoVithal Co-op Bank Ltd.
64	Mahanagar Co-op Bank Ltd.
65	Citizen Bank Ltd.
66	Yes Bank Ltd.
E	Foreign Banks
67	ABM AMRO (N.Y.) Bank.
68	American Express Bank Ltd.
69	ANZ Grindlays Bank Ltd.
70	Bank Of America N.T. & S.A.
71	Bank Of Tokyo Ltd.
72	Bank indo suez.
73	Banque Nationale de Paris.
74	Barclays bank.
75	City Bank N.A.
76	Hongkong & Shanghai banking Corporation.
77	Mitsui Taiyokbe Bank Ltd.
78	Standard Chartered Bank.
79	Cho Hung Bank.

SECTION 15

APPENDIX

FORM OF TENDER

To,
The Municipal Commissioner for Greater Mumbai
Sir,

I/ We have read and examined the following documents relating to the work/supply
/construction of _____

- i. Notice inviting tender.
- ii. Directions to tenderers (General and special)
- iii. General condition of contract for Civil Works of the Municipal Corporation of Greater Mumbai as amended up to date.
- iv. Relevant drawings.
- v. Specifications.
- vi. Special directions
- vii. A to H
- viii. Bill of Quantities and Rates.

1A. I/We _____ (full name in capital letters, starting with surname), the Proprietor/ Managing Partner / Managing Director / Holder of the Business, for the establishment / firm / registered company, named herein below, do hereby offer to
.....
.....referred to in the specifications and schedule to the accompanying form of contract of the rates entered in the schedule of rates sent herewith and signed by me/us. (Strike out the portions which are not applicable).

1B. I/We do hereby state and declare that I/We, whose names are given herein below in details with the addresses, have not filled in this tender under any other name or under the name of any other establishment /firm or otherwise, nor are we in any way related or concerned with the establishment/firm or any other person, who have filled in the tender for the aforesaid work.

2. I/We hereby tender for the execution of the works referred to in the aforesaid documents, upon the terms and conditions, contained or referred to therein and in

accordance with the specification's designs, drawings and other relevant details in all respects.

* At the rates entered in the aforesaid Bill of Quantities and Rates.

3. According to your requirements for payment of Earnest Money amounting to Rs. _____
(Rs. _____)

I/We have deposited the amount through online payment gateways with the C.E. of the Corporation not to bear interest

4. I/We hereby request you not to enter into a contract with any other person/s for the execution of the works until notice of non/acceptance of this tender has first been communicated to me/us, and in consideration of yours agreeing to refrain from so doing I/we agree not to withdraw the offer constituted by this tender before the date of communication to me/us of such notice of non/acceptance, which date shall be not later than ten days from the date of the decision of the Standing Committee or Education Committee of the Corporation, as maybe required under the Mumbai Municipal Corporation Act, not to accept this tender.(Subject to condition 5 below).
5. I/We also agree to keep this tender open for acceptance for a period of 180 days from the date fixed for opening the same and not to make any modifications in its terms and conditions which are not acceptable to the Corporation.
6. I/We agree that the Corporation shall, without prejudice to any other right or remedy, be at liberty to forfeit the said earnest money absolutely, if.
- a. I/We fail to keep the tender open as aforesaid.
 - b. I/We fail to execute the formal contract or make the contract deposit when called upon to do so.
 - c. I/we do not commence the work on or before the date specified by the Engineer in his work order.
7. I/We hereby further agree to pay all the charges of whatsoever nature in connection with the preparation, stamping and execution of the said contract.
8. I/We further agree that, I/we shall register ourselves as 'Employer' with the Bombay Iron and Steel Labour Board' and fulfill all the obligatory provisions of Maharashtra Mathadi, Hamal and other Manual workers (Regulation of Employment and Welfare) Act 1969 and the Bombay Iron and Steel unprotected workers Scheme 1970.

9. "I/We..... have failed in the accompanying tender with full knowledge of liabilities and, therefore, we will not raise any objection or dispute in any manner relating to any action, including forfeiture of deposit and blacklisting, for giving any information, which is found to be incorrect and against the instructions and directions given in this tender.
10. "I/We further agree and undertake that in the event it is revealed subsequently after the allotment of work/contract to me/us, that any information given by me/us in this tender is false or incorrect, I/We shall compensate the Municipal Corporation of Greater Mumbai for any such losses or inconvenience caused to the Corporation in any manner and will not resist any claim for such compensation on any ground whatsoever. I/we agree and undertake that I/we shall not claim in such case any amount by way of damages or compensation for cancellation of the contract given to me/us or any work assigned to me/us or is withdrawn by the Corporation,"

Address

.....

Yours faithfully,

Digital Signature of the Tenderer or the Firm

1.....
 2.....
 3.....
 4.....
 5.....

Full Name and private residential address of all the partners constituting the Firm

1.
 2.
 3.
 4.
 5.

A/c No.

Name of Bank

Name of Branch

Vender No.

AGREEMENT FORM

Tender ID:

Standing Committee/Education Committee Resolution No.

CONTRACT FOR THE WORK / SUPPLY OF

.....
.....

This agreement made this day of Two thousand

..... Between

.....

.....

inhabitants of Mumbai, carrying on business at.....

.....in Bombay under the style

and name of Messrs

(Hereinafter called "the contractor of the one part and Shri

.....

..... the Deputy Municipal Commissioner

(Engineering) (hereinafter called "the commissioner" in which expression are included

unless the inclusion is inconsistent with the context, or meaning thereof, his successor or

successors for the time being holding the office of Deputy Municipal Commissioner

(Engineering) of the second part and the Municipal Corporation of Greater Mumbai

(hereinafter called "the Corporation") of the third part, WHEREAS the contractor has

tendered for the construction, completion and maintenance of the works described above

and his tender has been accepted by the Commissioner (with the approval of the Standing

Committee/Education Committee of the Corporation.

NOW THIS AGREEMENT WITNESSETH as follows: -

1. In this agreement words and expressions shall have the same meanings as are respectively assigned to them in the General Conditions of Contract for works hereinafter referred to:-

2. The following documents shall be deemed to form and be read and constructed as a part of this agreement viz.
 - a) The letter of Acceptance;
 - b) The Bid;
 - c) Addendum to Bid; if any
 - d) Tender Document
 - e) The Bill of Quantities:
 - f) The Specification:
 - g) Detailed Engineering Drawings
 - h) Standard General Conditions of Contracts (GCC)
 - i) All correspondence documents between bidder and BMC
3. In consideration of the payments to be made by the Commissioner to the contractor as hereinafter mentioned the contractor hereby covenants with the Commissioner to construct, complete and maintain the works in conformity in all respects with the provision of the contract.
4. The Commissioner hereby covenants to pay to the Contractor in consideration of the construction, completion and maintenance of the works the contract sum, at times and in the manner prescribed by the contract.

IN WITNESS WHERE OF the parties hereto have caused their respective common seals to be herein to affixed (or have hereunto set their respective hands and seals) the day and year above written.

Signed, Sealed and delivered by the
contractors

.....

.....
.....
In the presence of	Trading under the name and style of
.....
.....
Full Name & Address	Contractors

Signed by the D.M.C.(E) in the presence of Ex City/ WS/ ES

.....

D.M.C.(E)

The Common seal of the Municipal Corporation of Greater Mumbai was hereunto affixed on the 20in the presence of two members of the Standing Committee.

- | | |
|----|----|
| 1. | 1. |
| 2. | 2. |

And in the presence of the Municipal Secretary	Municipal Secretary
--	---------------------

ANNEXURE - A

Name of work /supply: Systematic Cleaning of Sewers of sizes 600mm and below in Eastern Suburb Area.

The Engineer for this work:

Chief Engineer.....Chief Engineer (Sewerage Operations)

Dy.Ch. EngineerDeputy Chief Engineer (Sewerage Operation)

Planning & Construction

Executive EngineerExecutive Engineer (Sewerage Operation)

Planning & Construction

1. Estimated cost of Tender: Rs 4,35,65,514.00
2. Earnest Money (1% of the Estimated cost) : Rs. 4,35,700/-
3. Time Period:

1.	Contract as a whole Period completion	06 Months (Excluding Monsoon)
2.	Part or Groups of items	
	i)	i)
	ii)	ii)
	iii)	iii)

4. Percentage to be charged as supervision charges for the work got executed through other means percent.

The "Actual cost of the work" shall mean in the case of percentage rate contracts the actual cost of the work executed at the rates as mentioned in the Contract Schedule adjusted by the Contractor's percentage rate and cost of extra and excess, but excluding the cost on account of Water Charges and Sewerage Charges if any, payable by the contractor and also

excluding cost on account of price variation claims as provided in price variation clause as amended up to date.

5. In case of item rate contracts, the actual cost calculated for the work executed at the rates mentioned in the contract schedule for different items including cost of excess and extra items of the work excluding the cost of water charges and sewerage charges if any, payable by the contractor and excluding cost on account of price variation claims as provided in extra excess conditions as amended up to date.
6. In case of lump sum contract the cost of the work actually carried out as per break up and programme of the work and the schedule of payment included in the contract including cost of any excess and/or extra items, of the work, excluding the cost on account of water charges and sewerage charges and also excluding cost on account of price variation claims as provided in extra excess conditions as amended up to date.

Annexure - B

PRE-CONTRACT INTEGRITY PACT

(On Rs. 500/- Stamp Paper)

The Bidder commits himself to take all measures necessary to prevent corrupt practices, unfair means and illegal activities during any stage of his bid or during any pre-contract or post-contract stage in order to secure the contract or in furtherance to secure it and in particular commits himself to the following: -

1. The Bidder will not offer, directly or through intermediaries, any bribe, gift, consideration, reward, favour, any material or immaterial benefit or other advantage, commission, fees, brokerage or inducement to any official of the BMC, connected directly or indirectly with the bidding process, or to any person, organization or third party related to the contract in exchange for any advantage in the bidding, evaluation, contracting and implementation of the Contract.
2. The Bidder further undertakes that he has not given, offered or promised to give, directly or indirectly any bribe, gift, consideration, reward, favour, any material or immaterial benefit or other advantage, commission, fees, brokerage or inducement to any official of the BMC or otherwise in procuring the Contract or forbearing to do or having done any act in relation to the obtaining or execution of the Contract or any other Contract with the Government for showing or forbearing to show favour or disfavour to any person in relation to the Contract or any other Contract with the Government.
3. The Bidder will not collude with other parties interested in the contract to impair the transparency, fairness and progress of the bidding process, bid evaluation, contracting and implementation of the contract.
4. The Bidder will not accept any advantage in exchange for any corrupt practice, unfair means and illegal activities.
5. The Bidder, either while presenting the bid or during pre-contract negotiations or before signing the contract, shall disclose any payments he has made, is committed to or intends to make to officials of the BMC or their family members, agents, brokers

or any other intermediaries in connection with the contract and the details of services agreed upon for such payments.

6. The Bidder shall not use improperly, for purposes of competition or personal gain, or pass on to others, any information provided by the BMC as part of the business relationship, regarding plans, technical proposals and business details, including information contained in any electronic data carrier. The Bidder also undertakes to exercise due and adequate care lest any such information is divulged.
7. The Bidder commits to refrain from giving any complaint directly or through any other manner without supporting it with full and verifiable facts.
8. The Bidder shall not instigate or cause to instigate any third person to commit any of the actions mentioned above.
9. The Bidder and their respective officers, employees, agents and advisers shall observe the highest standard of ethics during the Bidding Process. Notwithstanding anything to the contrary contained herein, the Authority may reject an application without being liable in any manner whatsoever to the Applicant if it determines that the Applicant has, directly or indirectly or through an agent, engaged in corrupt practice, fraudulent practice, coercive practice, undesirable practice or restrictive practice in the Bidding Process

For the purposes of this Clause 9, the following terms shall have the meaning herein after respectively assigned to them:

- i. "Fraudulent practice" means a misrepresentation or omission of facts or suppression of facts or disclosure of incomplete facts, in order to influence the Bidding Process;
- ii. "Coercive practice" means impairing or harming or threatening to impair or harm, directly or indirectly, any person or property to influence any persons participation or action in the Bidding Process;
- iii. "Undesirable practice" means (i) establishing contact with any person connected with or employed or engaged by the Authority with the objective of canvassing, lobbying or in any manner influencing or attempting to influence the Bidding Process; or (ii) having a Conflict of Interest; and

- iv. “Restrictive practice” means forming a cartel or arriving at any understanding or arrangement among Applicants with the objective of restricting or manipulating a full and fair competition in the Bidding Process.

Signature of Tenderer/Bidder

Annexure – C

DECLARATION CUM INDEMNITY BOND

(On Rs. 500/- Stamp Paper)

I, _____ of _____, do hereby declare and undertake as under.

- i. I declare that I have submitted certificates as required to Executive engineer (Monitoring) at the time of registration of my firm/company _____ and there is no change in the contents of the certificates that are submitted at the time of registration.
- ii. I declare that I _____ in capacity as Manager/Director/Partners/Proprietors of _____ has not been charged with any prohibitory and /or penal action such as banning (for specific time or permanent) / de-registration or any other action under the law by any Government and/or Semi Government and/or Government undertaking.
- iii. I declare that I have perused and examined the tender document including addendum, condition of contract, specifications, drawings, bill of quantity etc. forming part of tender and accordingly, I submit my offer to execute the work as per tender documents at the rates quoted by me in capacity as _____ of _____.
- iv. I further declare that if I am allotted the work and I failed to carry out the allotted work in accordance with the terms and conditions and within the time prescribed and specified, BMC is entitled to carry out the work allotted to me by any other means at my risk and cost, at any stage of the contract.
- v. I also declare that I will not claim any charge/damages/compensation for non availability of site for the contract work at any time.
- vi. I declare that I will positively make the arrangements of the required equipment on the day of commencement or with respect to the progress of the work in phases, as per the instructions of site in charge.

Signature of Tenderer/Bidder

BANKERS GURANTEE IN LIEU OF CONTRACT DEPOSIT

THIS INDENTURE made this _____ day of _____ BETWEEN THE _____ BANK incorporated under the English/Indian Companies Acts and carrying on business in Mumbai (hereinafter referred to as 'the bank' which expression shall be deemed to include its successors and assigns) of the first part _____ inhabitants carrying on business at _____ in Mumbai under the style and name of Messer's _____ (hereinafter referred to as 'the consultant') of the second part Shri. _____ THE MUNICIPAL COMMISSIONER FOR GREATER MUMBAI (hereinafter referred to as 'the commissioner' which expression shall be deemed, also to include his successor or successors for the time being in the said office of Municipal Commissioner) of the third part and THE MUNICIPAL CORPORATION OF GREATER MUMBAI (hereinafter referred to as 'the Corporation') of the fourth part WHEREAS the consultants have submitted to the Commissioner tender for the execution of the work of " _____ " and the terms of such tender /contract require that the consultants shall deposit with the Commissioner as/contract deposit/ earnest money and /or the security a sum of Rs. _____ (Rupees _____) AND WHEREAS if and when any such tender is accepted by the Commissioner, the contract to be entered into in furtherance thereof by the consultants will provide that such deposit shall remain with and be appropriated by the Commissioner towards the Security deposit to be taken under the contract and be redeemable by the consultants, if they shall duly and faithfully carry out the terms and provisions of such contract and shall duly satisfy all claims properly chargeable against them there under AND WHEREAS the consultants are constituents of the Bank and in order to facilitate the keeping of the accounts of the consultants, the Bank with the consent and concurrence of the consultants has requested the Commissioner to accept the undertaking of the Bank hereinafter contained, in place of the contractors depositing with the Commissioner the said sum as earnest money and /or security as aforesaid AND WHEREAS accordingly the Commissioner has agreed to accept such undertaking NOW THIS AGREEMENT WITNESSES that in consideration of the premises, the Bank at the request of the consultants (hereby testified) UNDERTAKES WITH the

commissioner to pay to the commissioner upon demand in writing , whenever required by him , from time to time , so to do , a sum not exceeding in the whole Rs._____ (Rupees _____) under the terms of the said tender and /or the contract .The B.G. Is valid up to _____” Notwithstanding anything what has been stated above, our liability under the above guarantee is restricted to Rs._____ only and guarantee shall remain in force up to _____ unless the demand or claim under this guarantee is made on us in writing on or before _____all your right under the above guarantee shall be forfeited and we shall be released from all liabilities under the guarantee thereafter”

IN WITNESS WHEREOF

WITNESS (1) Name and address	
WITNESS (2) Name and address	the duly constituted Attorney Manager
the Bank and the said Messer’s (Name of the Bank)		
WITNESS (1) Name and address	
WITNESS (2) Name and address	
For Messer’s Address	

have hereinto set their respective hands the day and year first above written.

The amount shall be inserted by the Guarantor, representing the Contract Deposit in Indian Rupees.

Annexure – D

Rate Analysis

Item Description:

Sr. No.	Description of rate analysis Parameters	Unit	Quantity	Rate	Amount
1	Basic Material (Rate should be inclusive of all taxes)				
2	Machinery Hire Charges				
3	Labour Type		(labour components)		
4	Total of all components				
5	Overhead & Profit 15% on 4				
6	Total Rate (4+5)				
7	Per unit rate				

Sign & Seal of the Tenderer

Annexure – E

Undertaking for best price

(As per circular u/no. DMC/CPD/OD/15 Dtd. 06.05.2013, to be uploaded in folder 'A')

(On stamp paper of Rs. 500/- duly notarized by notary with red seal and registration number)

Tender ID:

To,

The Municipal Commissioner

For the Municipal Corporation of Greater Mumbai

Sir,

"I / We (Full Name in capital letters starting with surname), the Proprietor / Managing Partner / Managing Director / Holder of the Business / Manufacturer / Authorized Dealer, for the establishment / firm / registered company , named herein below , do hereby , state and declare that I/We ----- whose names are given herein below in details with the addresses have not filled in this tender under any other name or under the name of any other establishment / firm or otherwise , nor are We in any way related or concerned with any establishment / firm or any other person , who have filled in the tender for the aforesaid work."

"I / We do hereby further undertake that; we have offered the best prices for the subject supply / work as per the present market rates. **Further, we do hereby undertake and commit that we have not offered / supplied the subject product / similar product / system or sub system in the past one year in the Maharashtra State for quantity variation upto - 50% or + 10 % at a price lower than that offered in the present tender to any other outside agencies including Govt. / Semi Govt. agencies and within the BMC also.** Further, we have filled in the accompanying tender with full knowledge of the above liabilities and therefore we will not raise any objection or dispute in any manner relating to any action, including forfeiture of deposit and blacklisting, for giving any information which is found to be incorrect and against the instructions and directions given in this behalf in this tender.

I / We further agree and undertake that in the event it is revealed subsequently after the allotment of work / contract to me / us , that any information given by me / us in this tender

is false or incorrect , I / We shall compensate the Municipal Corporation of Greater Mumbai for any such losses or inconvenience caused to the Corporation in any manner and will not resist any claim for such compensation on any ground whatsoever , I / We agree and undertake that I / We shall not claim in such case any amount , by way of damages or compensation for cancellation of the contract given to me / us or any work assigned to me / us or is withdrawn by the Corporation.”

However, in case of price difference, if it is a result of differential tax structures, different dollar value of Rupee, differential logistic of transport etc. Considering this aspect, before invoking the penalty, black-listing, I/We will be given a reasonable opportunity of being heard by representing our case as to why such price variation / differential has been arisen.

In case if the explanation submitted by me / us is unsatisfactory then action including forfeiture of despatch and black-listing may be taken against me/us.

Tenderer's full Signature with full name

& address with rubber stamp

Annexure - F

INFORMATION REGARDING STATUS OF BIDDER

(1) (a) Whether it is a proprietor concern -----
concern

(b) If so, name of the owner -----

(2) If it is a partnership concern, please -----
furnish name of each partner and copy -----
of registration certificate -----

(3) In case of company, please furnish -----
the documentary proof to show that -----
the company is registered. -----

(4) In case of Joint Venture, please -----
furnish the name of each firm and Joint -----
Venture forms. -----

Signature of authorized

Person of concern/company

Name of concern/company and seal

Annexure – G

TYPICAL CCTV SURVEY REPORT FORMAT

Project					
Name of the Road		Ward		Zone	
Sewer Line No		Upstream MH		Downstream MH	
Inspection Direction	In/ Against flow direction	Time of Start		Time of Completion	
CD No.		Name of CCTV Surveyor		Name of Supervisor	
Profile Shape	Circular/ Oval/ Rectangular	Width (mm)		Height (mm)	
Material of Construction	VC/ CO/ BR/ lining/ OTHER	Completion Plan no of BMC		Year of Construction	
Total Length Between End Points (m)		Surveyed length (m)		Depth @ u/s (m)	
				Depth @ d/s (m)	
Comment:					
Insp. Chainage	Time Code		Picture No	Description of Event	
00.00	230000		zzzz01	Start MH xxxxxxxx	
03.25	230200		zzzz02	Missing mortar @ 12 O Clock position	
11.45	230500		Zzzz03	Infiltration Gusher @ 40 Clock position	
30.10	232200		Zzzz04	MH yyyyyyyy reached	

Hard copy CCTV inspection sheets to be maintained for each stretch between consecutive manholes for known manholes. In case of buried manholes appropriate noting shall be made.

The inspection length may differ from the real length.

Surveyed By :

Contractor's representatives

Engineers Representatives

Annexure – H: TYPICAL MANHOLE RECORD SHEET (NIS SHEET)

Network Information Sheet (NIS) FOR MANHOLE										
Nature of Work :								NIS No :	(Office use only)	
Work carried on :	<input type="checkbox"/> MANHOLE	<input type="checkbox"/> RCM (Reconstruction)	<input type="checkbox"/> RTM (Repairs)	<input type="checkbox"/> RBM (Raising of buried)	<input type="checkbox"/> FMF (Fixing of Manhole Frame)	<input type="checkbox"/> FMC (Fixing of Manhole Cover)	<input type="checkbox"/> CNM (New Construction)	OTHER (please specify)		
	<input type="checkbox"/> CHAMBER	<input type="checkbox"/> RSL (Replacement/ Repairs)	<input type="checkbox"/> PSL (Providing and laying)	<input type="checkbox"/> ESL Enlargement	<input type="checkbox"/> PSLM (laying by microtunneling)	<input type="checkbox"/> MWSL (REHAB by MWSL)	<input type="checkbox"/> PBS (REHAB by Bursting)	OTHER (please specify)		
<input type="checkbox"/> SEWERLINE	2) Date of Completion/ Commissioning :			*Road Type :		<input type="checkbox"/> Concrete Road	<input type="checkbox"/> Paver Block Road			
1) Ward :						<input type="checkbox"/> Mastic	<input type="checkbox"/> Asphalt Road			
3) Road Name:										
4) Work Executing Agency:	Deptt. :			Contractor :						
5) P.O. NO				6) DLP <small>(Defect liability end date)(dd-mm-yyyy)</small>			*Status :	<input type="checkbox"/> Public	<input type="checkbox"/> Private	
7) Node : NODE NO :										
(I) Manhole :										
General	Manhole Depth (m)	* Manhole Shape		Cover Load Duty		Steps (Nos.)	*Const Code :			
		Conical	<input type="checkbox"/>	Light	<input type="checkbox"/>					
		Rectangular	<input type="checkbox"/>	Medium	<input type="checkbox"/>					
		Square	<input type="checkbox"/>	High	<input type="checkbox"/>					
Cover	Cover Dimensions (mm x mm)	*Cover Shape (C / R)		Hinged (Y/N)	Locked (Y/N)	Cover level (mTHD)	Catch Pit (Y/N) :			
		<input type="checkbox"/> Circular	<input type="checkbox"/> YES	<input type="checkbox"/> YES						
		<input type="checkbox"/> Rectangular	<input type="checkbox"/> NO	<input type="checkbox"/> NO						
						<input type="checkbox"/> YES				
						<input type="checkbox"/> NO				
(II) Incoming Pipe Details :										
Upstream Node Ref.(Node No/Private)	Connection Code Main(M)/ Street(P)	Pipe Shape Code <small>Circular-C Rectangular-R Square -S ARCH -A Barrel -B Egg/Ovoid -E</small>	Pipe Size (mm x mm)	* Material Code(VC/CO)	*Lining Material Code (UPVC/CIPP/GRP)	Depth from Cover (m)	Invert Level (mTHD)			
(III) Outgoing Pipe Details :										
Downstream Node Ref	Pipe Length (m)	*Pipe Shape Code	Pipe Size (mm x mm)	*Material Code	*Lining Material Code	Depth from Cover (m)	Invert Level (mTHD)			
(8) Cardinal Points :										
Point	Location / Landmark				Distance (m)					
1										
2										
3										
(9) Remarks / Additional Information:										
Contractor's Signature & Stamp					MCGM's authority's Signature & Stamp					

Annexure – I

CONFINED SPACE ENTRY PERMIT FORM

Date:

Project:			
Client:		Contractor:	
Zone/Ward:		Is a hot work permit required (Yes/No):	

Site and Task Information

Location of the Work		Stretch	
Upstream manhole No.		Downstream Manhole No.	
Name		Present (Y/N)	Signature
Contractor's Site Engineer: _____			
Contractor's Safety Officer/ Engineer _____			
Contractor's Site Supervisor: _____			
Description of the work for which entry permit is sought:			

Emergency Standby Vehicle Check

Activity	Detail	Checked/Present	Checked By (Name, Sign, Date)
Vehicle Registration No.			
PUC valid (till)			
Vehicle fuel level			

Vehicle running condition			
Driver's Name			
Driver's Mobile No.		Checked by calling	
Driver's License No.			
Driver instructed			
Nearest Hospital Details with Tel no.:			
<p>Driver must be instructed to be in the vehicle & be alert till the entire duration of the confined space activity.</p> <p>Driver must be instructed NOT to keep his mobile busy during the entire duration of the confined space activity.</p>			

Air Quality Checks

Gas Checked (safe limit)	Value	Checked At	Checked By (Name, Sign & Date)
Oxygen (19.5% to 23.5%)			
H ₂ S (max 10ppm)			
Flammable gases (max 5%LEL)			
Carbon Monoxide (max 30ppm)			
Others ()			
Ventilation System			
Response test date for Gas Monitor			
Monitor Occupied			
The values observed must be within safe limits during all the time while working in confined space			

Isolation of the Confined Space

Activity	Status (Y/N)	Checked by	Checked By (Name, Sign & Date)
Plugging			
Stanching			
Sewage Flow Control /Pumping			
Harmful Substance Present			
Warning Signs/Notices/ Appliances in place			
Manhole Opened at (Time)			
Manhole properly barricaded			

Chemical Checks

Chemicals to be used	Method of Application	Certified (Y/N)	Checked By (Name, Sign, Date)

Personnel Protective & Safety Equipment Checks

Equipment	Status (Y/N)	Quantity	Checked By (Name, Sign, Date)
Gas Monitor			
Gas mask			
Breathing Apparatus			
Safety harness with rope			
Safety Shoes			

Safety Helmet with lamp			
Abrasion resistant hand gloves, Nose Mask			
Protective Clothing			
Communication Device			
Winch Pulley System			
Rescue Equipment			
Ventilation Equipment			
Non-Spark Torch			
First Aid Kit with medicines			
Any Other			

Other Safety Measures Checks

Safety Measure	Status (Y/N)	Checked By (Name, Sign, Date)
Area properly barricaded		
Manhole Jalis Provided		
Work in progress and other warning Signs		
No Smoking Warnings		
Any other		

Confined Space Entry Workers Information

Persons seeking entry into confined space			
Total number of persons (In words & numeral)		Tentative duration of stay in confined space	
Checked Vaccination status of all workers entering in confined space (YES/NO)			

Sr. No.	Name	Age (yrs)	Medically Fit (Yes/No)	Time of Entry	Time of Exit	Vaccination status	Emergency Contact No.

WORKER MUST NOT be allowed to enter in the confined space without validating Vaccination status.
No underage person shall be permitted to work on site under any circumstances.

Attendance:

Client's Representative (Name & Signature)	Contractor's Representative (Name & Signature)

This is to certify that the team entering in confined space is trained & briefed to work in the confined space and this confined space is safe for entry and carrying out of the task.

Supervisor (Name, Signature & time)	Safety Officer (Name, Signature Date & time)

Work closure checks	
All equipment/ tools removed (YES/ NO)	
Obstructions removed and Flows restored (YES/ NO). If no; pl record reasons	
Manhole covers properly replaced and manholes securely closed (YES/ NO). If no; pl record reasons and measures taken for preventing mishap	
Site cleaned/ cleared (YES/ NO)	

This is to certify that all the persons entered in the confined space have come out of the confined space as of _____ (time) and no further entry is required at this point of time.

Supervisor (Name, Signature & time)	Safety Officer (Name, Signature, Date & time)

Has any Event(s)/Emergency(s) occurred (Yes/No)	
If "YES" then, Nature of Event(s)/Emergency(s):	
Supervisor (Name, Signature & time)	Safety Officer (Name, Signature, Date & time)

NOTE: Confined Space Entry permit shall be maintained on site with the Contractor and the Engineer's representative. Copy of this entry permit shall be sent to the Engineer electronically before commencement of the next day.

Annexure – J

MUNICIPAL CORPORATION OF GREATER MUMBAI

CIRCULAR U/No. MGC/F/6342 dated 5.5.2018

Sub: Revised guidelines regarding barricades being used during the execution of various infrastructure development projects by BMC in Mumbai.

Various infrastructure development projects are being executed by BMC for the betterment of citizens of Mumbai. During the course of execution of the projects, it is necessary to provide strong and secured barricading as a safety measure to avoid any mishaps as well as to avoid nuisance to vehicular and pedestrian traffic. Nowadays, the following types of barricades are being used exclusively in BMC as per the convenience of various departments at different sites.

1. Water/s and tillable PVC Metro barricades.
2. RW7.45 (G.I. sheets of 22 gauge fixed on 3 inch dia. Wooden bullies buried in existing road sufficiently)
3. RW7.36 (G.I. sheets of 22 gauge fixed on MS Angle post buried in half the depth in drums of 20 litres capacity in 1:3:6 concrete).
4. Structural steel barricade for major trenches having depth more than 2.00 meters.

Thus, from the above, it can be seen that there is no uniformity in provision of barricades as they are of different size and shape. Further it is also observed that the continuity is not maintained in providing the barricading keeping gaps in between thus endangering the safety of vehicular as well as pedestrian traffic. Also the barricades are not being cleaned, thus further adding to shabbiness. Further Mumbai being the financial capital of India, people from all over the world visit the city daily and to maintain good image of city the following decisions are taken.

- A. Only two type of barricades having department wise colour coding are proposed to be used depending upon the nature of work i.e. Minor and Major.

- i. **Minor works:** Barricading made out of 1.5 mm thick MS plate fixed on M.S. angle post, V frame of 65 mm X 65 mm X 6 mm having height of 1.5m supported on as shown in Annex-1.
 - ii. **Major works:** Structural steel barricade made out of 1.50 mm thick M. S. Plate ISMB 250,1 SLC 250 X 50 mm and ISA 50mmX50mmX6mm having of size 2.5mX2m as shown in Annex-11.
- B. The department wise colour coding for the barricading shall be as under: -
- i. H.E. & W.S.P. department - **Blue**
 - ii. Roads, Traffic, Bridges and Coastal Roads department- **Yellow**
 - iii. S.P. & S.O department- **Green**
 - iv. S.W.D., Building Maintenance department & forward works -**Red**
- C. The basic principle behind installing secured and continuous barricading is to ensure the safety of vehicular as well as pedestrian traffic and residents in the nearby vicinity of the project. Due to non-installation of appropriate barricades on sites if any mishap occurs leading to injury or loss of life, then the contractor and contractor's Engineer in-charge will be liable for the consequent action.
- D. During the course of execution of project, if it is noticed that the contractor has not provided barricading then a penalty of Rs.1000/- per meter per day will be imposed upon the contractor and will be deducted from the due Bill. This penalty shall be a part of penalty as per tender condition.
- E. Details of the work shall be prominently displayed on the central panel of the barricades along-with the Social Slogans as given in Annexure-III and the Cycle of the same shall be maintained.
- F. The contractor shall provide and install the barricading along with the slogans printed as per the Annexure III, at his own cost and no payment will be made for this; however, the contractor shall quote the bid accordingly by considering the cost of barricading.

The condition shall be included in the tender as given below. "Barricading shall be provided free of cost as per Circular vide U/No.MGC/F/6342 dated 5.5.2018 and as per Annexure I, II and III of Standard drawings and specifications with slogans and department wise colour codes." The copy of circular will be attached to the tender as a part of tender document. This circular will be applicable for the new tenders proposed to be invited from 01.05.2018 and also the corrigendum shall be attached to tenders which are uploaded. However, for the projects wherein the tenders are already invited, the barricading shall be provided strictly as per tender condition. All the details (Annexure I, II & III of Standard drawings and specifications with slogans and department wise colour codes, sketches and department wise colour coding) are uploaded on BMC portal.

This circular shall come in force with immediate effect.

sd/- 20.4.2018
{Shri. V. P. Chithore)
Dir.(ES&P)

sd/-20.4.2018
(Shri. R. B. Bambale)
D.M.C.(S.E.)

sd/- 21.4.2018
{Shri. Vijay Singhal)
A.M.C.(E.S.)

sd/- 21.4.2018
(Dr. Shri. Sanjay Mukherjee)
A.M.C.(P.)

sd/-16.5.2018
(Shri. P. R. Kadam)
D.M.C.(S.E.)

sd/-16.05.2018
(Ajoy Mehta)
M.C.

ANNEXURE I

A. Minor Work

Providing, fabricating and installing the barricading made out of 1.5m high M.S. Angle post of 65mm x 65mm x 6mm with 1.5 mm thick M.S. Sheet of size 1.55m x 1.2m welded to the M.S. angle post/frames and fixed to 75mm x 75mm x 6mm angle base as shown in sketch for minor works, displaying of the social slogan as per the Annex-III, daily cleaning of the same to get better appearance and interlocking arrangement to ensure continuity in provision and to avoid gap in between etc complete and as directed by Engineer in-Charge.

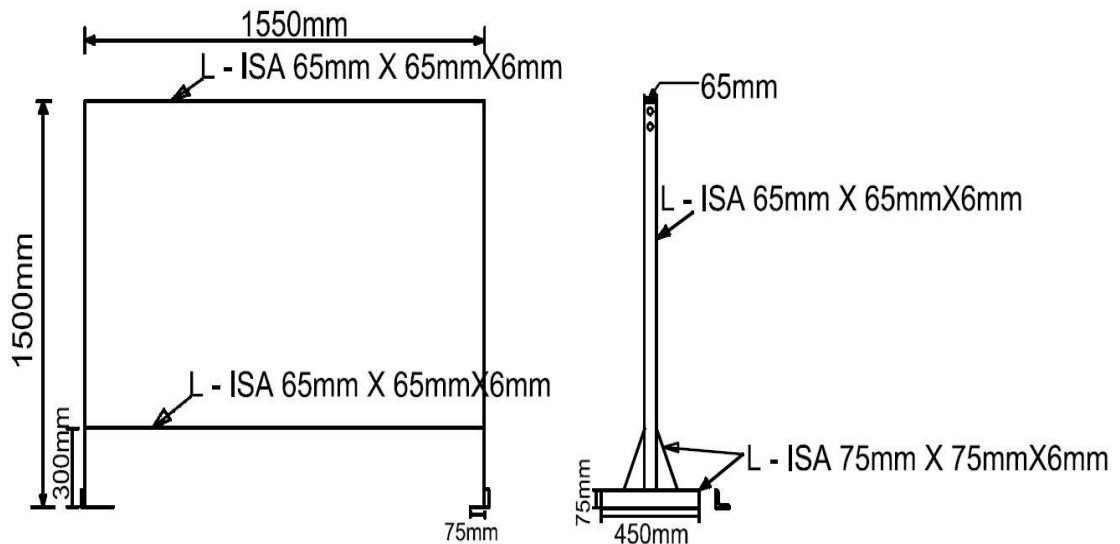

ANNEXURE II

B. Major Works:

Providing, fabricating and installing the structural steel barricading made out of 1.5mm thick M.S. plate of size 2500mm x 2000mm, ISMC 250 x 50 Channels, M.S. Angles ISA 50 x 50 x 6mm and ISMB 250 as per IS 1161 – 1 RHS/SHS rolled angle plates of TATA Steel, Lloyd Steel, SAIL, ESSAR steel approved in straight profile of all sizes, shapes and for all works including stiffeners, bolts and nuts, fillet/butt welding, splicing, machine grinding, of all member joints wherever required to give neat appearance and daily cleaning the barricading along with displaying of the Depth wise slogans as given in Annexure – III etc with interlocking arrangement to avoid gap in between and as directed by Engineer-in-Charge.

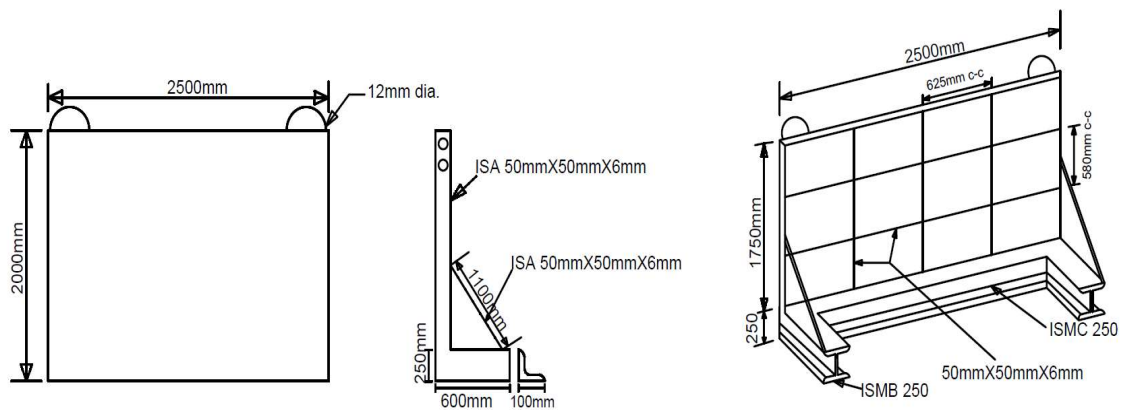

ANNEXURE III

1. HYDRAULLIC ENGINEERS's DEPARTMENT /WATER SUPPLY PROJECTS

- i. Inconvenience Regretted
- ii. Ensuring Mumbai's Water Supply
- iii. Save Water Save Life

2. ROAD, TRAFFIC / BRIDGES DEPARTMENT

- i. Inconvenience Regretted
- ii. Working towards a better tomorrow
- iii. My Mumbai, Green Mumbai

3. SEWERAGE PROJECTS DEPARTMENT / SEWERAGE OPERATIONS DEPARTMENT

- i. Inconvenience Regretted
- ii. Reduce Reuse Recycle
- iii. Clean Mumbai, Healthy Mumbai

4. STORM WATER DRAIN DEPARTMENT / WARD WORKS

- i. Inconvenience Regretted
- ii. Working towards a better tomorrow
- iii. Swatch Bharat

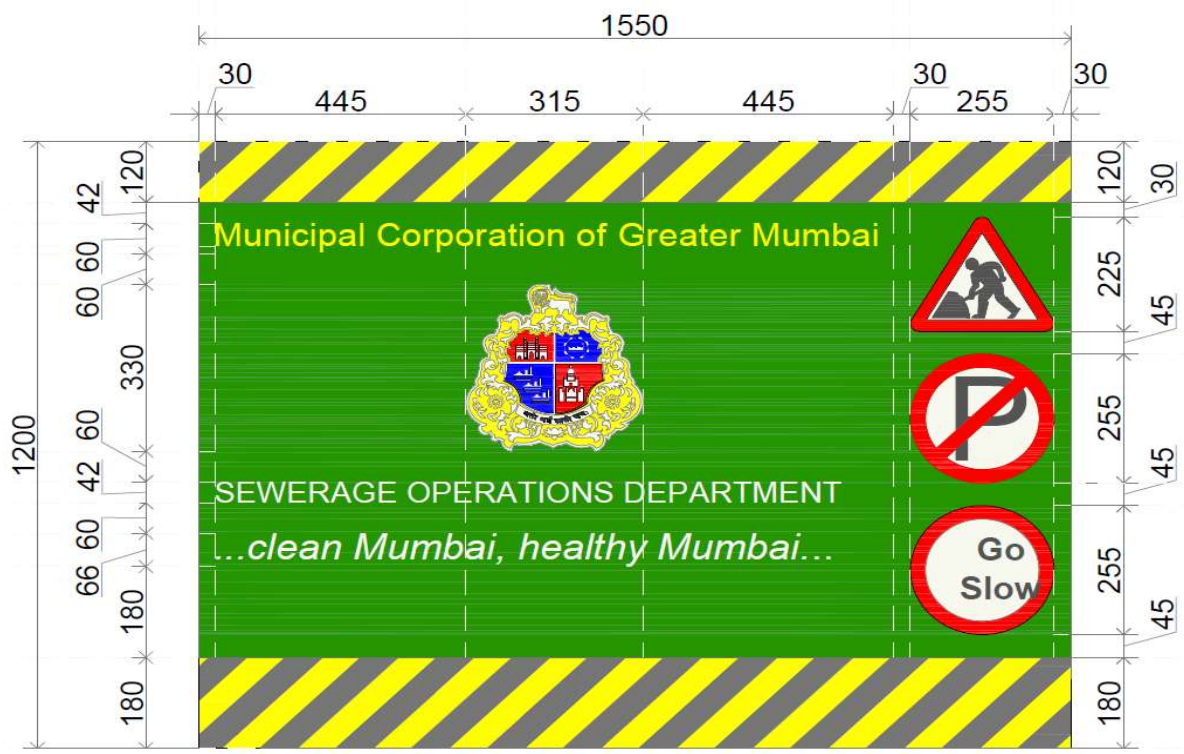

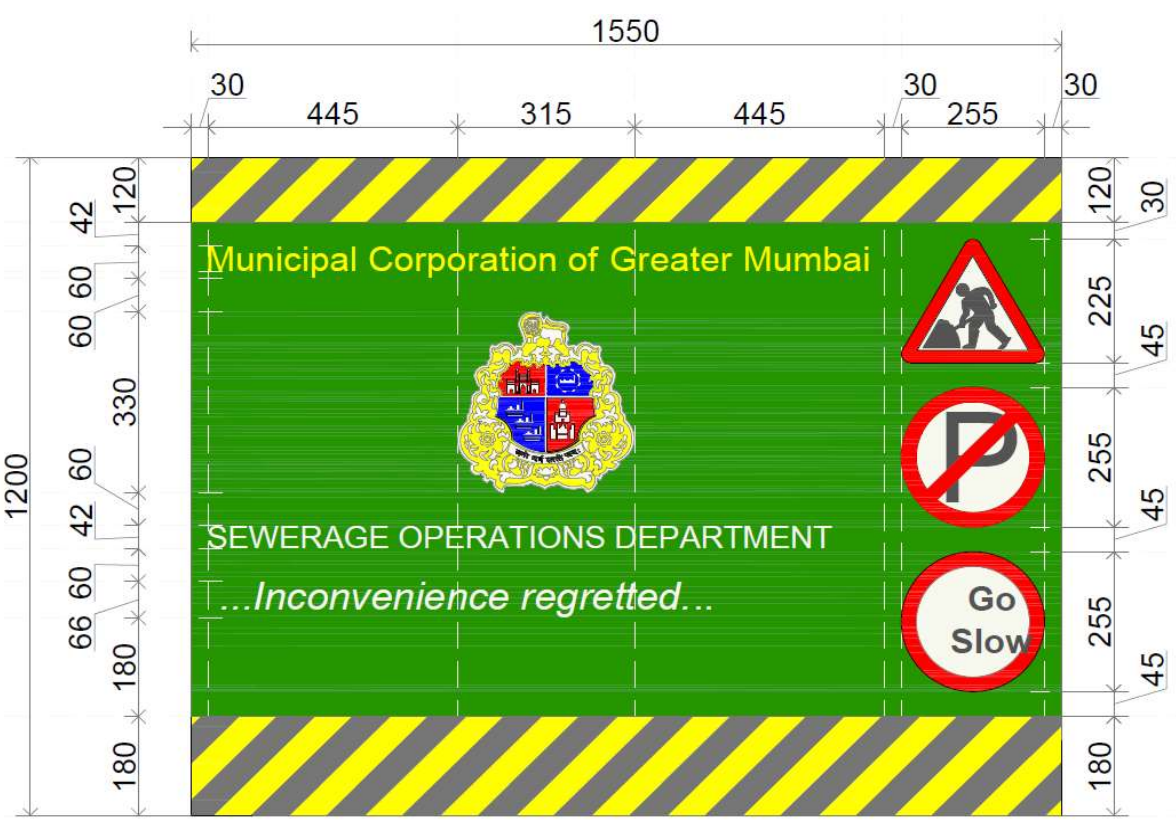

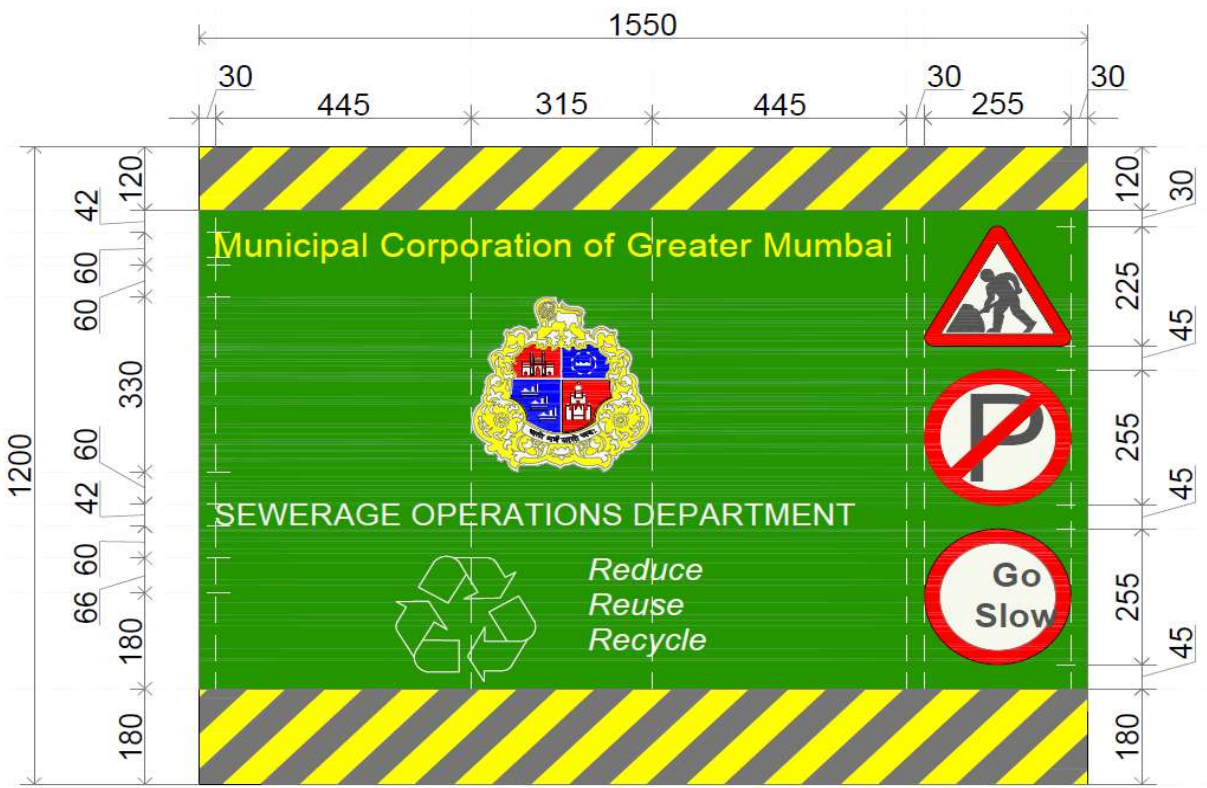

Annexure - K

बृहन्मुंबई महानगरपालिका
विधी खाते

परिपत्रक क्र. २६२०६ दि. ३१.०८.२०२३

विषय - कंत्राट करार करण्यासाठी वसूल करावयाचे विधी आकार (Legal charges) व लेखनसाहित्य आकार (Stationery charges)

- संदर्भ - १. परिपत्रक क्र. १०५३९ दि. २८.०३.२०२३
२. एमजीसी/एफ/५३४ दि. २८.०८.२०२३

महानगरपालिकेच्या विविध खात्यांमार्फत नागविण्यात येणा-या निविदांसंदर्भात लेखी करार करताना यक्षकाराकडून एकत्रितरित्या आकारावयाच्या विधी आकार व लेखनसाहित्य आकाराची उपरोक्त संदर्भित क्र. १ वरील परिपत्रकानुसार दि. ०१.०४.२०२३ पासून आकारणी करण्यात आलेली आहे.

तथापि महानगरपालिका आयुक्त यांच्या संदर्भ क्र. २ च्या मंजूरीनुसार कंत्राट करार करण्यासाठी वसूल करावयाचे विधी आकार (Legal charges) व लेखनसाहित्य आकार (Stationery charges) यामध्ये सुधारणा करण्यात आली असून खालील तक्त्यामध्ये दर्शवित्याप्रमाणे दि.०१.०९.२०२३ पासून सुधारीत विधी व लेखनसाहित्य (एकत्रितरित्या) आकार विहित करण्यात आलेले आहेत.

अनु. क्र	कंत्राट किंमत	एकत्रितरित्या आकारावयाचे सुधारीत विधी व लेखन साहित्य आकार दि. ०१.०९.२०२३ पासून दि. ३१.०३.२०२४ पर्यंत
१	रु. ५०,०००/-	निरक
२	रु. ५०,००१ ते रु. १,००,००,०००	कंत्राट किमतीच्या ०.१०% दराने (अर्बी येणारी रक्कम पुढील शंभराच्या पटीत परावर्तित करणे पासपेक्ष) अधिक १८% दराने वस्तु व सेवाकर (किमान रु. १०००/- अधिक वस्तु व सेवाकर आणि कमाल रु. १००००/- अधिक वस्तु व सेवाकर)
३	रु. १,००,००,००१ ते रु. १०,००,००,०००/-	रु. १,००,००,०००/- पर्यंतच्या कंत्राट किमतीसाठी रु.१०,०००/- अधिक रु. १,००,००,०००/- पेक्षा जास्त रक्कमेवर ०.०५% दराने (अर्बी येणारी रक्कम पुढील शंभराच्या पटीत परावर्तित करणे पासपेक्ष) अधिक १८% दराने वस्तु व सेवाकर

4	रु. 10,00,00,001 ते पुढील कंत्राट किमतीसाठी	रु. 10,00,00,000/- पर्यंतच्या कंत्राट किमतीसाठी रु.55,000/- अधिक रु. 10,00,00,000/- पेक्षा जास्त रकमेवर 0.01% दराने (अशी येवारी रक्कम पुढील शंभरांच्या पटीत परावर्तित करणे यासाठी) अधिक 18% दराने वस्तु व सेवाकर
---	---	---

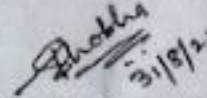

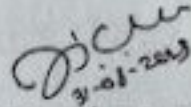
31/8/23
(शोभा अजितकुमार)
उप कायदा अधिकारी
(हस्तांतरण -2)
विधि खाते

31-08-2023
(संदिप मो. पाटील)
संयुक्त कायदा अधिकारी (प्र.)
(शहर विवाणी न्यायालय)
विधि खाते

31/8/2023
(सुनिल सोनवणे)
कायदा अधिकारी
विधि खाते

परिपत्रक क्र. दि. 31.08.2023

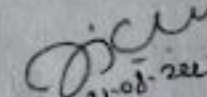
प्रत यांना माहितीकरीता व पुढील आवश्यक त्या कार्यवाहीकरीता अग्रेषित.

31-08-2023
(संदिप मो. पाटील)
उप कायदा अधिकारी (आस्थापना)
विधि खाते

Annexure – L

BRIHANMUMBAI MAHANAGARPALIKA

CIRCULAR
2020-21

No.CA(F)/Project/ 32 of 26.10.2020

Sub : Bid Security or EMD

Ref : No.MDD/7878 of 27.09.2016

The MCGM's tender conditions have been amended and Standard Bid Document has been circulated vide No.MDD/7878 of 27.09.2016.

The condition of refund of Bid Security or EMD incorporated in SBD, is as follows :-

- (i) The Bid Security of the successful bidder will be discharged when the bidder has signed the agreement and furnished the required Security Deposits.
- (ii) The Bid Security/EMD of L-3 and bidders shall be refunded immediately after opening of financial bid but **the EMD/ASD submitted by the L-2 bidder will be returned after obtaining Standing Committee Resolution.**

In recent past, due to COVID-19 pandemic, various benefits and relief are given to contractor for ease of doing business and to maintain their cash flow. Further, the Statutory Committee meetings are not held in this pandemic situation. Hence, the condition of refund of Bid Security/EMD and ASD is reviewed and revised condition for all invited tenders wherein Statutory Committee's sanction has not been accorded and forthcoming e-tenders –

- (a) The Bid Security/EMD of the successful bidder will be discharged when the bidder has signed the agreement and furnished the required Security Deposits.
- (b) The Bid Security/EMD and ASD of L-2 and other higher bidders (L-3, L-4, etc.) shall be refunded immediately after opening of financial bid.

(c) In case, the successful bidder becomes non-responsive or successful bidder withdraws the bid or is unwilling to extend the bid validity period, in such circumstances, if L-2 bidder is agreeable to extend the bid validity period and ready to deposit the requisite amount of bid security/EMD and ASD to the department within the stipulated time period i.e. 15 days, the department will process further as per normal procedure.

The above revised directives shall come into effect immediately on issuance of this circular.

All Chief Engineers/Head of Departments/Deans shall note the above directives and follow them scrupulously.

Sd/-13.10.2020
C.A.(W.S.S.D.)

Sd/-13.10.2020
C.A.(Finance)i.c

Sd/-13.10.2020
D.M.C.(Infra)

Sd/-13.10.2020
D.M.C.(E)

Sd/-13.10.2020
Dir.(ES&P)

Sd/-16.10.2020
A.M.C.(P)

Sd/-23.10.2020
Municipal Commissioner

Annexure – M

बृहन्मुंबई महानगरपालिका

परिपत्रक

२०२०-२१

ज.प्रले(वित्त)/४२ दिनांक ०९.०२.२०२१

विषय:- बृहन्मुंबई महानगरपालिकेत कंत्राटदारांमार्फत पार पाडण्याच्या कामाच्या मसुदा निविदेमध्ये अतिरिक्त सुरक्षा अनामत रक्कमेबाबतची सुधारित अट समाविष्ट करण्याबाबत.

संदर्भ:- एमडीडी/७८७८ दिनांक २७.०९.२०१६.

बृहन्मुंबई महानगरपालिकेत कंत्राटदारांमार्फत पार पाडण्यात येणाऱ्या कामाकरिताच्या मसुदा-निविदेत समाविष्ट करावयाच्या अतिरिक्त सुरक्षा अनामत रक्कमेबाबतच्या अटीबाबतचे निर्देश संदर्भित परिपत्रकांन्वये निर्गमित करण्यात आले आहेत. त्यामध्ये खालीलप्रमाणे सुधारणा करण्यात येत आहे.

विद्यमान पध्दत:-

ई-निविदा सुवनेस प्रतिसाद करून ज्या ज्या कंत्राटदारांनी वजा -१२% पेक्षा कमी दराने टक्केवारी उद्धृत केली आहे, अशा सर्व कंत्राटदारांना वजा १२% पेक्षा जास्त नमूद केलेल्या प्रत्येक टक्क्याला १% याप्रमाणे कोणतीही भरपाय न देवता ऑनलाईन निविदा सादर करताना अतिरिक्त सुरक्षा अनामत रक्कम ऑनलाईन स्विकारली जाते.

सुधारित पध्दत:-

१. कंत्राटदारांने वजा -१२% पेक्षा कमी दराने टक्केवारी उद्धृत केली असल्यास वजा १२% पेक्षा जास्त असलेल्या प्रत्येक टक्क्याला १% याप्रमाणे ऑनलाईन निविदा सादर करताना अतिरिक्त सुरक्षा अनामत रक्कमेचा ऑनलाईन भरणा करणे आवश्यक नसेल.

२. कंत्राट रकमेनुसार सक्षम प्राधिकार्यांची मंजूरी प्राप्त झाल्यानंतर प्रथम लघुत्तम असलेल्या निविदाकाराने कार्यस्थिकृती पत्रात नमूद केल्यानुसार कार्यालयीन कामकाजाच्या १५ दिवसात विद्यमान पध्दतीनुसार अतिरिक्त सुरक्षा अनामत रक्कम डिमांड ड्राफ्ट स्वरूपात महानगरपालिकेचा नागरी सुविधा केंद्रात जमा करणे व त्या पावतीची प्रत खातेप्रमुखाकडे सादर करणे आवश्यक असेल.

३. जर प्रथम लघुत्तम निविदाकाराने कार्यस्थिकृती पत्रात नमूद केल्यानुसार कार्यालयीन कामकाजाच्या १५ दिवसांमध्ये अतिरिक्त सुरक्षा अनामत रक्कम जमा केली नाही तर सदर कंपनीने भरणा केलेली संपूर्ण इसारा अनामत रक्कम (EMD) जप्त केली जाईल तसेच कंपनीला दोन वर्षासाठी डीबार (Debar) करण्यात येईल, त्याचप्रमाणे त्या कंपनीचे संचालक/

LoA)

(After giving)

पार्टनर इतर कंपनीमध्ये संचालक/ पार्टनर म्हणून कार्यरत असतील तर ती कंपनी सुद्धा दोन वर्षांकरिता डीबार (Debar) करण्याची कार्यवाही करण्यात येईल.

यापुढील कामांकरिताच्या मसुदानिघिदेत परिपत्रकात नमूद केल्याप्रमाणे अतिरिक्त सुरक्षा अनामत रकमेबाबतची अट अंतर्भूत करण्यात यावी.

उपरोक्त सूचनांचे काटेकोरपणे अंमलबजावणी करण्याबाबत सर्व खाते प्रमुख/ सहाय्यक आयुक्त/ रुग्णालय अधिष्ठाता/ वैद्यकीय अधीक्षक/ उप प्रमुख लेखापाल/ लेखा अधिकारी यांनी दक्षता घ्यावी.

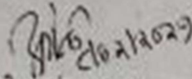
(श्री. अनंत कदम)

उपायुक्त - (पायाभूत सुविधा)

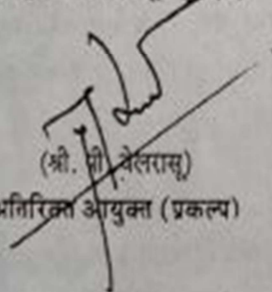
(श्री. सी. वेलराव)

अतिरिक्त आयुक्त (प्रकल्प)

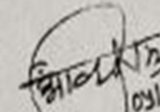
(रा. क. अचर्या)

प्रमुख लेखापाल (वित्त) प्र.

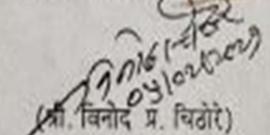
(श्री. विनोद प्र. चिटोरे)

संचालक (अ.से.व.प्र)

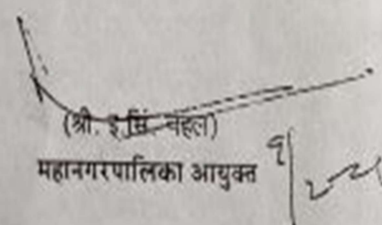
(श्री. इ.मि. व्होला)

महानगरपालिका आयुक्त

Annexure – N

बृहन्मुंबई महानगरपालिका
परिपत्रक

प्र.ले./वित्त/प्रकल्प/२८ दि. २८/०३/२०२३

विषय: एकसामायिक दरसूची २०२३ अंतर्भूत करून महानगरपालिकेद्वारे हाती घेण्यात येणारी विविध कामे तसेच प्राप्त करण्यात येणा-या वस्तु व सेवा इत्यादीबाबतच्या ई-निविदा/निविदा/दरपत्रक यामध्ये वस्तु व सेवा कराच्या अनुषंगाने अंतर्भूत करावयाच्या अटीबाबत.

संदर्भ: १) प्र.ले./वित्त/प्रकल्प/२५ दि.१२.०७.२०२२

२) संचालक/अ.से.व प्र./२९१/एमसी दि.३१.०१.२०२३

बृहन्मुंबई महानगरपालिकेद्वारे हाती घेण्यात येणारी विविध कामे तसेच प्राप्त करण्यात येणा-या वस्तु व सेवा इत्यादीबाबतच्या ई-निविदा/निविदा/दरपत्रक यामध्ये वस्तु व सेवा कराच्या अनुषंगाने अंतर्भूत करावयाच्या अटीबाबत संदर्भित क्र. १ वरील परिपत्रकान्वये सूचना प्रसूत केल्या आहेत.

महानगरपालिका आयुक्त यांच्या क्र. एमजीसी/एफ/८७७१ दि. ३०.०१.२०२३ अन्वये एकसमान दरसूची २०२३ प्रसारीत करण्यात आली आहे. सदर एकसामायिक दरसूची २०२३ हि वस्तु व सेवाकर वगळून तयार करण्यात आली आहे. सदर अद्ययावत एकसामायिक दरसूची २०२३ नुसार अंदाजपत्रक तयार करून मागविण्यात आलेल्या/येणा-या ई-निविदा/निविदा/दरपत्रक यामध्ये वस्तु व सेवाकराच्या अनुषंगाने महानगरपालिकेद्वारे हाती घेण्यात येणारी विविध कामे तसेच प्राप्त करण्यात येणा-या वस्तु

व सेवा इत्यादीबाबतच्या ई-निविदा/निविदा/दरपत्रक यामध्ये संदर्भित क्र.१ अन्वये दिलेल्या अटीमध्ये पुढीलप्रमाणे बदल करण्यात येत आहे.

विद्यमान अट	सुधारित अट
<p>“GST and other state levies/cess which are not subsumed under GST will be applicable. The tenderer shall quote inclusive of all taxes applicable at the time of bid submission. It is clearly understood that BMC will not bear any additional liability towards payment of any Taxes & Duties.</p> <p>Wherever the services to be provided by the Tenderers, falls under Reverse Charge Mechanism, the Price quoted shall be exclusive of GST, but inclusive of Taxes/Duties/Cess other than GST, if any.</p> <p>Rates accepted by BMC shall hold good till completion of work and no additional individual claim shall be admissible on account of fluctuations in market rates; increase in taxes/any other levies / tolls etc. except that payment/recovery for overall market situation shall be made as per Price variation and if there is any subsequent change (after submission of bid) in rate of GST applicable on the work/services to be executed as per tender, i.e. any increase will be reimbursed by BMC whereas any reduction in the rate of GST shall be passed on to BMC as per the provisions of the GST Act.</p>	<p>The tenderer shall quote inclusive of all taxes other than GST (Excluding GST), Levies, Duties, Cess etc as applicable at the time of bid submission. GST as applicable shall be paid separately on submission of bills/invoice.</p> <p>Input Tax Credit of GST as available with the bidder will not be claim separately by BMC. However, while quoting the rates benefit of Input Tax Credit or Exemptions shall be passed on to the BMC by way of equivalent reduction in quoted price.</p>

उपरोक्त सुधारीत अट अद्ययावत एकसामायिक दरसूची २०२३ नुसार अंदाजपत्रक तयार करून मागविण्यात आलेल्या/ येणा-या ई-निविदा/निविदा/दरपत्रक या कामांकरिता लागू असेल.

अतएव, सध्या ज्या ई-निविदा/निविदा/दरपत्रक एकसामायिक दरसूची २०२३ अंतर्भूत करून मागविलेल्या आहेत अशा निविदांमध्ये नियत दिनांकापूर्वी शुद्धीपत्रकाद्वारे उपरोक्त सुधारीत अट समाविष्ट करण्याबाबत तसेच बापुढे एकसामायिक दरसूची २०२३ अंतर्भूत करून मागविण्यात येणा-या ई-निविदा/निविदा/दरपत्रक यांमध्ये उपरोक्त सुधारीत अट समाविष्ट करण्याबाबत संबंधित खातेप्रमुख यांनी दक्षता घ्यावी.

सर्व खातेप्रमुख, रूग्णालयांचे अधिष्ठाता, सहायक आयुक्त, यांनी उपरोक्त सुचनांचे काटेकोरपणे अनुपालन करावे.

सही/- २८/०३/२०२३

(पांडुरंग गोसावी)

प्रमुख लेखापाल (पा.पु.म.नि.)

सही/- २८/०३/२०२३

(प्रदिप पडवळ)

प्रमुख लेखापाल (वित्त) प्र.

सही/- २८/०३/२०२३

(रामदास आक्काड)

उप आयुक्त (वित्त)

सही/- २८/०३/२०२३

(पी. वेलरासू)

अतिरिक्त आयुक्त (प्रकल्प)

Annexure – O

MUNICIPAL CORPORATION OF GREATER MUMBAI

CIRCULAR

No.CA (F)/Project/31 Dt. 26/10/2020.

Subject: - Revised Policy for Governing Extra-excess-saving

Ref:- 1. Circular No.CA/FRD/I/57 dt.13.03.2013.
2. Circular No. Dir/E.S.&P./324 dt.15.07.2015.

At present the extra/excess/saving proposals are dealt as per Decision Rules framed under circular No.CA/FRD/I/57 of 13.03.2013 &Dir/E.S.&P./324 dt.15.07.2015.

Hon'ble M.C. has directed to review the existing Decision Rules and amend it suitably. Accordingly, in view to exercising effective control over the extra/excess and speedy process of such proposal during execution of the work, the powers of approval of extra/excess /saving and Fair items are reviewed and delegated according to the attached modified statement-"A". Except this, other conditions of Circular No. DIR./E.S.&P./324 dt.15.07.2015 shall remain unchanged and will be applicable as it is.

The "Decision Rules" framed and circulated apropos circular No.CA/FRD/I/57 of 13.03.2013 and Dir/ES&P/324 of 15.07.2015 shall remain applicable for those extra/excess works which were executed before issuance of these amended rules/directives by obtaining prior administrative approval of competent authority, as the case may be.

The revised policy for governing Extra/Excess and Fair items will come into effect immediately from the issuance of this circular.

All Chief Engineers/ Head of Departments/Deans shall note the above directives and follow them scrupulously.

Sd/- 13.10.2020

C. A. (WSSD)

Sd/- 13.10.2020

C. A. (Finance)Lc.

Sd/- 13.10.2020

D.M.C. (Infra)

Sd/- 13.10.2020

D.M.C.(E.)

Sd/- 14.10.2020

D.M.C.(S.E.)

Sd/- 13.10.2020

Dir.(E.S.&P.)

Sd/- 16.10.2020

A.M.C. (Project)

Sd/- 23.10.2020

Municipal Commissioner

Statement - A

(i) Extra/Excess/Saving

Permissible limit of Extra/Excess/Saving and Approving authority			
Nature of work	DMC(Infra)/ DMC(E)/ DMC(SE)/ Dir(ES&P)/ Jt.M.C.	Concerned A.M.C.	Municipal Commissioner
General Work/ Underground works/ Unforeseen works	(i) <u>Cumulative</u> amount of Extra/Excess/Saving in any <u>individual item</u> Upto Rs.25 Lakh And (ii) Total <u>Cumulative</u> amount of Extra/Excess/Saving <u>on all items</u> upto 5% of the total contract cost, but not exceeding Rs.1 crore	(i) <u>Cumulative</u> amount of Extra/Excess/Saving in any <u>individual item</u> Upto Rs.1 crore And (ii) Total <u>Cumulative</u> amount of Extra/Excess/Saving <u>on all items</u> upto 15 % of the total contract cost, but not exceeding Rs.10 crore	(i) <u>Cumulative</u> amount of Extra/Excess/Saving in any <u>individual item</u> above Rs.1Crore And / OR (ii) Total <u>Cumulative</u> amount of Extra/Excess/Saving <u>on all items</u> above 15% of the total contract cost. And / OR <u>Cumulative</u> amount of Extra/Excess/Saving <u>on all items</u> exceeding Rs.10 Crores.
<p>Payment Terms: <u>Excess Items</u> shall be paid as per the rates quoted by the tenderer at the time of tender <u>Extra Items</u> shall be paid as per the rate prevailing in "Unified Schedule of Rate" of MCGM at the time of tender at rebate quoted by the contractor or at Par in case of premium quoted by the contractor at the time of tender</p>			

(ii) Fair Item

Nature of work	Permissible limit of Fair Item and Approving authority		
	DMC(Infra)/ DMC(E)/ DMC(SE)/ Dir(ES&P)/ Jt.M.C.	Concerned A.M.C.	Municipal Commissioner
For all nature of work	Total <u>Cumulative</u> amount of Fair <u>on all items</u> upto 2% of the total contract cost, but not exceeds Rs.20 Lakh	Total <u>Cumulative</u> amount of Fair <u>on all items</u> upto 5 % of the total contract cost, but not exceeds Rs.1 crore (Other than the proposals in the purview of DMC/Jt.MC)	Total <u>Cumulative</u> amount of Fair <u>on all items</u> above 5% of the total contract cost. And / OR <u>Cumulative</u> amount of Fair <u>on all items</u> exceeding Rs.1 Crore.

Payment Terms:

Fair Items shall be got approved by the concerned DMC/Dir(ES&P)/Jt.M.C. The engineer in-charge shall work out these fair items at fair and reasonable market rates on the basis of material, labour and operation of construction equipment required to execute the item and allowing 15% to cover profits and overhead charges(i.e. including taxes, duties, etc.) On the same lines of rate analysis prepared for the items that are in "Unified Schedule of Rate" of MCGM.

The rates of Fair Items shall be valid for one year only. Moreover, no escalation will be admissible on the fair items till the completion of such works, in which the fair items are executed.

Fair Items shall be paid at **PAR** in case of premium quoted by the contractor, in newly created FAIR ITEM or item not included in prevailing "Unified Schedule of Rate" of MCGM at the time of tender. OR at rebate quoted by the contractor if it is already added in prevailing "Unified Schedule of Rate" of MCGM at the time of tender.

Sd/- 13.10.2020 Sd/- 13.10.2020 Sd/- 13.10.2020 Sd/- 14.10.2020 Sd/-13.10.2020
 C. A. (WSSD) C. A. (Finance)l.c. D.M.C.(Infra) D.M.C.(E.) Dir.(E.S.&P.)

Annexure – P

MUNICIPAL CORPORATION OF GREATER MUMBAI

No. : MGC/F/8659 Dtd. 07.09.2019.

Sub : Arbitration clause in the Standard General Conditions of Contract for Construction Works, 2016.

In one of the cases of W.S.P. regarding arbitration dispute, a note was submitted by DyLaw Officer (High Court, Suit & PIL) and subsequently the report is submitted by Jt. M.C. (Vig.) vide No. Jt.M.C./Vig./69/MC dtd. 21-8-2019 proposing a process to deal with the arbitration matters as per the Law & Judiciary, Govt. of Maharashtra, policy for institutional arbitration vide it's G.R. dtd. 13-10-2016 and the report submitted by Jt. M.C. (Vig.) is approved by Hon'ble M.C. on 17-8-2019.

There is a provision of arbitration clause in the Standard General Condition of Contract for Construction Works, point no. 13 (e) reads as follows :-

13.e) Arbitration and Jurisdiction:

If the Commissioner shall fail to give notice of the decision as aforesaid within a period of 90 days after being requested as aforesaid, or if the Contractor be dissatisfied with any such decision, then and in any such case the Contractor may within 90 days after receiving notice of such decision or within 90 days after the expirations of the first named period of 90 days (as the case may be) require that the matter or matters in dispute be referred to arbitration as hereinafter provided. All disputes or differences in respect of which the decision (if any) of the Commissioner has not become final and binding as aforesaid shall be finally settled by arbitration as follows:

Arbitration shall be effected by a single arbitrator agreed upon the parties. The arbitration shall be conducted in accordance with the provisions of the Arbitration Act, 1996 or any statutory modifications thereof, and shall be held at such place and time within the limits of Brihan Mumbai as the arbitrator may determine. The decision of the arbitrator shall be final and binding upon the parties hereto and the expense of the arbitration shall be paid as may be determined by the arbitrator. Performance under the Contract shall, if reasonably be possible, continued during the arbitration proceedings and payment due to the Contractor by the Employer shall not be withheld unless they are the subject matter of arbitration proceedings. The said arbitrator shall have full power to open up, review and revise any decision, opinion, direction, certification or valuation of the Commissioner and neither party shall be limited in the proceedings before such arbitrator to the evidence or arguments put before the Commissioner for the purpose of obtaining his said decision.

No decision given by the Commissioner in accordance with the foregoing provisions shall disqualify him from being called as a witness and giving evidence before the arbitrator on any matters whatsoever relevant to the disputes or difference referred to the arbitrator as aforesaid.

All awards shall be in writing and for claims equivalent to 5,00,000 or more such awards shall state reasons for amounts awarded. The expenditure of arbitration shall be paid as may be determined by arbitrator.

In case of any claim, dispute or difference arising in respect of a contract, the cause of action thereof shall be deemed to have arisen in Mumbai and all legal proceedings in respect of any claim, dispute or difference shall be instituted in a competent court in the City of Mumbai only.

As per Hon'ble M.C.'s approval dtd. 17-8-2019, the existing clause is now replaced as follows :

13.e Arbitration and Jurisdiction

If the Commissioner fails to give notice of the decision as aforesaid within a period of 90 days after being requested as aforesaid or if the Contractor is dissatisfied with any such decision, then the Contractor may within 90 days after receiving notice of such decision or within 90 days after the expiration of the first named period of 90 days (as the case may be) require that the matter or matters in dispute be referred to arbitration as hereinafter provided.

i) In case of a contract where the contract price and/ or contract value is less than Rs. 5,00,00,000/- (Rupees Five Crore Only), any dispute arising out of or in connection with this contract, including any question regarding its existence, validity or termination, shall be referred to a mutually agreed arbitral tribunal in accordance with the Arbitration and Conciliation Act, 1996 (amended upto date). The arbitral tribunal shall consist of a sole arbitrator, as mutually agreed upon by the parties and the said dispute shall be finally resolved by the said arbitral tribunal. The decision of the arbitral tribunal shall be in writing (with reasons) and which will be final and binding upon the parties hereto and the expenses of the arbitration shall be paid as may be determined by the arbitral tribunal. The seat of the arbitration shall be Mumbai. The venue of arbitration shall be within the limits of Brihan Mumbai. The language of the Arbitration shall be English.

If the parties fails to appoint mutually agreed arbitral tribunal, within the period of 30 days from the date of application seeking arbitration in the dispute,

the arbitral tribunal shall be appointed by the recognised arbitral institution i.e. Mumbai Centre for International Arbitration (approved by Government of Maharashtra under G.R. no. ARB/Case No. 1/2017/D-19 dtd. 28.02.2017) as per the Arbitration Rules of the Mumbai Centre for International Arbitration then in force ("MCIA Rules").

(ii) In case of contract where the contract price and/ or contract value is Rs.5,00,00,000/- (Rupees Five Crore Only) or more, any dispute arising out of or in connection with such a contract, including any question regarding its existence, validity or termination, shall be directly referred to and finally resolved by the recognized arbitral institution i.e. Mumbai Centre for International Arbitration (approved by Government of Maharashtra under G.R. no. ARB/Case No. 1/2017/D-19 dtd. 28.02.2017) as per the Arbitration Rules of the Mumbai Centre for International Arbitration then in force ("MCIA Rules"). The arbitral tribunal shall consist of a sole arbitrator. The seat of the arbitration shall be Mumbai. The language of the Arbitration shall be English.

In either case, the law governing this arbitration agreement and the contract shall be Indian Law.

All the HoDs are hereby directed to note the revised clause in G.C.C. as mentioned above and ensure that the same is included in the tenders invited from 15-1-2019 onwards. If the tenders are already invited before 15-1-2019 and the Packet 'A' is not opened, then the corrigendum shall be issued so as to see that all the new tenders accepted/invited after 15-9-2019 shall include this revised condition and will become a part of the contract for all such works.

Sd/-22.08.2019
Dir. (E.S. & P.)
P

Sd/-29.08.2019
A.M.C. (P)

Sd/-06.09.2019
M.C.

No. : DIR/ES&P/919/MC dtd. 16.09.2019.

Copy to :

Asstt. Comm. Ward / City Engineer/Ch.Eng.(Roads & Traffic) / Ch.Eng. (Bridges) / H. E. / Ch.Eng. (WSP) / Ch.Eng. (S.P.) / Ch.Eng.(MSDP) / Ch.Eng. (BM) / Ch.Eng.(Vig) / Ch.Eng. (M&E) / Ch.Eng.(D.P.)/Ch.Eng.(SWD) / Ch.Eng.(SWM) / Ch.Eng.(CTIRC)/Ch.Eng. (Coastal Roads) / Dy. Ch.Eng.(HIC) / Dy.Ch.Eng.(SIC), Supdt. of Gardens / CA (F) / CA (WSSD) / CA (CPD)

Forwarded for information and necessary action please.

Annexure – Q

MUNICIPAL CORPORATION OF GREATER MUMBAI

No. : MCGM/F/6565 dtd. 25-9-2018

CIRCULAR

Sub : **Setting up the parameters of litigation history of the bidders.**

As approved by Hon'ble M.C., the clause of litigation history be included as part of SBD as below :

- 1) The bidder shall disclose the litigation history in Packet 'B' under the head "Details of Litigation History".

If there is no Litigation History, the bidder shall specifically mention that there is no Litigation History against him as per the clause of Litigation History. In case there is Litigation History -

Litigation History must cover - Any action of blacklisting, debaring, banning, suspension, deregistration and cheating with MCGM, State Govt., Central Govt. or any authority under State or Central Govt./Govt. organisation initiated against the company, firm, directors, partners or authorized signatory shall be disclosed for last 5 years from the date of submission of bid. Also, bidder must disclose the litigation history for last 5 years from the date of submission of bid about any action like show cause issued, blacklisting, debaring, banning, suspension, deregistration and cheating with MCGM and MCGM is party in the litigation against the company, firm, directors, partners or authorized signatory for carrying out any work for MCGM by any authority of MCGM and the orders passed by the competent authority or by any Court where MCGM is a party. While taking decision on litigation history, the concerned Chief Engineer or D.M.C. or Director, as may be the case, should consider the details submitted by bidder and take decision based on the gravity of the litigation and the adverse effect of the act of company, firm, directors, partners or authorized signatory on the MCGM works which can spoil the quality, output, delivery of any goods or any work execution and within the timeframe.

- 2) The litigation history shall be treated as curable defect and hence, the portion/clause of SBD, (C) Bid Capacity as Pg. 13 & in the chapter of 'Instructions to Applicants' at Pg. 31 of the SBD will be now corrected by deleting the word litigation history and shall be read as below.

C) Bid Capacity :

The bid capacity of the prospective bidders will be calculated as under: Assessed Available Bid Capacity = $(A * N * 2 - B)$

Where,

A = Maximum value of Civil Engineering works executed in any one year (year means Financial year) during the last five years (updated to the price level of the Financial year in which bids are received at a rate of 10% per year) taking into account the completed as well as works in progress.

N = Number of years prescribed for completion of the Project/Works, excluding monsoon period, for which these bids are being invited. (E.g. 7 months = 7/12 year). For every intervening monsoon, 0.33 shall be added to N.

B = Value of existing commitments (only allotted works) on the last date of submission of bids as per bidding document and on-going works to be completed during the period of completion of the Project/Works for which these bids are being invited.

Note: The statement showing the value of existing commitments and on-going works as well as the stipulated period of completion remaining for each of the works listed should be attached along with certificates duly signed by the Engineer-in Charge, not below the rank of an Executive Engineer or equivalent.

Even though the bidders meet the above qualifying criteria, they are subject to be disqualified if they have:

- made misdealing or false representation in the forms, statements and attachments submitted in proof of the qualification requirements; and/or
- Record for poor performance such as abandoning the works, not properly completing the contract, inordinate delays in completion, litigation-history, or financial failures etc."

All the concerned are directed to implement the above directions with immediate effect.

O/c

Director (E.S. & P.)

City Engineer/Ch.Eng.(Roads & Traffic) / Ch.Eng. (Bridges) / J. E. / Ch.Eng. (WSP) / Ch.Eng.(S.P.) / Ch.Eng.(S.O.) / Ch.Eng.(MSDP) / Ch.Eng. (HM) / Ch.Eng.(Vie) / Ch.Eng. (MSE) / Ch.Eng.(D.P.) / Ch.Eng.(SWD) / Ch.Eng. (Coastal Regn) / Ch.Eng.(SWM) / Ch.Eng.(CTIRC) / Ch.Eng.(HIC) / Dy.Ch.Eng.(SIC) / Supr. of Gardens'

Asstt. Comm. Ward / Asstt. Comm.(Markets) / Asstt. Comm. (Estate) / Asstt. Comm.(Planning) / Asstt. Comm.(R.E.) City/W.S./F.S.

No. DIR/ES & P/915/MC dttd. 27-9-2018

C.C. to : DMC(MC) / DMC (Hse) / DMC(GA) / DMC(Vie) / DMC(SE) / DMC(EV) / DMC(CPD) / DMC(SWM) / DMC (Education) / DMC (RE) / DMC(PH) / DMC(Z-D) / DMC(Z-B) / DMC(Z-BH) / DMC(Z-V) / DMC(Z-VV) / DMC(Z-VI) / DMC(Z-VII) / C.A. (P) / C.A. (WSSD) / C.A. (C.P.D.) / Law Officers

Forwarded for information please. O/c

Director (E.S. & P.)

No. No. DIR/ES & P/915/MC dttd. 27-9-2018

C.C. to:

Submitted please. O/c

Director (E.S. & P.)

A.M.C.(G) / A.M.C.(E.S.) / A.M.C.(W.S.) / A.M.C.(P)

Sir/Madam, —

Annexure – R

बृहन्मुंबई महानगरपालिका

परिपत्रक

२०२५-२६

क्र. सीए / एफआरजी / १५ दिनांक २०.०३.२०२६

विषय :- महानगरपालिकेच्या विविध खात्यांमार्फत मागविण्यात येणाऱ्या अनस्टार दरपत्रिका / निविदा / दरपत्रिका / ई-दरपत्रिका / ई-निविदा दस्तऐवजांकरिता आकारण्यात येणाऱ्या निविदा शुल्कात (Tender Fee) वाढ करण्याबाबत.

संदर्भ :- १) क्र. एमजीसी/एफ/४४७९ दि. ०३.१०.२०२४

२) परिपत्रक क्र. सीए/एफआरजी/०९ दि. ०४.१०.२०२४

३) परिपत्रक क्र. सीए/एफआरजी/१७ दि. १७.०३.२०२५

बृहन्मुंबई महानगरपालिकेच्या विविध खात्यांमार्फत मागविण्यात येणाऱ्या अनस्टार दरपत्रिका / निविदा / दरपत्रिका / ई-दरपत्रिका / ई-निविदा दस्तऐवज यांच्या करिता पक्षकारांकडून आकारण्यात येणारे निविदा शुल्क उपरोक्त संदर्भ क्र. ०३ वरील परिपत्रकानुसार दिनांक ०१.०४.२०२५ पासून दिनांक ३१.०३.२०२६ पर्यंत सुधारीत दराने ऑनलाईन पद्धतीने आकारण्याबाबत निर्देश देण्यात आले होते.

दिनांक ०१.०४.२०२६ पासून मागविण्यात येणाऱ्या अनस्टार दरपत्रिका / निविदा / दरपत्रिका / ई-दरपत्रिका / ई-निविदा दस्तऐवजांच्या किमतीच्या दरांमध्ये सन २०२५-२६ या वर्षामध्ये १०% वाढ करण्यात येत आहे त्यानुसार लागू करावयाचे निविदा शुल्काचे सुधारीत दर खालीलप्रमाणे आहेत :-

अनु क्र.	स्वारस्याची अभिव्यक्ती	अनस्टार दरपत्रिका/निविदा/दरपत्रिका/ ई-दरपत्रिका/ ई-निविदा दस्तऐवजांचे विद्यमान निविदा शुल्क (दि. ०१.०४.२०२५ पासून दि. ३१.०३.२०२६ पर्यंत)	दि. ०१.०४.२०२६ पासून दि. ३१.०३.२०२७ पर्यंत मागविण्यात येणाऱ्या अनस्टार दरपत्रिका/निविदा/दरपत्रिका/ ई-दरपत्रिका/ ई-निविदा दस्तऐवजांचे सर्व देकारदारांकडून वसूल करावयाचे निविदा शुल्क
०१	रु. ०३ लाखापर्यंत	रु. ३६३/- + १८% वस्तू व सेवाकर	रु. ४००/- + १८% वस्तू व सेवाकर
०२	रु. ३,००,००१/- ते रु. ५,००,०००/-	रु. ७२६/- + १८% वस्तू व सेवाकर	रु. ८००/- + १८% वस्तू व सेवाकर

①

J-78695
(1-)

०३	रु. ५,००,००१/- ते रु. १०,००,०००/-	रु. १,४५२/- + १८% वस्तु व सेवाकर	रु. १,६००- + १८% वस्तु व सेवाकर
०४	रु. १०,००,००१/- ते रु. २५,००,०००/-	रु. ३,६३०/- + १८% वस्तु व सेवाकर	रु. ३,९९३/- + १८% वस्तु व सेवाकर
०५	रु. २५,००,००१/- ते रु. ५०,००,०००/-	रु. ७२६०/- + १८% वस्तु व सेवाकर	रु. ७,९८६/- + १८% वस्तु व सेवाकर
०६	रु. ५०,००,००१/- ते रु. १,००,००,०००/-	रु. १४,५२०/- + १८% वस्तु व सेवाकर	रु. १५,९७२/- + १८% वस्तु व सेवाकर
०७	रु. १,००,००,००१/- ते रु. २५,००,००,०००/-	रु. १८,१५०/- + १८% वस्तु व सेवाकर	रु. २१,९६५/- + १८% वस्तु व सेवाकर
०८	रु. २५,००,००,००१/- पेक्षा जास्त	रु. ३०,२५०/- + १८% वस्तु व सेवाकर	रु. ३३,२७५/- + १८% वस्तु व सेवाकर

अनस्टार दरपत्रिका / निविदा / दरपत्रिका / ई-दरपत्रिका / ई-निविदा दस्तऐवजांच्या किमतीचे सुधारीत निविदा शुल्क दिनांक ०१.०४.२०२६ पासून दिनांक ३१.०३.२०२७ पर्यंत अमलात येतील. संदर्भ क्र. २ च्या परिपत्रकातील अन्य निर्देशांमध्ये कोणतेही बदल करण्यात आलेले नाहीत.

हरी सर्व खाते प्रमुख/सहाय्यक आयुक्त / रुग्णालय प्रमुख / अधिष्ठाता यांनी त्यांच्या अखत्यारीतील संबंधित कर्मचारी वृंदांना उपरोक्त सुचनेची काटेकोरपणे अंमलबजावणी करण्याचे तसेच दिनांक ०१.०४.२०२६ पासून मागविण्यात येणाऱ्या अनस्टार दरपत्रिका / निविदा / दरपत्रिका / ई-दरपत्रिका / ई-निविदा दस्तऐवजांकरीता या परिपत्रकातील सुधारीत दरांनुसार निविदा शुल्क आकारण्याचे निर्देश द्यावेत.

सही- ०५.०२.२०२६
श्रीम. वेशाली देसाई
प्रमुख लेखापाल (वित्त) प्र.

परिपत्रक
२०२५-२६
क्र.सीए / एफआरजी /१५ दिनांक २०.०३.२०२६

प्रत(जादाप्रतीसह) यांना माहितीकरिता व पुढील
आवश्यक त्या कार्यवाहीकरिता अग्रेषित.

३-१४

(2)

३३/०३/२०२६
३०.०३.२०२६
प्रमुख लेखापाल (वित्त) यांजकरिता

MS/27 CA BMRP-78695-2026-27 2200 COPIES

Annexure – S

बृहन्मुंबई महानगरपालिका

परिपत्रक
२०२४-२०२५

क्र. सीए/एफआरजी/०९ दिनांक ०४.१०.२०२४

विषय :- महानगरपालिकेच्या विविध खात्यांमार्फत मागविण्यात येणा-या अनस्टार दरपत्रिका/निविदा/दरपत्रिका/ ई-दरपत्रिका/ई-निविदा दस्तऐवजांकरिता छाननी शुल्क(Scrunity Fee) न आकारता निविदा शुल्क (Tender Fee) ऑनलाईन पद्धतीने स्वीकारण्याबाबत.

- संदर्भ :- १) परिपत्रक क्र.सीए/एफआरजी/०३ दि. ११.०५.२०२३
२) परिपत्रक क्र.सीए/एफआरजी/०४ दि.२४.०५.२०२३
३) परिपत्रक क्र.सीए/एफआरजी/१० दि. १९.१०.२०२३
४) परिपत्रक क्र.सीए/एफआरजी/१८ दि.२७.०२.२०२४

बृहन्मुंबई महानगरपालिकेच्या विविध खात्यांमार्फत मागविण्यात येणाऱ्या अनस्टार दरपत्रिका/निविदा/दरपत्रिका/ ई-दरपत्रिका/ई-निविदा दस्तऐवजांकरिता पक्षकारांकडून आकारण्यात येणारे छाननी शुल्क उपरोक्त संदर्भ क्र. ०४ वरील परिपत्रकानुसार दिनांक ०१.०४.२०२४ पासून दिनांक ३१.०३.२०२५ पर्यंत सुधारीत दराने आकारण्याबाबतचे निर्देश देण्यात आले होते.

उपरोक्त संदर्भित क्र ३ चे परिपत्रक क्र.सीए/एफआरजी/१० दिनांक १९.१०.२०२३ च्या निदेशांत बदल करून सर्व अनस्टार दरपत्रिका/निविदा/दरपत्रिका/ ई-दरपत्रिका/ ई-निविदा दस्तऐवजांकरिता छाननी शुल्क (Scrunity Fee) न आकारता सर्व देकारदारांकडून खालील तक्त्यात दर्शविल्यानुसार महाराष्ट्र शासनाच्या महाटॅंडर पोर्टलद्वारे निविदा शुल्क (Tender Fee) अनुज्ञेय वस्तू व सेवाकरासहित ऑनलाईन पद्धतीने आकारण्याचे सुधारित निर्देश देण्यात येत आहेत.

अनु क्र.	स्वारस्याची अभिव्यक्ती प्रस्ताव/ मालाचा पुरवठा/ सल्लागार सेवासह स्थापत्य कामे आणि सेवा इत्यादी विषयक कार्यालयीन अंदाजे रक्कम	दि. ०१.१०.२०२४ पासून दि. ३१.०३.२०२५ पर्यंत मागविण्यात येणाऱ्या अनस्टार दरपत्रिका/निविदा/दरपत्रिका/ ई-दरपत्रिका/ ई-निविदा दस्तऐवजांचे सर्व देकारदारांकडून वसूल करावयाचे छाननी शुल्क
०१	रु. ०३ लाखापर्यंत	रु. ३३०/- + १८% वस्तू व सेवाकर
०२	रु. ३,००,००१/- ते रु. ५,००,०००/-	रु. ६६०/- + १८% वस्तू व सेवाकर
०३	रु. ५,००,००१/- ते रु. १०,००,०००/-	रु. १,३२०/- + १८% वस्तू व सेवाकर
०४	रु. १०,००,००१/- ते रु. २५,००,०००/-	रु.३,३००/- + १८% वस्तू व सेवाकर

०५	रु. २५,००,००१/- ते रु. ५०,००,०००/-	रु. ६,६००/- + १८% वस्तु व सेवाकर
०६	रु. ५०,००,००१/- ते रु. १,००,००,०००/-	रु.१३,२००/- + १८% वस्तु व सेवाकर
०७	रु. १,००,००,००१/- ते रु. २५,००,००,०००/-	रु.१६,५००/- + १८% वस्तु व सेवाकर
०८	रु. २५,००,००,००१/- पेक्षा जास्त	रु.२७,५००/- + १८% वस्तु व सेवाकर

महाराष्ट्र शासनाच्या महाटॅंडर पोर्टलवर निविदा अपलोड करतांना संबंधित खात्याने निविदा शुल्क (Tender Fee) अनुज्ञेय वस्तु व सेवाकरासहित नमूद करणे आवश्यक राहिल. तसेच महाराष्ट्र शासनाच्या महाटॅंडर पोर्टलवर निविदा अपलोड झाल्यानंतर SAP कार्यप्रणालीतील ZFI_MT_CLERK या Tcode द्वारे Fund, Fund Centre, Functional Area, Bid No, Tender Fee Amt, CGST, SGST/IGST इ. माहिती सदर Tcode मध्ये अद्ययावत करण्याची जबाबदारी संबंधित खात्याची राहिल.

अनस्टार दरपत्रिका/ निविदा/ दरपत्रिका/ ई-दरपत्रिका/ई-निविदा दस्तऐवजांकरिताचे निविदा शुल्काचे (Tender Fee) सुधारीत दर दि. ०१.१०.२०२४ पासून मागविण्यात येणाऱ्या सर्व अनस्टार दरपत्रिका/निविदा/दरपत्रिका/ ई-दरपत्रिका/ ई-निविदा दस्तऐवजांकरिता दिनांक ३१.०३.२०२५ पर्यंत लागू राहतील.

तरी सर्व खाते प्रमुख/सहाय्यक आयुक्त/रुग्णालय प्रमुख, अधिष्ठाता यांनी त्यांच्या अखत्यारीतील संबंधित कर्मचारीवृंदाना उपरोक्त सुचनेची काटेकोरपणे अंमलबजावणी करण्याचे तसेच दि. ०१.१०.२०२४ पासून मागविण्यात येणाऱ्या अनस्टार दरपत्रिका/ निविदा/ दरपत्रिका/ ई-दरपत्रिका/ई-निविदा दस्तऐवजांकरिता छाननी शुल्क (Scrunity Fee) न आकारता सर्व देकारदारांकडून या परिपत्रकातील सुधारीत दरांनुसार निविदा शुल्क (Tender Fee) अनुज्ञेय वस्तु व सेवाकरासहित महाराष्ट्र शासनाच्या महाटॅंडर पोर्टलद्वारे ऑनलाइन पद्धतीने वसूल करण्याचे निदेश द्यावेत.

सही/-१३.०९.२०२४
श्री.पांडुरंग गोसावी
प्रमुख लेखापाल (पा.पु.म.नि.)

सही/-१३.०९.२०२४
श्री. सुनील जाधव
प्रमुख लेखापाल (वित्त)

सही/-१९.०९.२०२४
श्री. प्रशांत गायकवाड
उप. आयुक्त (वित्त)

सही/-०१.१०.२०२४

श्री. अभिजीत बांगर
अति.आयुक्त (प्रकल्प)

सही/-०३.१०.२०२४

श्री डॉ. श्री. भूषण गगराणी
महापालिका आयुक्त

परिपत्रक

२०२४-२५

क्र.सीए/एफआरजी/०९ दिनांक ०४.१०.२०२४

प्रत(जादाप्रतीसह) यांना माहितीकरिता व पुढील

आवश्यक त्या कार्यवाहीकरिता अग्रेषित.

Pr. Bajwe
०४/१०/२०२४
प्रमुख लेखापाल (वित्त) यांजकरिता

**PROFORMAS:
PROFORMA- I**

The list of similar works as stated in para 'A' of Post qualification during last Seven years-

PROFORMA- I					
Sr. No.	Name of the Project	Name of the employer	Stipulated date of completion	Actual date of completion	Actual Cost of work done
1	2	3	4	5	6

NOTE:

- a. Scanned Attested copies of completion/performance certificates from the Engineer-in-Charge for each work should be annexed in the support of information furnished in the above proforma.
- b. Works shall be grouped financial year-wise.

PROFORMA- II

Yearly Turnover During the Last Three Years.

PROFORMA- II					
Sr.No.	Financial year	Annual Turnover of Civil Engineering Works	Updated Value to Current year	Average of last 3 years	Page No.
1					
2					
3					
Total					

NOTE: The above figures shall tally with the audited balance sheets uploaded by the tenderer duly certified by Chartered Accountant.

PROFORMA- III

At least similar work, as stated in para 'A' of Post qualification,

PROFORMA- III							
Name of the Project	Name of the Employer	Cost of the Project	Date of issue of work Order	Stipulated Date of Completion	Actual Date of Completion	Actual cost of work done	Remarks explaining reasons for delay, if any
1	2	3	4	5	6	7	8

NOTE: Scanned Attested copies of completion/performance certificates from the Engineer-in-charge for each work should be annexed in support of information furnished in the above proforma.

PERSONNEL

PROFORMA- IV					
Sr. No.	Post	Name (Prime Candidate / Alternate)	Qualification	Work Experience	
				No. of years	Name of the Project
1					
2					
3					
4					

NOTE: Scanned Attested copies of qualification certificates and details of work experience shall be submitted /uploaded.

MACHINERY: (for Special Work only)

PROFORMA- V/A			
Sr. No.	Equipment	Number	Owned/Leased/Assured access
1	2	3	4

PROFORMA- V/B

PROFORMA- V/B			
Sr. No.	Equipment	Number	Owned
1	2	3	4

NOTE: The tenderer(s) shall furnish/upload the requisite Scanned Attested documents of ownership/leased of machineries. The undertaking from the suppliers will not be accepted.

PROFORMA - VI / A

Details of Existing Commitments and Ongoing Works

PROFORMA- VI / A							
Description of work	Place	Contract No.& Date	Name & Address of employer	Value of Contract in Rs.	Scheduled Date of completion	Value of work remaining to be completed	Anticipated Date of completion
1	2	3	4	5	6	7	8

NOTE: Scanned Attested copies of completion/performance certificates from the Engineer-in-Charge for each work should be annexed in the support of information furnished in the above proforma.

PROFORMA - VI / B

Details of works for which bids are already uploaded -

PROFORMA - VI / B						
Description of Work	Place	Name & Address of employee	Value of Contract in Rs.	Time Period	Date on which decision is expected	Remarks
1	2	3	4	5	6	7

NOTE: Scanned Attested copies of certificates from the Engineer-in-charge for each work shall be annexed.

PROFORMA- VII

Information on Litigation History in which the applicant is involved.

PROFORMA – VII				
Other Party (/Parties)	Employer	Cause of Dispute	Amount involved	Remarks showing Present Status.
1	2	3	4	5

NOTE: Scanned Attested copies of completion / performance certificates from the Engineer-in-charge for each work should be annexed and uploaded.

SECTION – 16

DRAWINGS

Ashok Nagar, Marwa Rd., Sakinaka. (Dia. 600 mm)

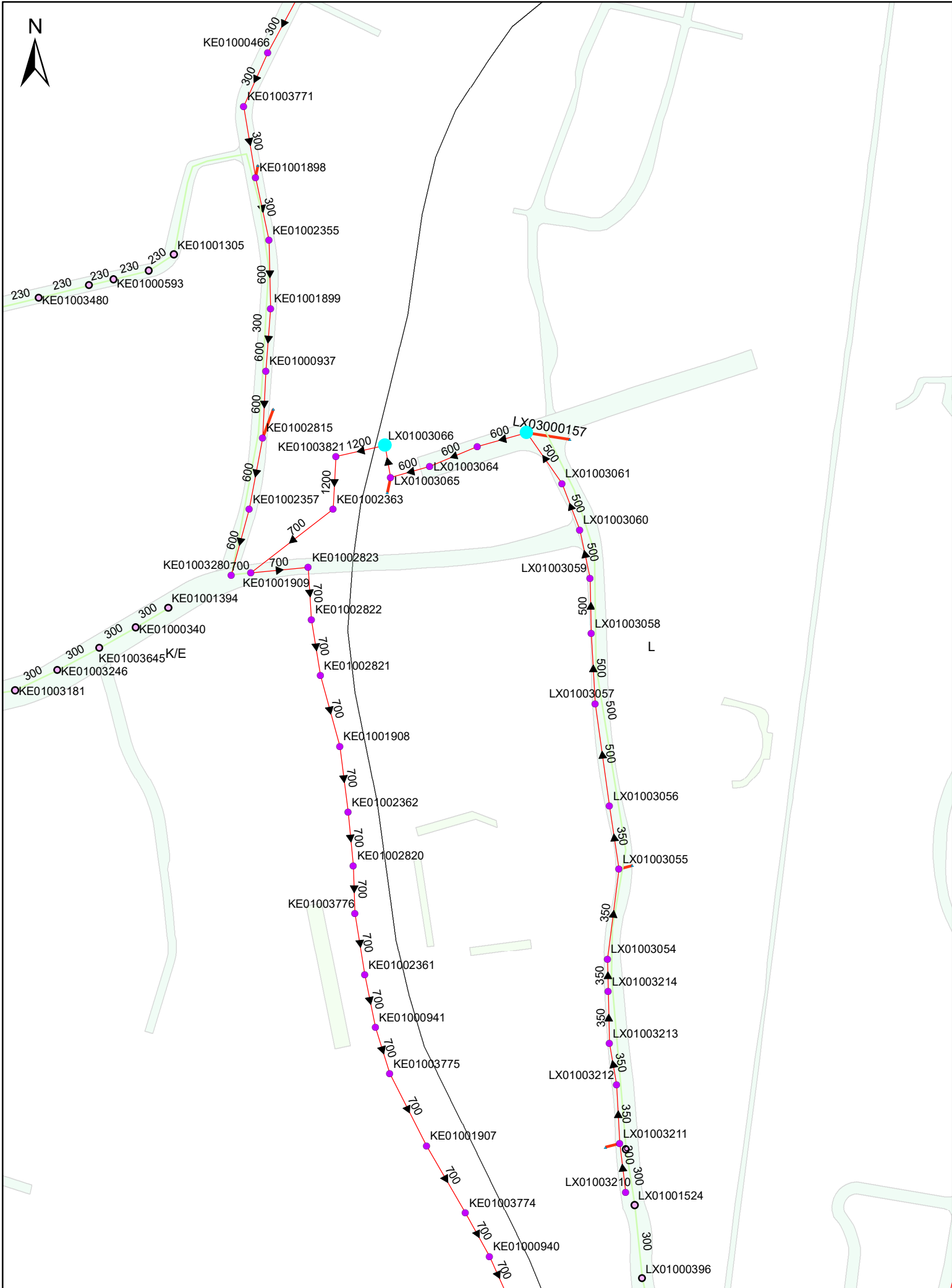

V.N.Purav Marg (Dia 600mm)

